

Savoir sans Frontières
Ny tantaran'i Anselme Lanturlu

KAJIMIRINDRA MAHAGAGA

Jean-Pierre Petit



Nandika teny : Tantely Randriamitantsoa
Lohateny niaingàna : L'informagique

<http://www.savoir-sans-frontieres.com>

INDRO IREO ZAVATRA REHETRA TIANAO HO FANTATRA MOMBA NY INFORMATIKA NEFA TSY SAHINAO NANONTANIANA OLONA MIHITSY

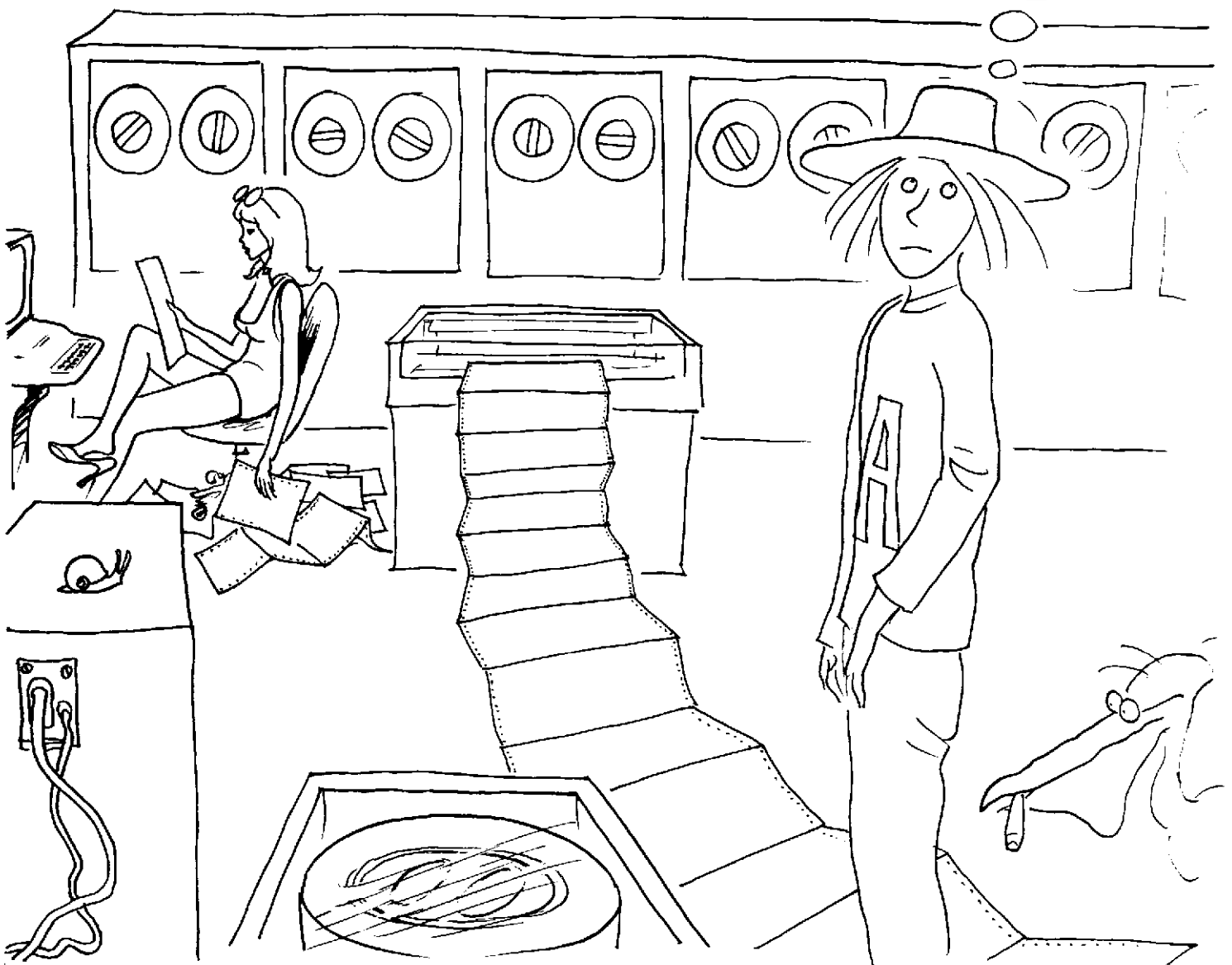

SOFIA A, AIZA NO MISOY
ANTSIKA IZANY ?



MMM...
... IRAY SEGONDRA...
... ATO AMIN'NY TRANO
FANAOVANA KAJY
ISIKA IZAO.

FA INONA IO
KAJY ATAONAO
IO ?

A... IZAO... SAROTRA BE
NY HANAZAVA IZANY
AMINAO... MANAO KAJY
AHO... IZAY FOTSINY

NDAO HOE
HOJERENA AKAIKY
ITY ZAVATRA
ITY...



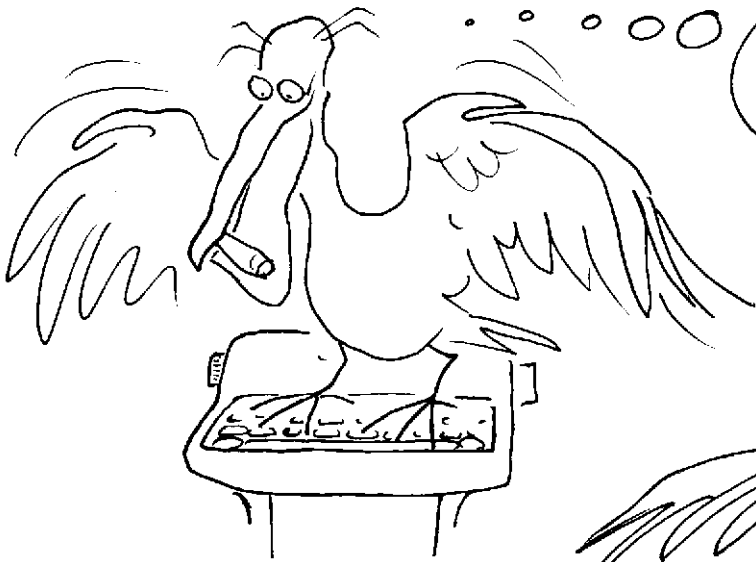

MAHAFINARITRA KOSA IRETO
BOKOTRA MILOKOLOKO IRETO
AN

MBA INONA ARY
NO ILÀNA
AN'IRETO ?

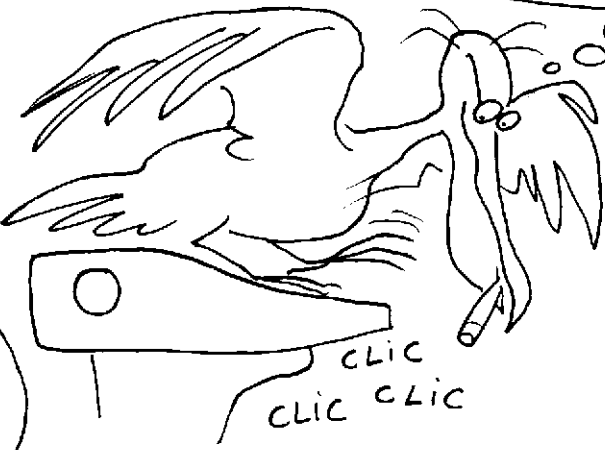

FA... INONA KOA ITY
ZAVATRA TSY MISO
DIKANY ITY !?

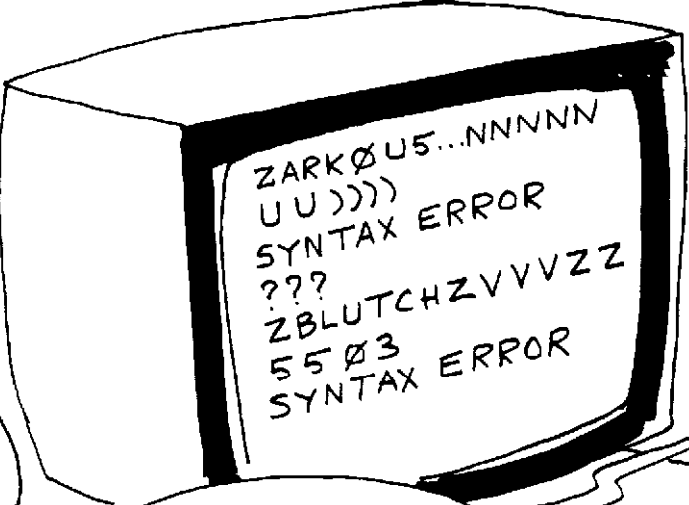

TENA FARANIZAY
TSY AZOKO !

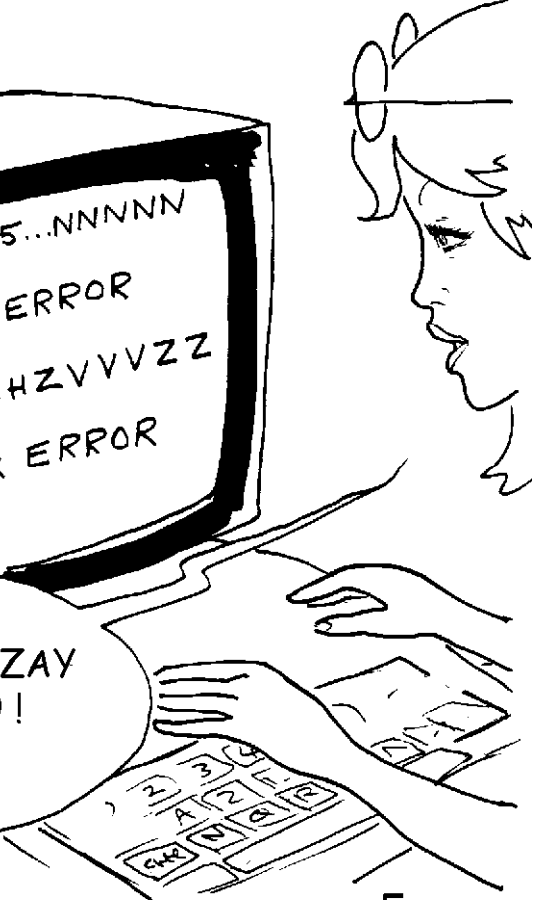

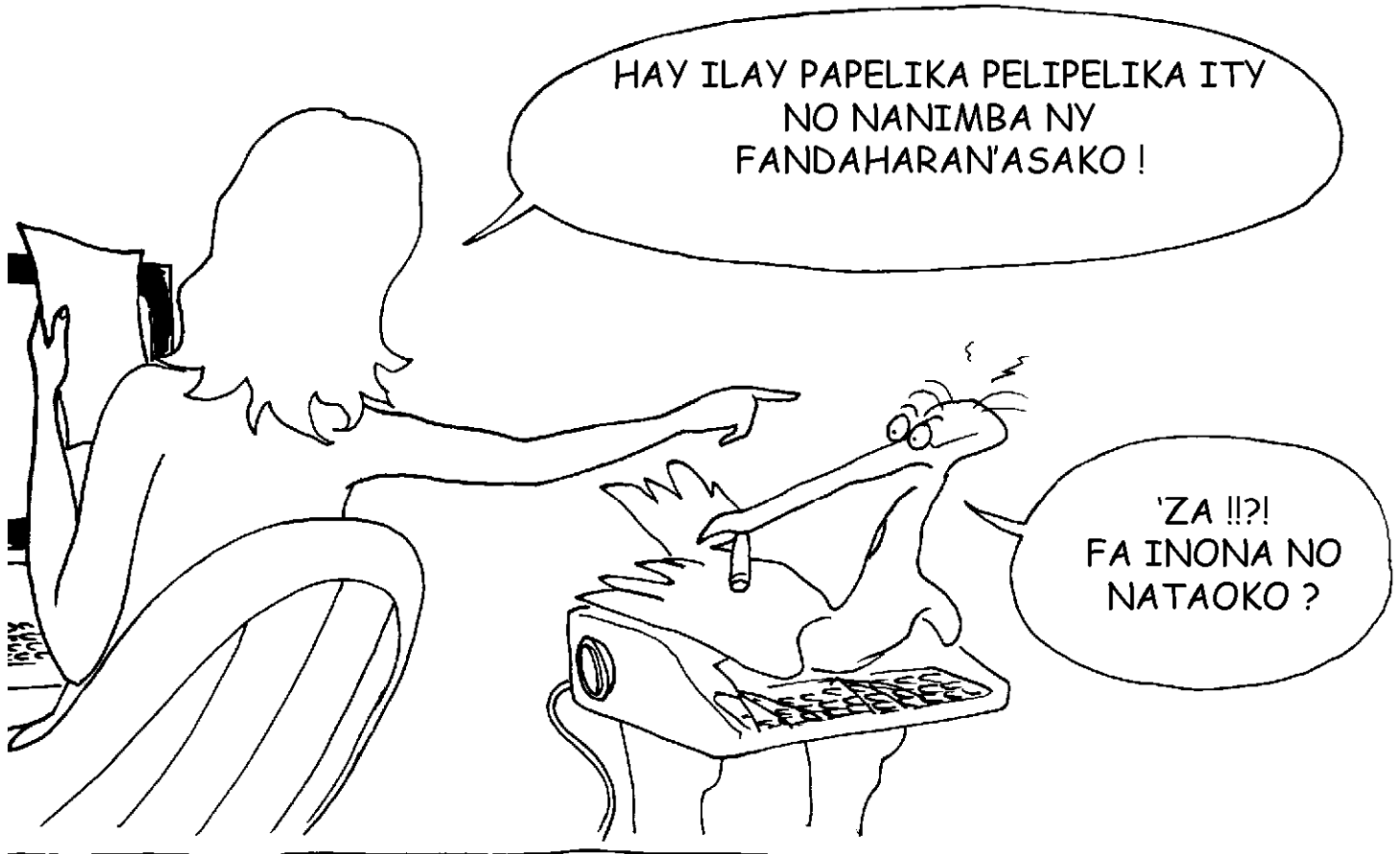

HAY ILAY PAPELIKA PELIPELIKA ITY
NO NANIMBA NY
FANDAHARAN'ASAKO !

'ZA !!?!
FA INONA NO
NATAOKO ?



HENOY ANIE RY MALALAKO ISANY E, MISOY ASA TSY MAINTSY
VITAIKO IZAO. MANDRITR'IZANY FOTOANA IZANY DIA
MANDEHANA MANDEHANDEHA, MIJERIJERY NY ATI-TRANO.
FA HENDRY TSARA AN, AZA MIKITIKITIKA N'INON'INONA, OK ?

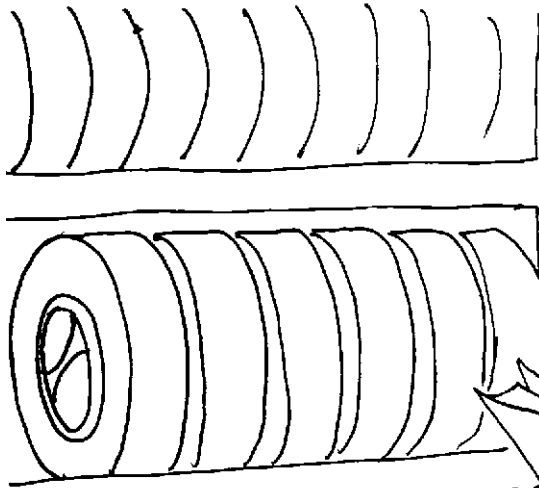

C7 Df



NY SOLOSAINA SY NY FAMPIASANA AZY

ANDRIAKAKY O!
SAROTRA IZY IZANY !...

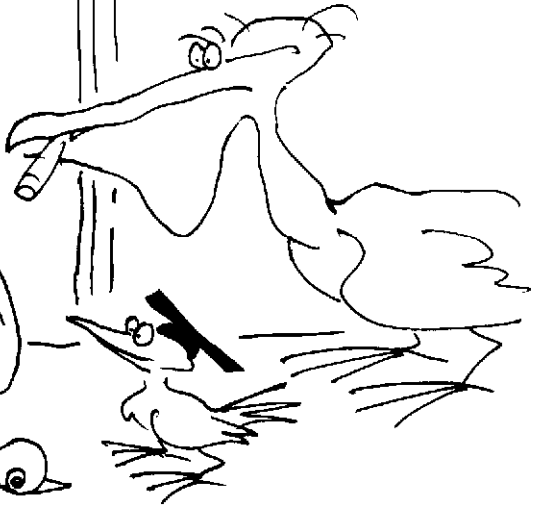

FA REHEFA DINIHINA DIA TOA TSY DIA SAROTRA LOATRA. HENOY : RAHA HILALAO AMIN'NY SOLOSAINA DIA OMENA **BAIKO** FOTSINY IZY



ITO OHATRA ...

... AMIN'NY ALALAN'IRETO KARAZAN-KITENDRY IRETO



NY SOLOS

... RAHA HIDITRA AMIN'NY SOLOSAINA DIA TSINDRIO NY
M A S I N A M A S I N A, DIA AVY EO TSINDRIO NY
BOKOTRA MISO SORATRA HOE **RETURN**

OAY, ARY TSY
HITA TAMPOKA
TEO I SOFIA A.

MAMO-
FOMPOFONA
LOZA IZY
IZANY

TOKONY HIANDRY
AZY HIVERINA IHANY
ALOHA ISIKA !

HOY SOFIA HOE AZA
MIKITIKITIKA
N'INON'INONA !

SOFIA...
ANY ALAVITRA BE ANY
IZY. SADY TSY
VOATERY HITANTARA
NY ZAVA-DREHETRA
ANY AMINY ANIE
ISIKA E !

M.A.S.I.N.A.M.A.S.I.N.A

OAY ! TSY METY
AKORY ILAY
IZY...

HAY MOA... TSY MANATAN-
TERAKA **BAIKO** NY SOLO-
SAINA RAHA TSY
TSINDRIANA NY BOKOTRA
RETURN.

... BOKOTRA
RETURN... AIZA
ARY IZANY ?...
HAY, ITO !

SSSAF !

ORINA
MANGA
UTILITARA



FA !!..
HAY TENA
MARINA ILAY
IZY

TS'ISY AN'ZANY R'ILAY
DONENDRINA ITY A.
VERY ISIKA !

(*)

(*) ALEO NY MPAMAKY NO HAMINAVINA
NY BANGA ETO

NB : NY MODELIN-TSOLOSAINA SASANY IHANY NO
MISY NY BAIKO MASINAMASINA. RAHA MISALASALA
IANAO DIA AZA MANANDRANA

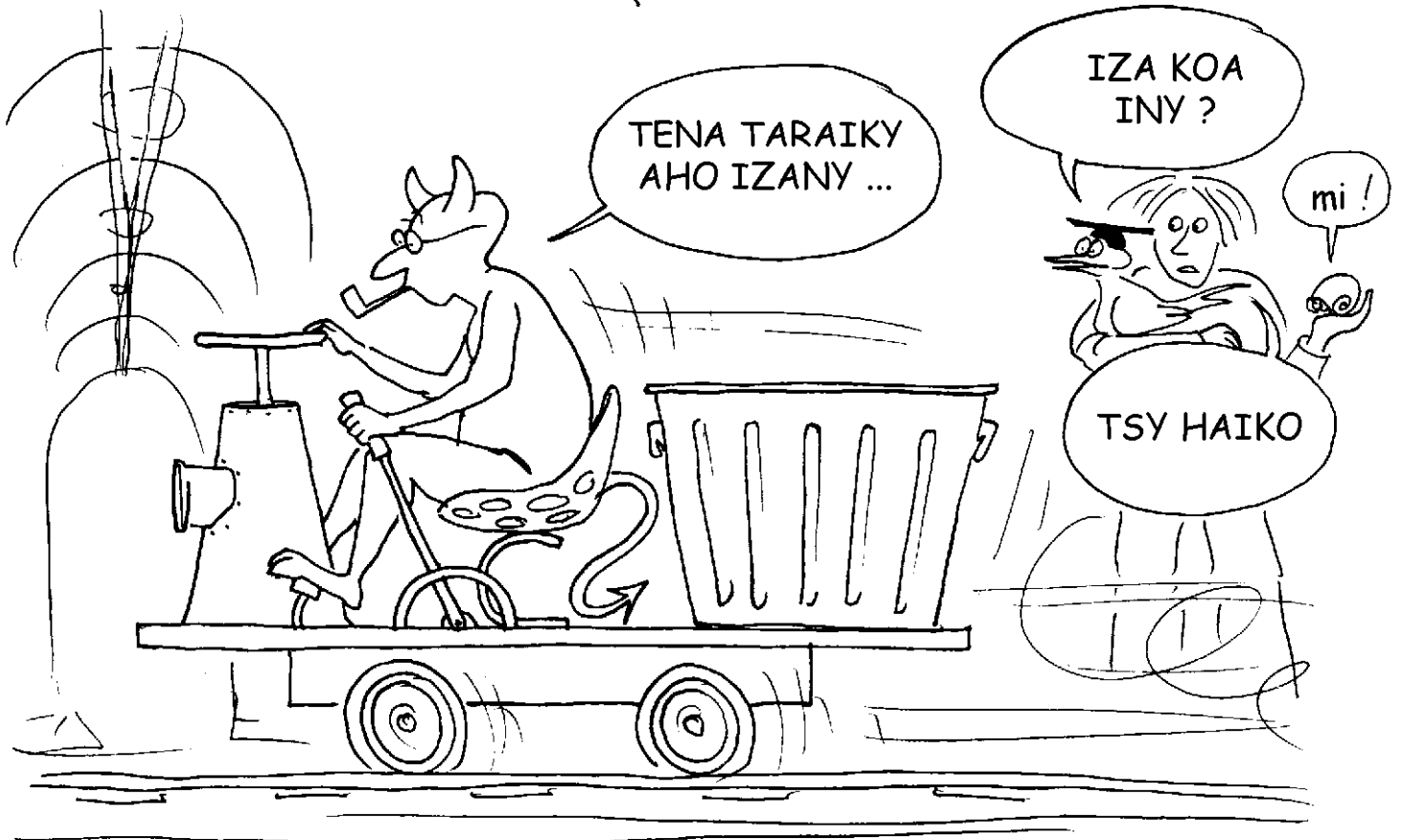
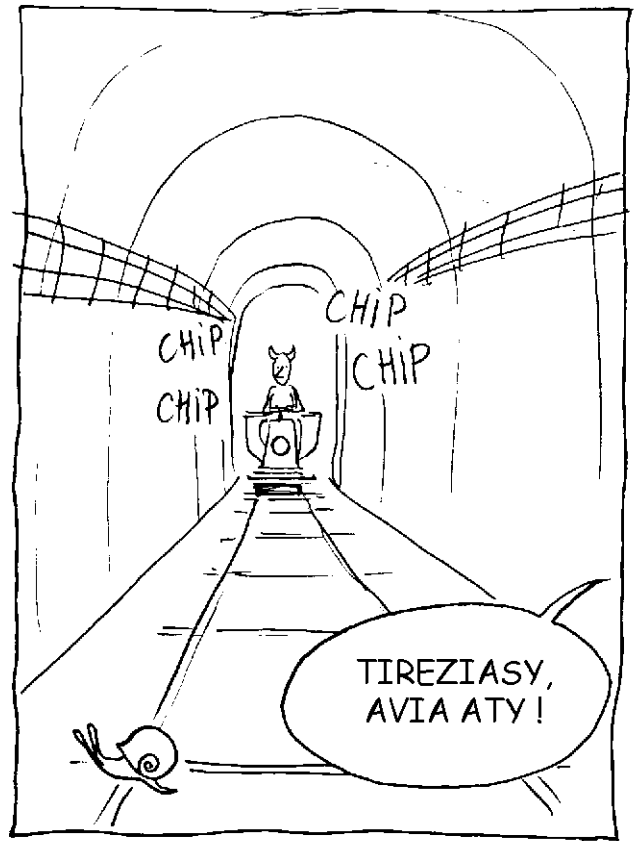
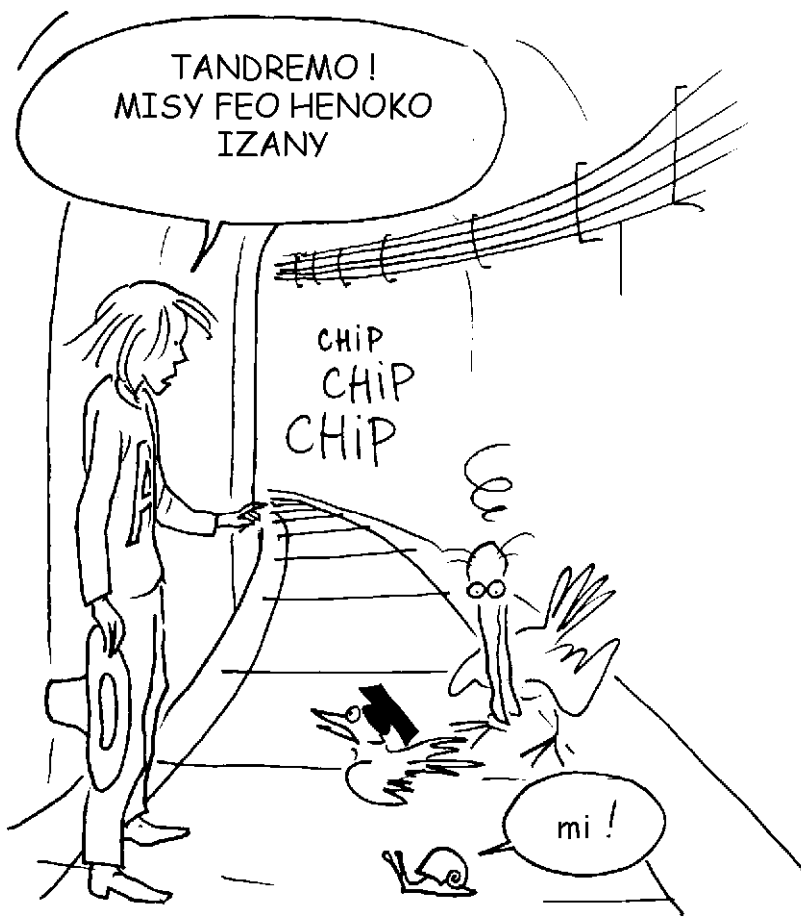

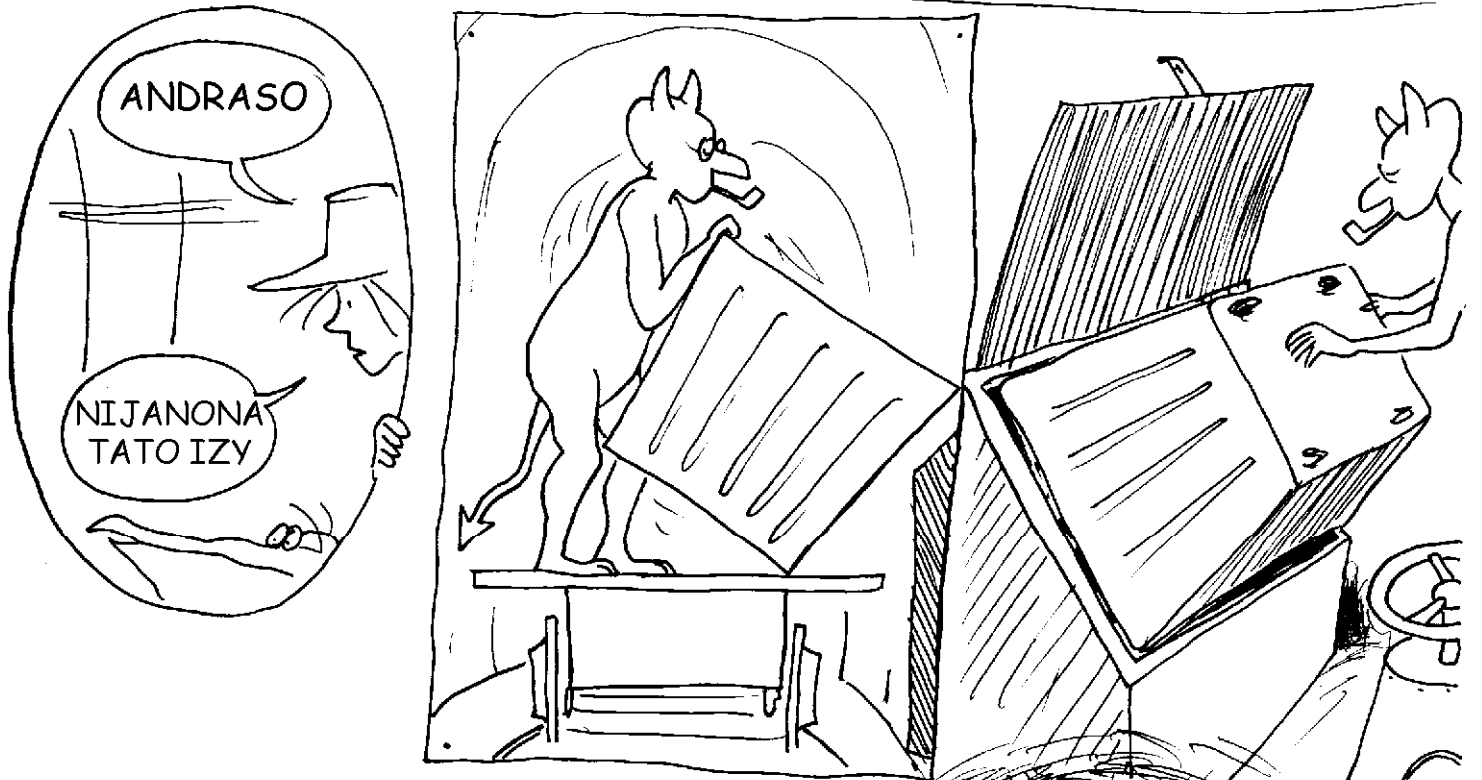

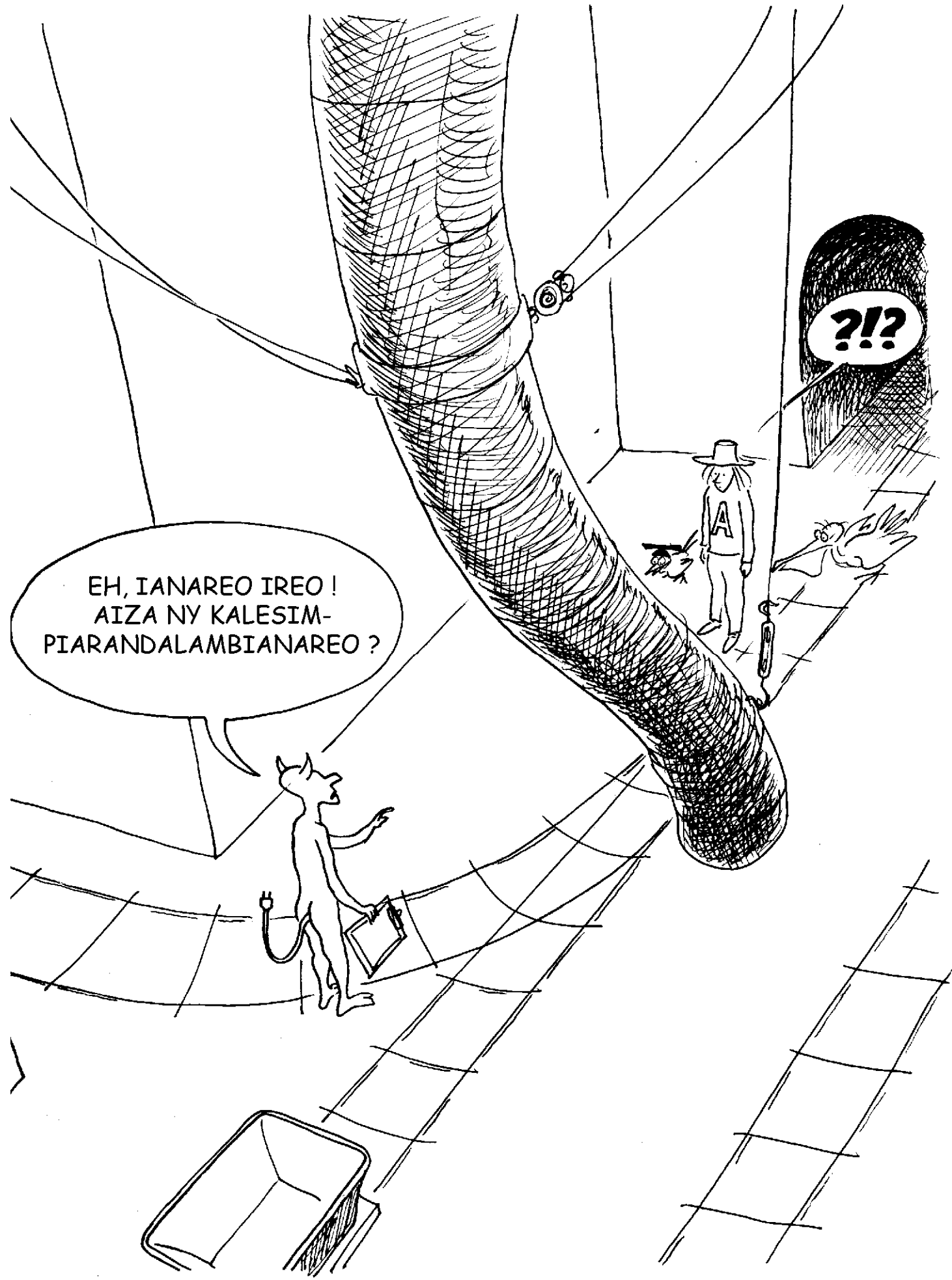

EH, IANAREO IREO !
AIZA NY KALESIM-
PIARANDALAMBIANAREO ?

?!?

TSY HITAKO ATO ANATIN'NY
FANDAHARAN'ASAKO IANAREO.
TENA MIKORONTANA MIHITSY
ATO IZANY ANDROANY AN



AVY ANY
IVELANY
IZAHAY

IE, DIA TSY HAIKO RAHA
AFAKA MANORO NY LALANA
HIVOAHANAY TATO
IANAO...

EFA MIVOATRA BE KOA IZAO
TONTOLO IZAO KA TSORIKO
FA MILA HO VERY MIHITSY
AZA AHO INDRAINDRAY



VERY TAHAKA
ANAY IZAO VE ?

IVELANY ?
ANTOKOM-PIASA
VAOVAO ANGAMBA
IZANY



AO FA MANDRAY
ANAREO AHO REHEFA AVY
EO. MBOLA MISY
ENTREE TOKONY
HOKARAKARAINA ITO



DRRRRIING



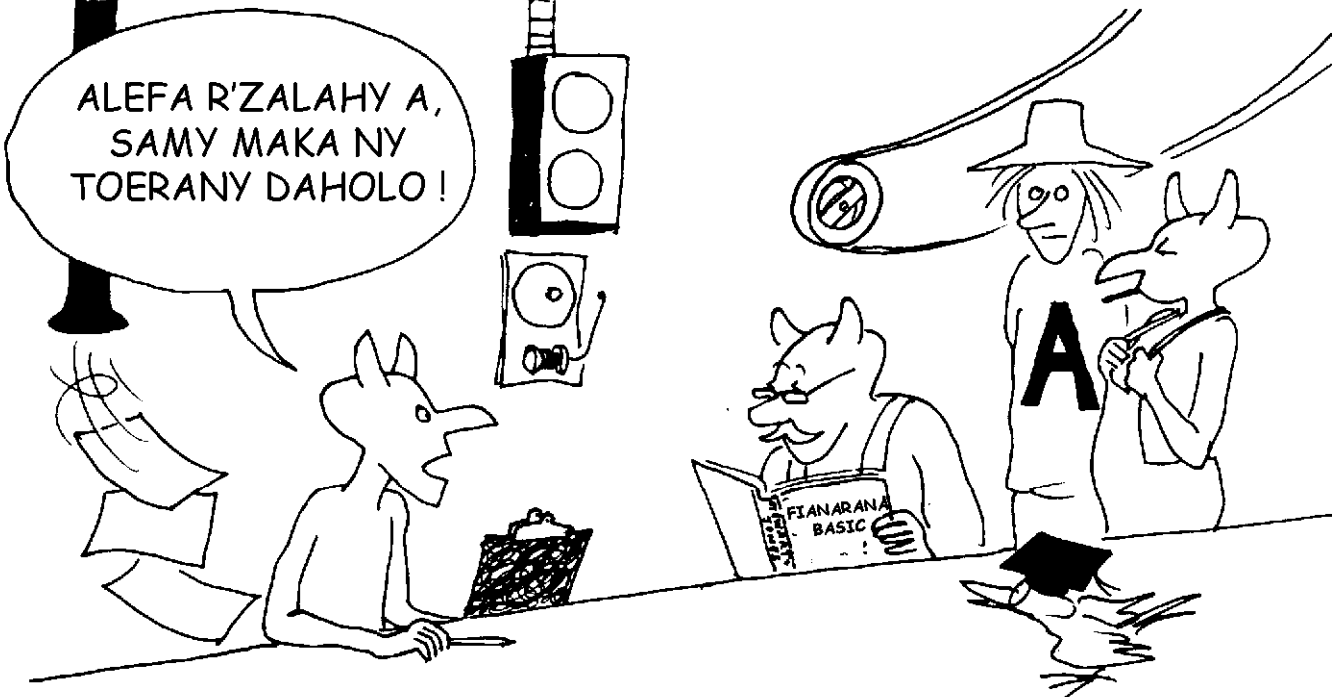

MAXIE A, ITADIAVO TOERANA MALALAKA AHO!

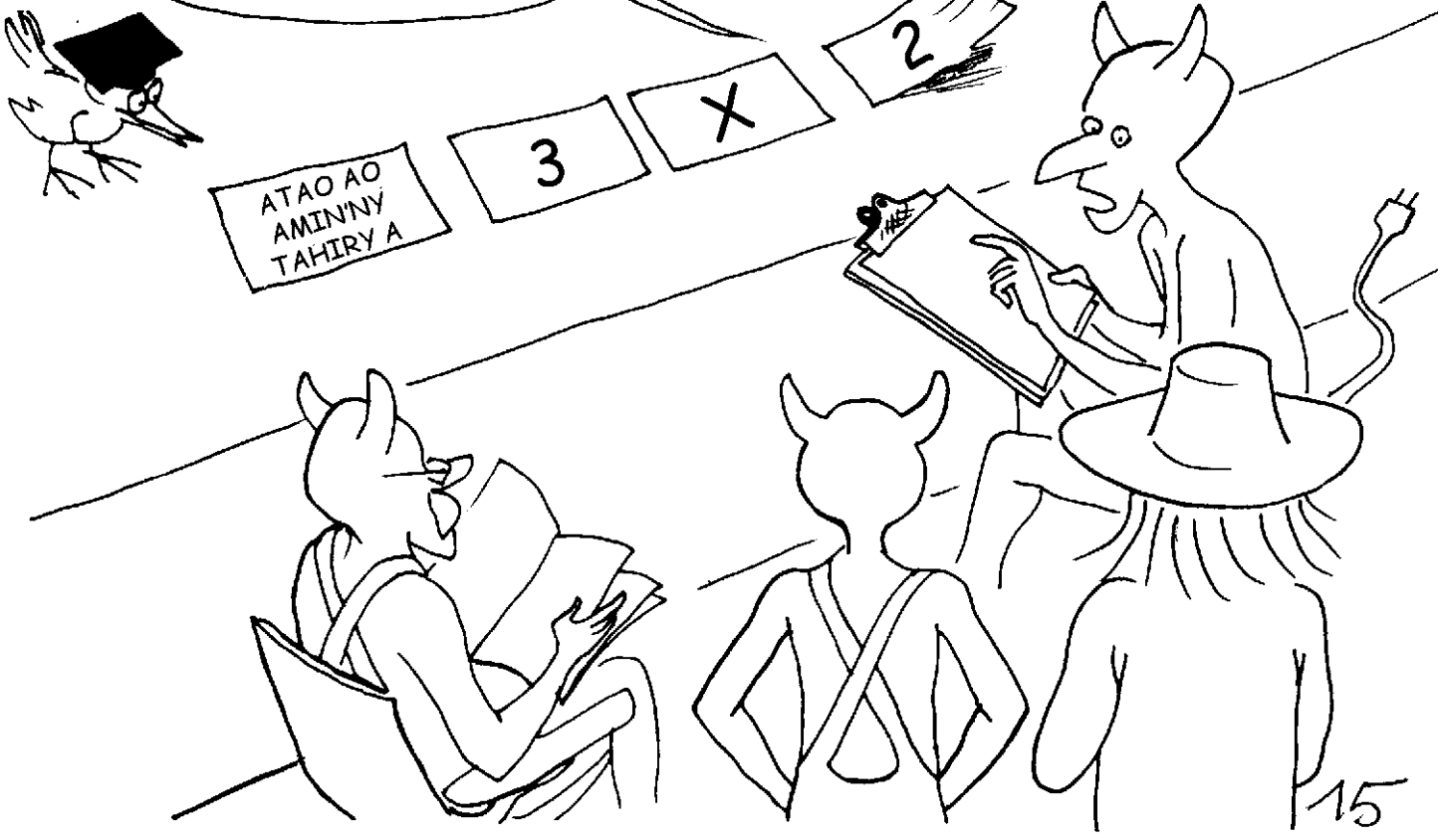

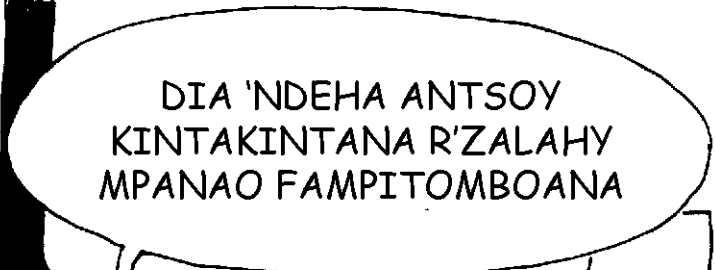

VONONA VE I
LEON ?
ALEFASO ARY
NY **BUS** !

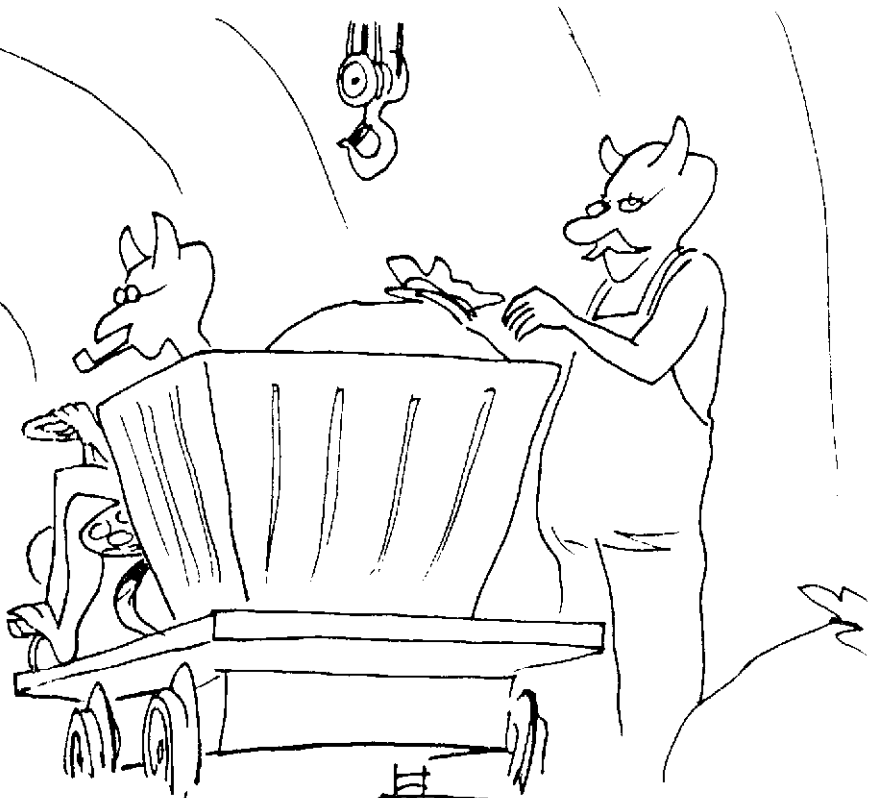

DIA
AHOANA ?

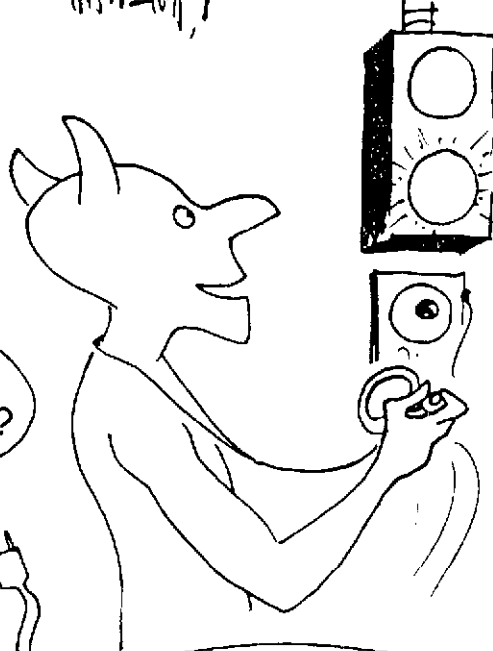

IZAY FA
VITA

KLIK



EFATRA
MIKROSEGONDRA ?
TSY RATSY KOSA
KOH !

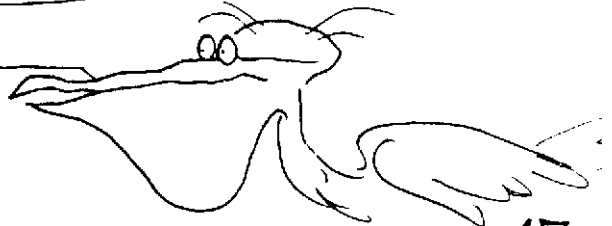



FA TOKONY MBOLA
HAHAVITA TSARATSARA
KOKOA NOHO IZANY
ISIKA!

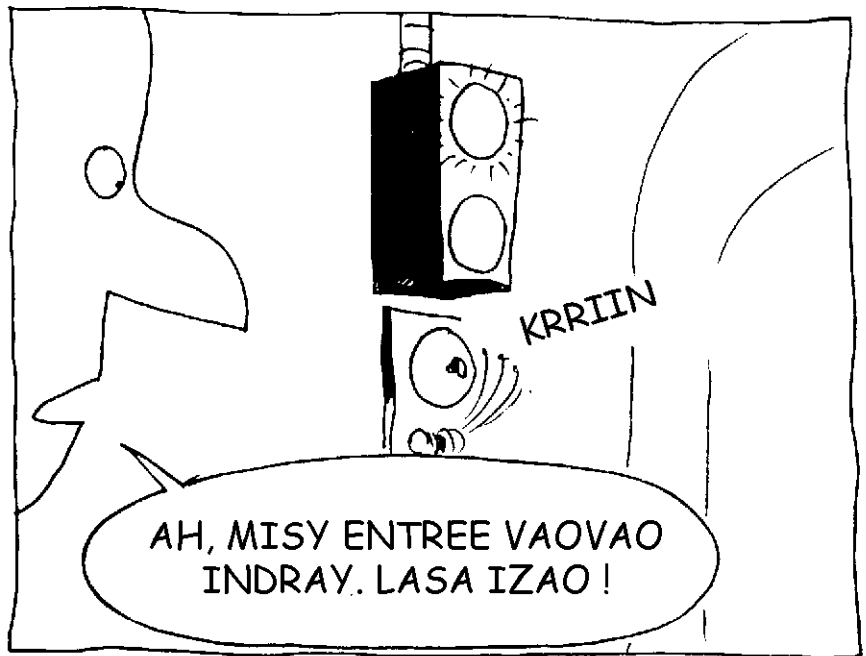

AH, MISY ENTREE VAOVAO
INDRAY. LASA IZAO!



SAMY MAKA NY
TOERANY
INDRAY E



ITONY VE NO
ATAO HOE
ENTREE ?



4

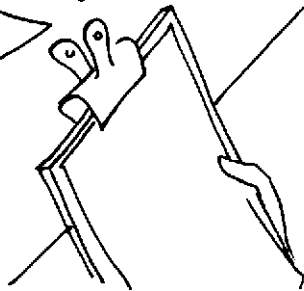

MAXIE, JOEY ?



INDRETO
IZAHAY
TOMPOKO!

LEON, FA LASA AIZA
I LEON !?! ...
MITSOAK'ADY
INDRAY NY SASANY !



ARY INONA KOA ITY MIRA-
VIRAVY TANANA ITY E?
ALEFASO FA MISOY KAJY
TOKONY HATAO AO !

'ZA VE ?

IE, **IANAO** !
HITA MIHITSY HOE MBOLA
MPIASA VAOVAO IANAO ITY
KAH !

ALEFA E, ALEFA E !
MANDEHA IHANY NY
MIKROSEGONDRA

ALEOKO
MODY

AIZA MOA IZAO
NY "PREMIERE" ?

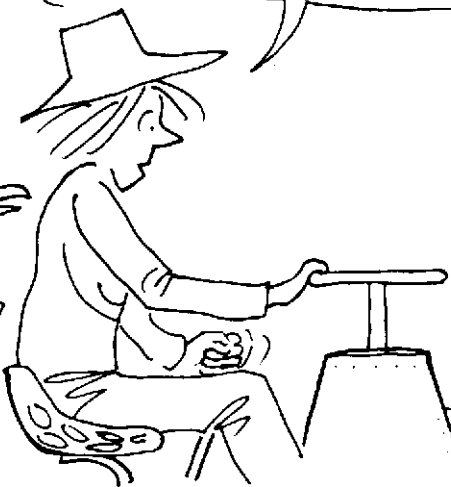
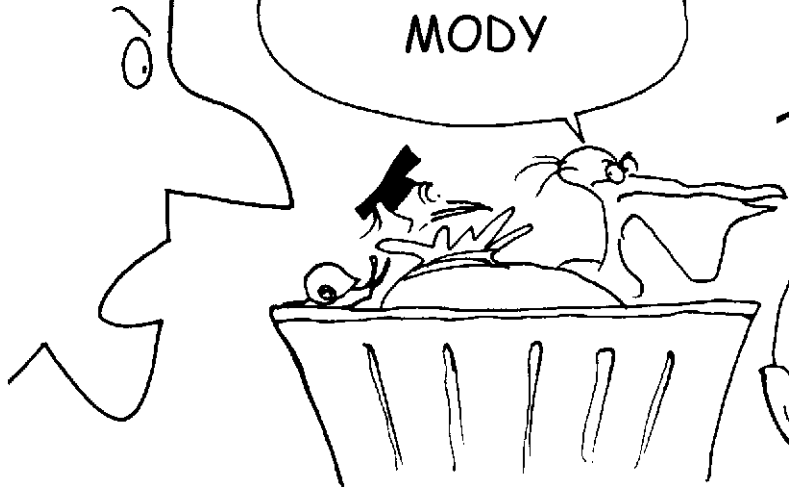

ANDRIAKAKY O,
MANDEHA MAFY
IZY IZANY !!!

... FANAOVANA TORA-
DROA... FIZARANA... TSY
IZY IZANY !

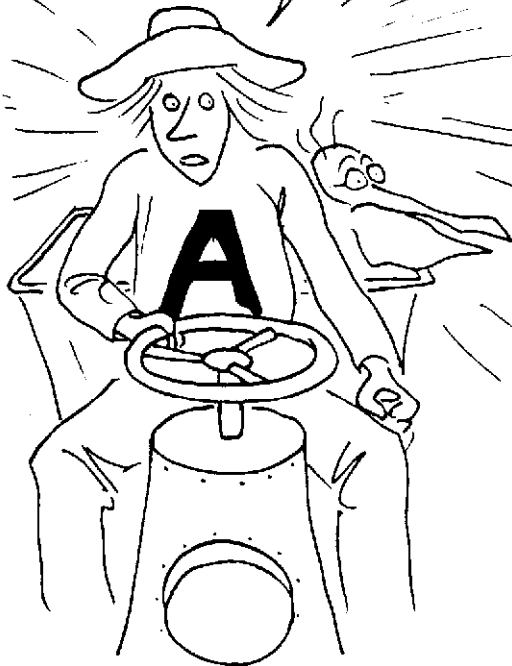

EH!?

TOA ATO
ANGAMBA IZANY
FANAMBARANA
IZANY...



TENA TSY MIFIDY
OLONA HORAISINA
MIASA INTSONY
RY ZALAHY A. SA
AHOANA RY **BUG** ?

IEOA !

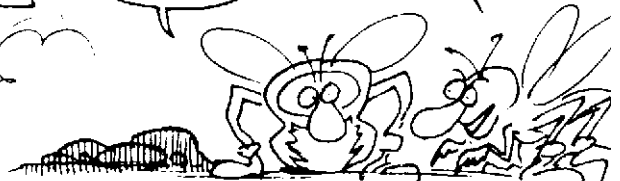

A...SAIKA MBA HANAO
FANAMBARANA
AZAFADY...

FANAMBARANA ?

'ZAH TSY MANAO
FANAMBARANA

FA...

ANTOKOM-PIASA
Hafa no manao
an'izany

FANOVA-MARIKA

4

OAY!

21



AH, ATO KAY ILAY
IZY

FANAMBARANA

LEITY E, KAY
GAULOISE ILAY
IZY

A... MBÔLA TSARA...
TOKONY HANAMPIANA NY
RAKITRY NY
TAHIRIN'NY A ITY
ZAVATRA ITY

ENY E, VONONA NY HANAO
IZANY AHO FA TSY HITAKO
IZAY RAKITRY NY TAHIRY A
EO.

IZAHO ANIE...
A...

METY HADINONAO
ANY AMIN'NY **TAHIRY**
FOIBE ANGAMBA
ILAY IZY

TAHIRY FOIBE

AH, TONGA ISIKA

SALAMA, SAIKA MBA HAKA NY RAKITRY NY TAHIRY A AHO

DIKAN'NY TAHIRY NO AZOKO OMENA ANAO

TSY MANAN-JO HANOME TAHIRY AHO FA DIKA KAMBANA AMINY IHANY

ITO





MISY MARI-TSORATRA FAMANTARANA
NY **EFI-TAHIRY** SASANY FA NY
SASANY KOSA TSY MISY.
FA MANINONA ?

EFITRA **MBOLA TSY**
NAMPIASAINA
IREO

IZANY HOE ?

IZANY HOE TSY MISY
N'INON'INONA AO ANATINY DIA
NOHO IZANY DIA TSY AMETAHANA
N'INON'INONA ETY IVELANY,
MAZAVA HO AZY !

HITA MIHITSY IANAO HOE
MBOLA MANAVAO

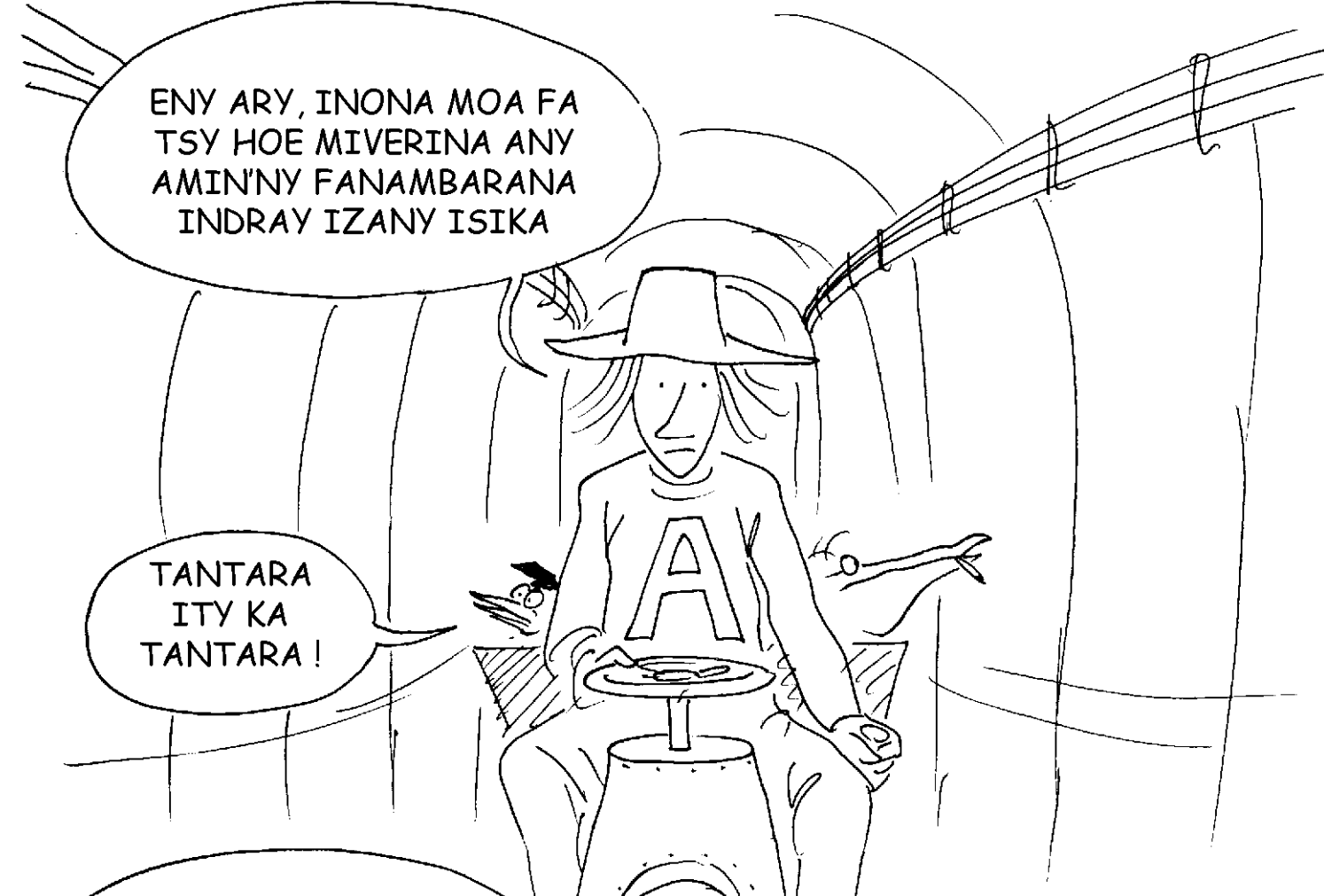

ENY ARY, INONA MOA FA
TSY HOE MIVERINA ANY
AMIN'NY FANAMBARANA
INDRAY IZANY ISIKA

TANTARA
ITY KA
TANTARA !

MANINONA RAHA
JERENA NY AO
ANATIN'IRETO KITAPO
IRETO ?



OAY E !!!

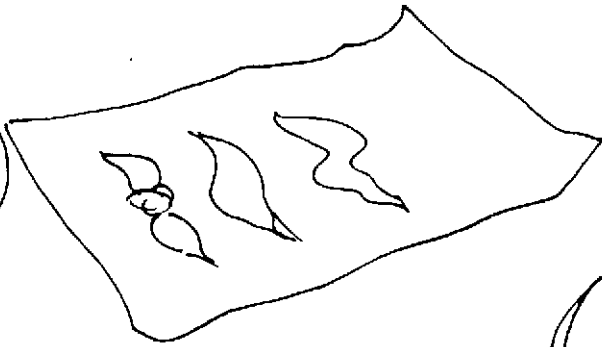
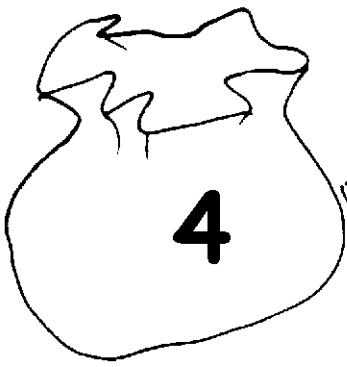

TOY IZAO NY FILAHARAN-JAVATRA TAO AMIN'NY KITAPO "4" :
MOSOARA MIFATOTRA IRAY ARY MOSOARA TSY MIFATOTRA ROA

NY KITAPO "A" KOSA DIA NISY
FILAHARAN-JAVATRA TOY IZAO :
MOSOARA MIFATOTRA ROA ARY
MOSOARA TSY MIFATOTRA IRAY



INONA NO ILÀNY
AN'IREO MOSOARA
REHETRA IREO ?



FANORA-MIAFINA ROA
FOTOTRA IO. HITAKO NY
FOMBA NANAOVANY AZY TEO.

AOTRA NO DIKAN'ILAY
MOSOARA TSY MIFATOTRA
ARY **IRAY** NO DIKAN'ILAY
MOSOARA MIFATOTRA

DIA
MANINONA ?



TSOTRA E : REHEFA MANISA IANAO DIA MANORATRA HOE IRAY=1,
ROA=2, TELO=3, EFATRA=4, DIMY=5, ENINA=6, FITO=7, VALO=8,
SIVY=9. DIA AVY EO REHEFA HANORATRA NY FOLO DIA ASIANAO 1
SY 0. DIA HO AN'NY IRAIKA AMBIN'NY FOLO, ASIANAO 1 SY 1, ROA
AMBIN'NY FOLO 12, sns...

IZANY NO ATAONAO SATRIA
FAMANTARANA FOLO NO
NAMPIASAINAO HANORATANA IREO ISA IREO
1, 2, 3, 4, 5, 6, 7, 8, 9, 0

 = \emptyset = AOTRA

 = 1 = IRAY

IZAO INDRAY DIA
ERITRERETO HOE
FAMANTARANA ROA NO
ANANANAO FA TSY **FOLO** ARY
IREO FAMANTARANA IREO DIA
 \emptyset NA 1 (*). TEO IANAO DIA

NAMPIASA **FANISA**
AMPOLONY FA
IZAO INDRAY DIA
FANISA ROA FOTOTRA

DIA TSY HAIKO
INTSONY NY
TOHINY AVY EO !

(*) NY SOLOSAINA NO MANORATRA NY
AOTRA HOE \emptyset

AIZA KOSA E ! REHEFA TONGA
EO AMIN'NY ROA IANAO DIA
MANORATRA HOE 1Ø

NOHO IZANY NY TELO
DIA 11. DIA INONA
INDRAY NO ATAOKO
AVY EO ?!?

OADRAY MARINA...
OHATRA NY AZOKO
IZY IZANY...

DIA
TOHIZO E

NOHO IZANY DIA NY
ISA ENINA NO TAO
ANATIN'NY KITAPO A,
IZANY HOE NY VALIN'NY
KAJY TEO ALOHA TEO :
2x3

IZAHO MIHEVI-
TRA HOE MISY
FIKA IO...

=Ø=AOTRA

=1=IRAY

=2=ROA

=3=TELO

=4=EFATRA

=5=DIMY

=6=ENINA

=7=FITO

=8=VALO

FA... MANINONA RAHA
TAZONINA NY FANISA
AMPOLONY ?

SATRIA RY ZAREO AO ANATY
SOLOSAINA AO DIA TSY
MAHAY AFA-TSY NY KAJY
ROA FOTOTRA

FANAMBARANA

EH, AJANONY NY BUS.
TAFEVERINA ETO
AMIN'NY FANAMBARANA
ISIKA.

ENY ARY, ENY ARY...
 $110 + 100 = ?$

TOY IZAO IREO KAJY FOTOTRA
TSOTSOTRA :

$$0+0=0$$

$$0+1=1+0=1$$

$$\text{ARY } 1+1=10$$

(IZANY HOE ATAO
AN-KANDRINA NY 1)

SATANA
O...

AOTRA SY AOTRA : AOTRA
AOTRA SY IRAY : IRAY
IRAY SY IRAY : SORATAKO
NY AOTRA DIA ATAOKO
AN-KANDRINA NY IRAY.
DIA AVY EO APETRAKO NY
IRAY

$$\begin{array}{r} 100 \\ + \\ 110 \\ \hline 1010 \end{array}$$

REHEFA TOHIZINA ILAY
FAFANA AO AMIN'NY PEJY 28
DIA MANOME **FOLO**

MISY FIKA
IO, TSY
MAINTSY !

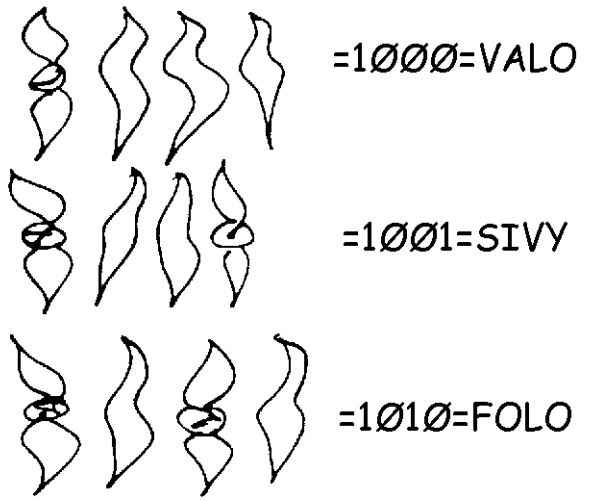

TIREZIASY A, TENA
FARAN'IZAY TSOTRA IZANY
ZAVATRA IZANY. MIFANTOHA
KELY AMIN'IZAY HOLAZAIKO
FOTSINY IANAO...

mi !

OH, IZAHO ANIE TSY DIA
MIRAIKA AMIN'IZAY VALIN'IO
E. SAMY MANANA NY ASANY
IO. IZAHO MANANGONA AZY
AO AMIN'NY TAHIRY FOTSINY
SY MANOME DIKANY MITOVY
AMINY

TIREZIASY,
DONENDRINA BE
IANAO

DIA ASIANA **FOLO**
AO AMIN'NY
TAHIRY **A** !

ALEO AHO
HIVOAKA TATO
R'IRETO A !

FA INONA NO NATAONAREO NANDRITR'IZAY FOTOANA IZAY?!?
LASA VOATOHINTOHINA DAHOLO ILAY KAJY TOHI-VAKANA
NOHO IANAREO.

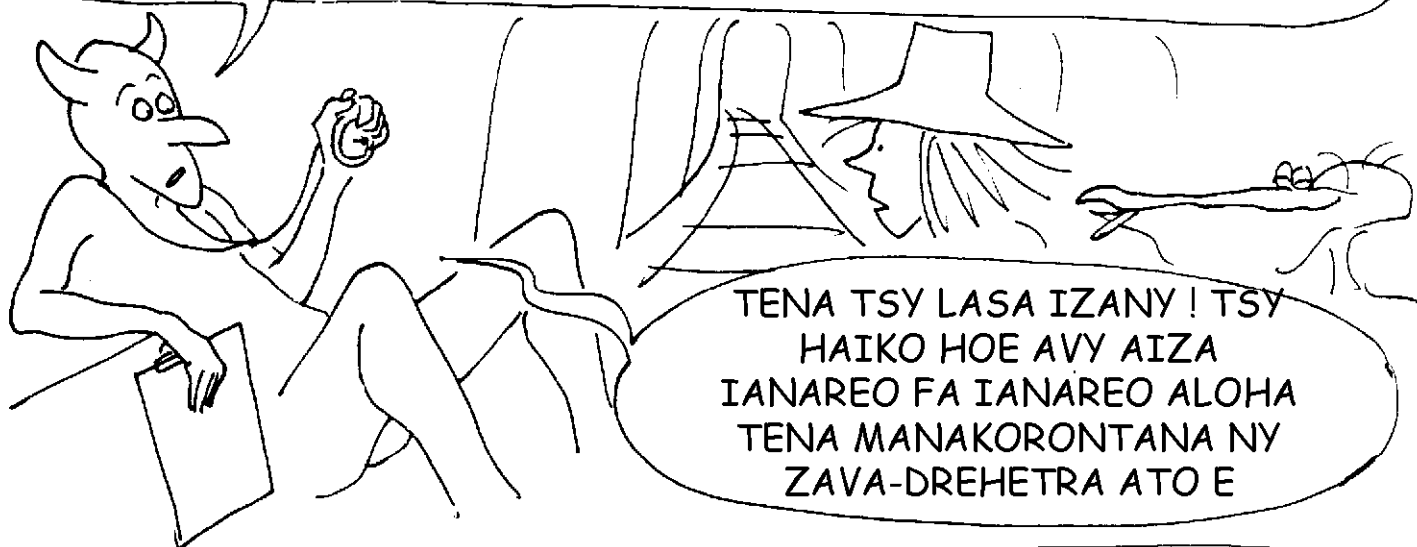

TENA TSY LASA IZANY ! TSY
HAIKO HOE AVY AIZA
IANAREO FA IANAREO ALOHA
TENA MANAKORONTANA NY
ZAVA-DREHETRA ATO E



TSY NIVERINA I ANSELME.
MANDRA-PIANDRY AZY DIA HANAMBOATRA
FANDAHARAN'ASA KELY ALOHA AHO. NDEHA
ARY HATOMBOKA AMIN'NY FAMPIDIRANA
SORATRA FOTOTRA

BLOTSSH



!!!

OAY LEITY E, IZAY
INDRAY FA NIVERINA !
NEFA IZAHO TSY
MANANA MPIASA ETO
AKAIKIKO ETO

FA INONA INDRAY
HONO NO
KETREHIN'ILAY
ZAVAVY INY E ?

OK, MIVERENA ANY AMIN'NY TAHIRY FOIBE.
HANDRAKITRA KARAZAN-TSORATRA
FOTOTRA ROA IANAREO. NY SINGA TSIRAIRAY
AO AMIN'IREO KARAZANA IREO DIA VONDRONA
LITERA, IZANY HOE TENY

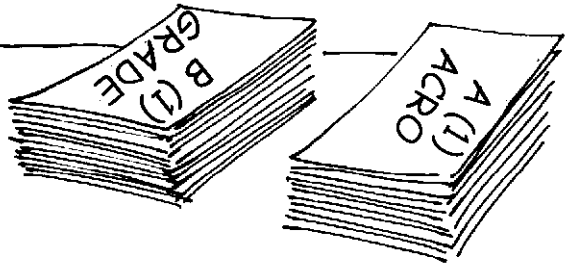

AFAKA TEHIRIZINA IZANY
NY TENY ?

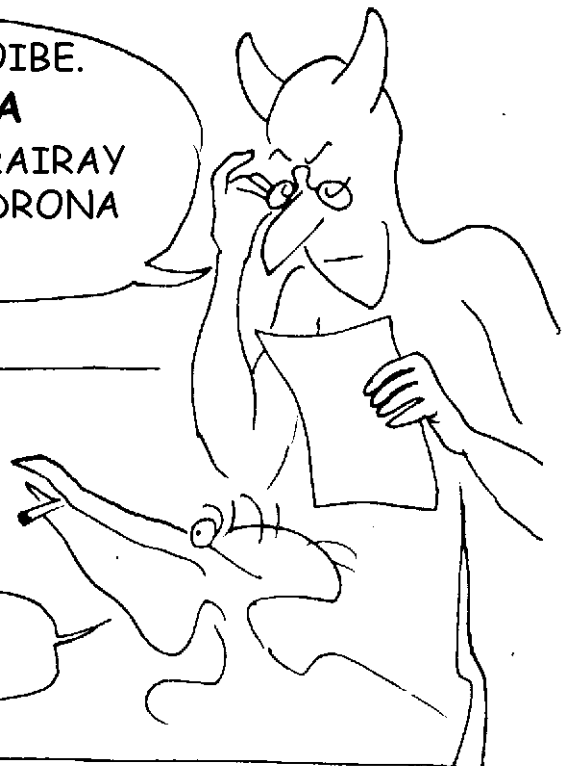

MAZAVA HO AZY FA AZO ATAO NY MITAHIRY TENY ! AMPIFANDRAISINA
AMIN'NY SORA-MIAFINA MANARAKA FANISA AMPOLONY ALOHA IZY, DIA
AVY EO IO ISA IO ADIKA HO FANISA ROA FOTOTRA

FONOSANA ROA SAMY MISY TENY TELONJATO IREO
SORATRA FOTOTRA IREO. IREO VOALOHANY DIA
HATAO HOE A(1), A(2), A(3), ... , A(300) ARY IREO
FAHAROA B (1), B(2), B(3), ... , B(300)

AH, ARY SATTRIA IANAREO EFA ANY IHANY
DIA **AMANDRIHO** TELONJATO EFI-TAHIRY
ROA AHO

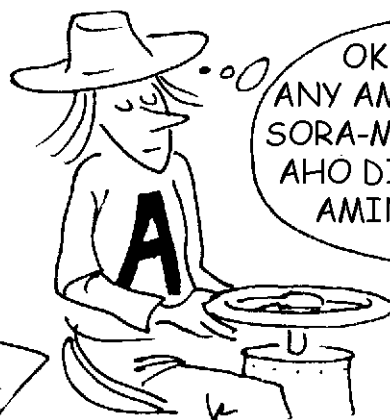
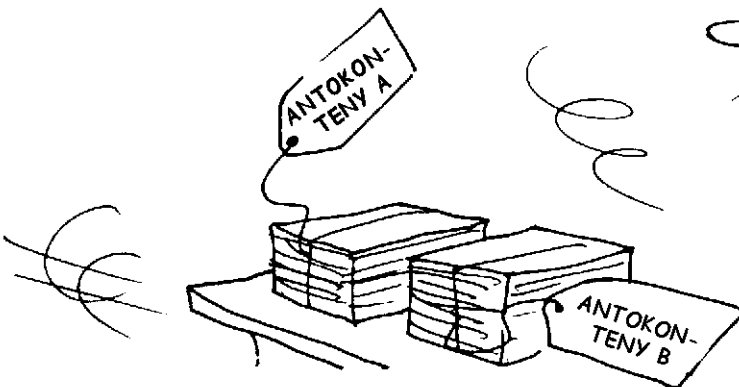

OK, MANDALO
ANY AMIN'NY MPANAO
SORA-MIAFINA ALOHA
AHO DIA AVY EO ANY
AMIN'NY TAHIRY
FOIBE

TSY FOTOANA
FAMAKIANA
TARATASY IZAO E!

CODAGE



mane, mance, morphe, FA
INONA ARY NO
KETREHIN'ILAY ZAVAVY INY?

ITO RAISO NY
ANTOKO B, IZAHO
HAKA NY ANTOKO A
MBA HANAFANGANA
NY RAHARHA

OK

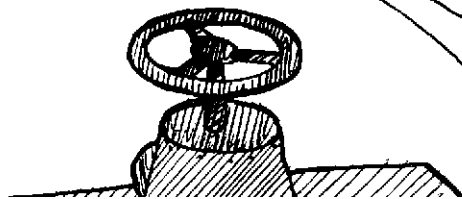
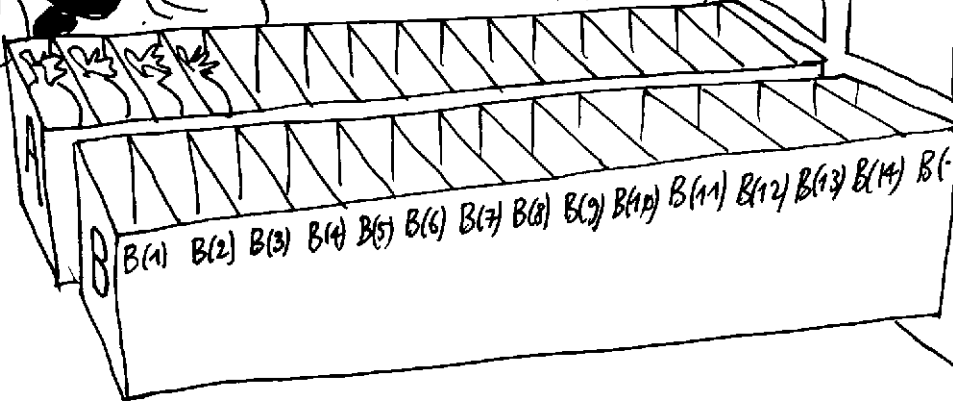

FAMPIASANA
MIVANTANA

FA INONA INDRAV
ARY NO ATAONILAY
MPIASA VAOVAO
INY ?

SKRRR

TAHIRY
FANDAHARANA

KLONK !

OADRAY
MARINA, TENA
FANDAHARANA
ILAY IZY !

1 OMENA
ISA 1 NY
"N"

1 OMENA
ISA 1 NY
"N"

ITO NY BAIKO
VOALOHAN'ILAY
FANDAHARANA

AZZZZA
MAIKA E!

INONA IO
ATAONAREO IO ?

A

MANDAMINA NY LISITRY NY BAIKON'ILAY
FANDAHARANA VAO TONGA AHO.
FANTATRAO IHANY MANTSY FA TSY
VOATERY HILAHATRA IZY RAHA VAO
TONGA INY !

IZANY HOE MANAO NY
FITANISÀ'ILAY
FANDAHARANA IZY

IZAY FA VITA !

MBOLA
MISY IHANY
VE !

TENA MANDRERAKA
MIHITSY IZY AO AMBONY
AO IZANY

AVERINA
INDRAY IZANY
NY FANDAMI-
NANA !

FOANANA NY BAIKO 8
(DISO KELY AHO)
SOLOINA 8 IZY AMPIANA
IRAY NY N

LEITY E, IZAY
INDRAY FA NISY
DISO ILAY IZY!

RAHA MBA FANTATRAREO MOA FA TENA
MAHATROTRAKA ANAY MPIASA MAJINIKA
MIHITSY ANIE IRENY **FANITSIANA NY**
FANDAHARANA IRENY E



FA MBA INONA ARY NO ATAONDRIY ZAREO IRENY !

SAO DIA HIHINANA VATOMAMY IANAO ?

ENY ARY... ALEO TOHIZAKO ITY...



AOK'IZAO FA M'SAOTRA

MBA HAZAVAO AMIKO HOE IZAO ZAVATRA ATOKONAREO IZAO.

IE, TAHAKA NY SAKAFO ATOKONA NY **FANDAHARANA** IRAY KA NY **SORATRA FOTOTRA** NO SOLON'NY TSIRAIRAIM-PANGARO. **BAIKO** NO MANDRAFITRA AZY IO. ARY IREO BAIKO IREO DIA OMENA LAHARANA SY ALAMINA AVY AMIN'NY LAHARANA KELY MANKANY AMIN'NY LEHIBE. REHEFA ASAINA MANATANTERAKA IO **FANDAHARANA** IO AHO DIA IREO BAIKO VOALAHATRA IREO NO ASESIKO TANTERAHINA TSIRAIRAY



DIA MANDRAPIANDRY AN'IZAY ?

AMPIRIMINA AO AMIN'NY **TAHIRY FANDAHARANA** ALOHA IZY

IZAY IZANY ILAY ZAVATRA NENTINAREO NANDEHANDEHA MANKETSY MANKEROA TEO AN



FA MBA
INONA ARY NO
VINA VINAIN'ILAY
ZAVAVY INY ?



FANATANTERA-
HANA FANDA-
HARANA

OAY LEITY E,
AVERENO INY HAIN-
GANA. TSY MAINTSY
TANTERAHINA IZAO
DIA IZAO ILAY FAN-
DAHARANA

KLONG !



ENY ARY,
MANGALÀ EFITRA
TAHIRY IRAY IZAY
HOMENAO ANARANA
HOE **N** DIA ASIO **IRAY**
AO ANATINY

AZA MISAHIRANA IANAO.
HITAKO TSARA NY LALANA

NY FANDAHARAN'J SOFIA

1 OMENA SANDA 1 NY N

2 OMENA SANDA ANTSAPAKA EO
ANELANELAN'NY 1 SY 300 NY I

3 OMENA SANDA ANTSAPAKA EO
ANELANELAN'NY 1 SY 300 NY J

4 ALAINA NY A(I) TENY FAHA-I AO
AMIN'NY AN TOKON-TENY A

5 ALAINA NY B(J) TENY FAHA-J AO
AMIN'NY AN TOKON-TENY B

6 RAFETO (CONCATENATION)
 $M=A(I)+B(J)$

7 ATONTA NY N

8 EO AMIN'IO ANDALANA IO IHANY
MANONTÀ EFITRA FOTSY IRAY SY
NY TENY M

9 AMPIO 1 NY N

10 RAHA $N > 20$ MIJANONA
RAHA TSY IZAY MANDEHANA
AO AMIN'NY 2

DIA AVY EO IANAO MANDEHA ANY
AMIN'NY ANTOKOM-PIASA MPANAO
ANTSAPAKA MBA HANATANTERAKA NY
BAIKO 2 SY 3

INONA NO ATAO
HO ANAO ?

AN-TERY NY
FANAMIANA
MIHAJA

A... MILA ISA ROA I SY J
NATAO ANTSAPAKA TEO
ANELANELAN'NY 1 SY 300
AHO

ANTSAP

ALOHAN'NY HIDIRANAO DIA
IANGAVIANA AN-TANAN-DROA
IANAO HANAO ITY KENDA ITY

TSSS...
JIOLAHIM-
BOTO

mmm... MIALA TSINY
AHO FA TSY AZON'NY
BIBY IDIRANA ATO





NY ASA MARIKA TSIRAIRAY AO AMIN'NY SOLOSAINA DIA KARAZANA FANDAHARANA KELY DAHOLO. NY **FANAMBARANA**, NY **FAMPITOMBOANA**, OHATRA, DIA FANDAHARANA EFA VOARAKITRA HATRAMIN'NY VOALOHANY TAO AMIN'NY SOLOSAINA. IRENY RAFITRA IRENY NO ATAO HOE **ZANA-PANDAHARANA** NA "SOUS-PROGRAMMES". NY **CONCATENATION** KOA DIA ZANA-PANDAHARANA TOY IREO REHETRA AO AMIN'NY SOLOSAINA. A(I) SY B(J) DIA TOHIVAKANA LITERA.

AMIN'NY TENY LATINA NY CATENA DIA MIDIKA HOE **TOHI-VAKANA**. IO ZANA-PANDAHARANA IO IZANY DIA **MAMPITOHY** IREO TOHINDITERA ROA IREO HANOME TENY TOKANA IZAY AZO SORATANA HOE $M=A(I)+B(J)$



FA MBOLA MOSOARA
MIFATOTRA NA TSY
MIFATOTRA FOTSINY
ANIE IREO E!

AO HOE... RAHA VAO
JERENA DIA cosmo NO
AO ANATINITY

FANTATRAREO TSARA FA
IZAY REHETRA AMPIASAINA
ATO DIA OVAINA FANISA ROA
FOTOTRA DAHOLO, ARY
ANISAN'IZANY NY LITERA
SY NY TENY

B(J)

A(I)

ARY NY AO AMIN'NY
KITAPO B(J) DIA
phobe

IZAY FA
VONONA !

CONCATENATION

A(I)

B(J)

$M=A(I)+B(J)$

ENY ARY, ITO DIA
ATAO AO AMIN'NY
TAHIRY M

NA NY BÀ-KIRAROKO
AZA DIA EFA LEO BE
ANILAY MANDROSO SY
MIVERINA

O RY **BUFFER** A, BAIKO 7 SY 8,
ATONTAO NY RAKITRY NY **N** ARY EO
AMIN'IO ANDALANA IO IHANY, ASIO
BANGA SY NY RAKITRY NY TAHIRY **M**

AH, MILAY KOSA AN!
MANDEHA ILAY
FANDAHARAKO

MANDEHA
ILAY IZY!

PRRRRRRIIIII

1 cosmophobe

FANONTANA

TARATASY

STOP

ANDRANA

Cosmophobe! MAHAFINARITRA KOSA
IZANY AN. TSY MAINTSY MITADY NY
DIKAN'IO TENY VAOVAO NOFORONIN'NY
SOLOSAINA IO AHO. OHATRA HOE :
"ILAZANA NY OLONA TSY MAHATANTY
IZAO TONTOLO IZAO"

AO AMIN'NY 10
ISIKA DIA MANANA
FAMPITOHIZANA MI-
ANKINA AMIN'NY ZAVA-
MISY. MIANKINA AMIN'NY
FITSAPANA IRAY IZY IO.
RAHA TOA KA MIHOATRA NY
20 NY RAKITRY NY TAHIRY **N**
(IZAY LASA MANANA ANDRAI-
KITRA **FANDREFY**), DIA ASAINA
MIJANONA IZY. RAHA NY MIFANO-
HITRA AMIN'IZAY INDRAY DIA MIVERINA

ANY AMIN'NY **ADIRESY 2** AO AMIN'NY ANDIAM-BAIKONY ILAY FANDAHARA-
RANA ARY MAMERINA NY ASANY, DIA LASA INDRAY, MANATANTERAKA

TOHIBAIKO

DIA INONA NO MISEHO
RAHA TSY NISY IO
FITSAPANA IO ?

10
RAHA N=20
MIJANONA
RAHA TSY
IZAY
MANKANY
AMIN'NY 2

DIA LASA MANANA
FIFAMPITOHIZANA TSY MIANKINA ISIKA

IZANY HOE HANAO
TOHIBAICO TSY MISY FIAFARANY
ILAY FANDAHARANA, KA HAVERINY TSY
AN-KIATO IREO BAIKO MIFAMPITOHY

MAZAVA HO AZY SATRIA TSY NISY NITSINJO IZAY HIJANONANY. ISIKA
ATO MANTSY DIA MANATANTERAKA BAIKO FA TSY MISY MAMALIVALY
IZANY. ILAY FANDAHARANA ATAONTSIKA ITO IZAO DIA NOFORONINA
MBA HAMORONA TENY 20, IZANY HOE NATAO HIJANONA REHEFA
NAHAVITA TOHIBAICO 20. ILAY TOROLALANA "AMPIANA 1 NY N" DIA
ANTSOIN'NY VAZAHA HOE "INCREMENTATION" ARY MAHATONGA NY
TAHIRY N HO LASA MPANISA TOHIBAICO. FA NANDRITR'IZAY FOTOANA
NIRESAHANTSIKA IZAY DIA EFA NANDEHA NY MIKROSEGONDRA.

IZAO NY ZAVA-MISEHO
REHEFA MANAO FANDAHARANA
NEFA TSY MIERITRERITRA TSARA

NDEHA ITY FANDAHARANA ITY HOMEKO
ANARANA HOE

MILINTENY

17 Chronothérapeute
mpitsabo amin'ny
alalan'ny fotoana
18 Elastolithe
karazana vato fingotra
19 Mycoclaste
mpamaky olatra

14 Hémigame
Manana
antsasa-bady

NY **SOLOSAINA** IRAY DIA MANANA
 FIFAMATOPATORANA **BAIKO** MARO SY
 VONDRONA ZANA-PANDAHARANA IZAY AHAFANA
 MANAMBOATRA FANDAHARANA MILA HO
 TSY HITA ISA MIHITSY. NY OHATRA OMENA ETO
 DIA MIFANDRAIKA AMIN'NY **FANORATANA**
LAHATSORATRA. MISO IREO MIHEVITRA FA
 INDRAY ANDRO ANY DIA HO TERAKA AO ANATINY
 AO ILAY ANTSOINA HOE **HARANITA-TSAINA**
VOATROLOMBELONA.

EFA MANAMPY NY OLOMBELONA HANDAMINA HAINGANA
 IREO SORATRA FOTOTRA IZY, SY HANAO KAJY ARAK'ISA.
 MANDRANGITRA NY FAHAFAHANI SOFIA MITADY HEVI-
 BAOVAO IZY.

HATRETO ALOHA DIA NY OLOMBELONA NO TOMPO SY
 MPIAMBINA NY FAHAIZANY ARY FAHENO MATETIKA NY

HOE "**TSY AFA-MIHOATRA** IZAY NAMPIANARIN'NY
 OLONA AZY NY SOLOSAINA"

FA ANY AORIANA ANY, HANANA MASO, SOFINA SY TANANA IZY KA HO AFA-



MAHATSAPA NY TONTOLO IVELANY, **AMIM-PAHALEOVANTENA**

TANTERAKA ARY HANDRAY LESONA AMIN'IZAY IAINANY KA HO AFA-
 MANOVA IZAY FANDAHARANA RAKETINY AO, IZANY HOE "NY FOMBA
 FISAINANY" HAHATONGA AZY HAHEFA BEBE KOKOA SY HIFANARAKA BEBE
 KOKOA AMIN'NY TOE-JAVA-MISO.

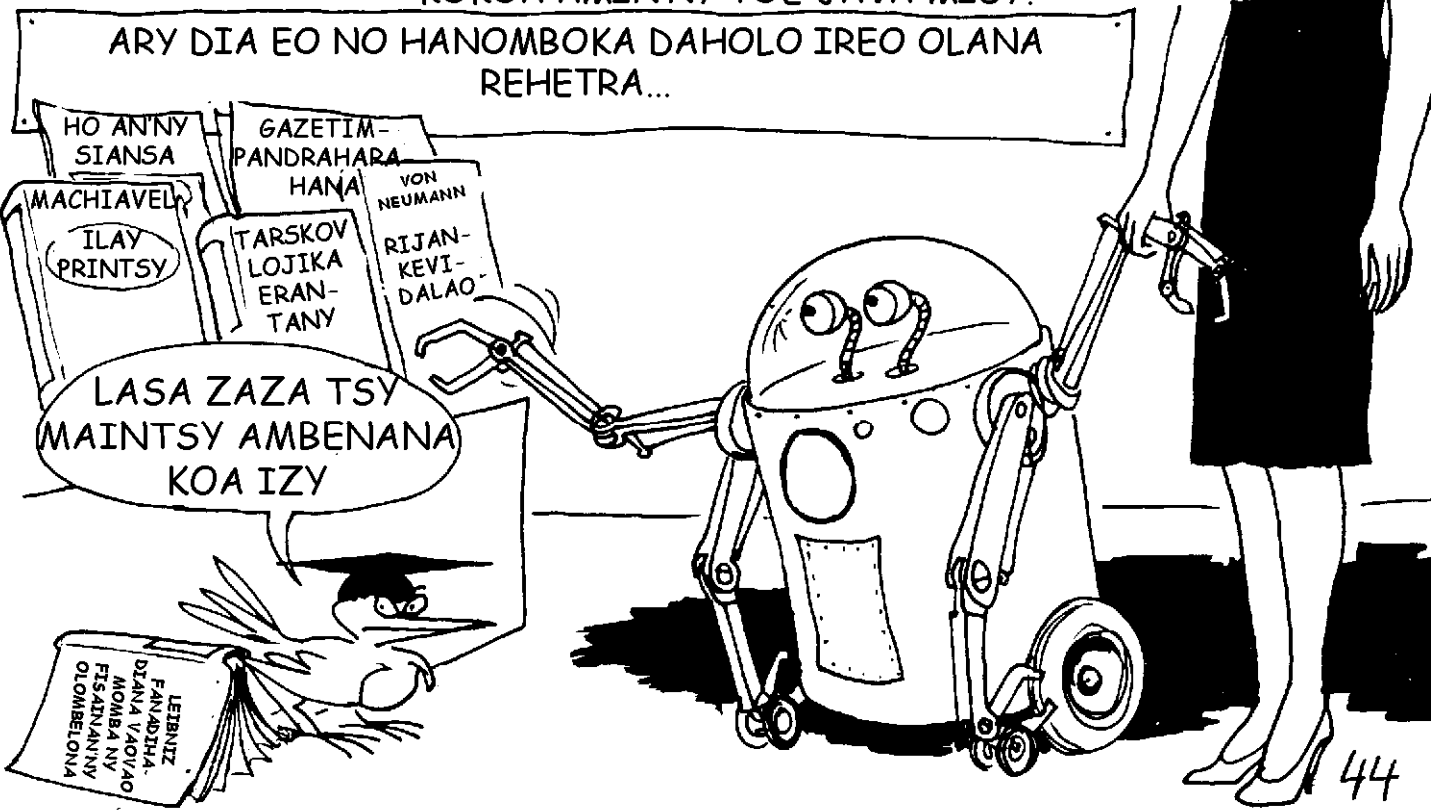

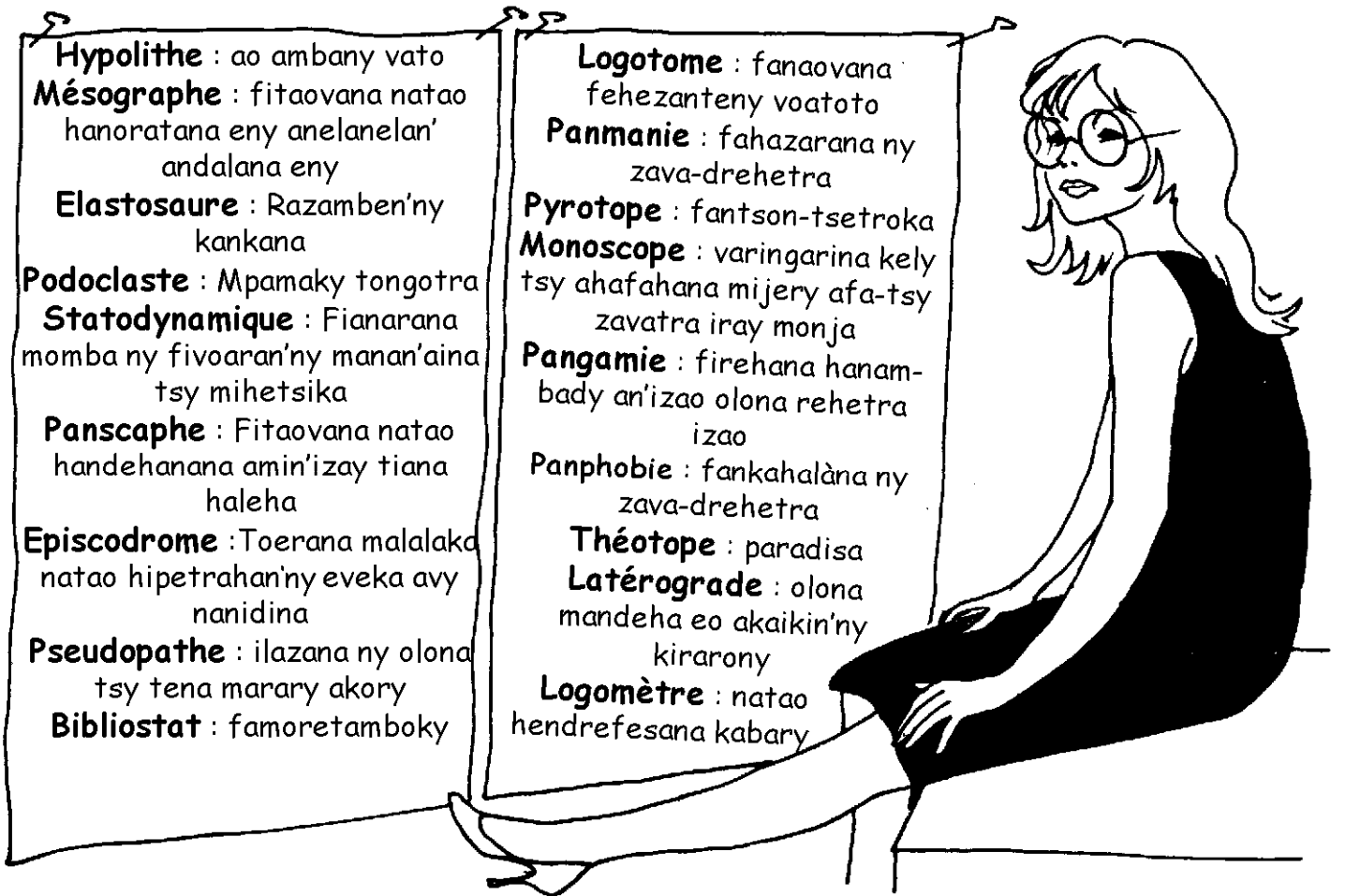

FA NANDRITRA NY FOTOANA NAHAVERY DIA AN'I SOFIA DIA NANOMBOKA NIHARATSY NY FANDEHAN-JAVATRA TAO ANATY SOLOSAINA...



TSY MAMALY RY ZAREO !
ALEO AMPIASAINA NY
FOMBA MAHERY VAIKA

FA... MISO
INONA ?



ENGA ANIE RY ZAREO
MBA TSY NANAONAO
FOANA TANY INDRAY. TSY
TOKONY NALEFAKO
NANDEHA IRERY TANY
MIHITSY IRENY

ANSELME
A!

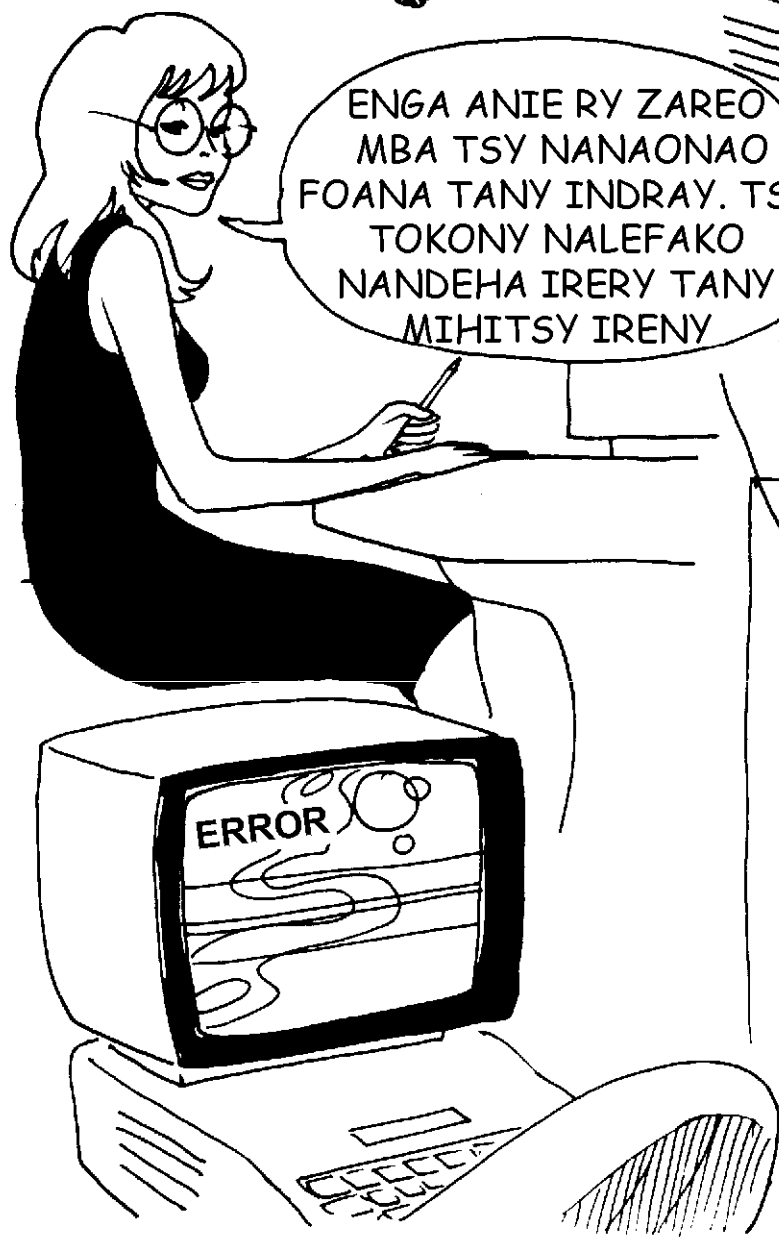



TENA VERY!... ENGA
ANIE MBA TSY...
ANDRIAMANITRO
Ô!



ALLÔ, NY TAHIRY FOIBE VE IZAO, ANI?!
FIHOARAM-PAHAFAHANA HOE E!
ANDRIAMANITRO Ô

ALLÔ, VONOV
DAHOLO NY ZAVA-
DREHETRA AO.
RENAREO VE ? IZY
REHETRA!

DRRIING



IZAY VAO NISY
KORONTANA TOY
IZAO!



AIZA I TIREZIASY,
ILAY SIFOTRA TEO ?

NIARAKA
TAMISNTSIKA IZY
TEO

FA TSY VITANAREO VE NY
MANARA-MASO AN'INY
AKAMANAREO INY E ?



TSY MAINTSY TADIAVINA
HAINGANA IZY RAHA TSY IZAY
DIA METY HOSIMBAINY NY
RAFITRA IRAY MANONTOLO



AHOANA NO HAHITANTSIKA AZY RAHA NANDALO ANY AMIN'NY
TOERANA FANOVA-MARIKA IZY ? METY HOE NIOVA NY MAHA-
LAHY NA MAHA-VAVY AZY...



TSY DIA OLANA LOATRA
IZANY, NY SIFOTRA
MANTSY SADY LAHY NO
VAVY

TSY HO TAFAVOAKA
ISIKA, TENA MINO
AN'IZANY AHO !

DIA LASA NITADY HAINGANA AN'I TIREZIASY I
ANSELME SY I MEGABIT

...NA METY HOE ANY AMIN'NY
MATEMATIKAN'NY TELOZORO
TELOLAFY IZY ! DIA AHOANA
NO HAHITANA AZY ?

MBA MANONTANY TENA
KOA AHO HOE AHOANA
ARY IZANY KÔSINAN'NY
SIFOTRA IZANY...

MORA ERY ILAY
MISANGISANGY. ARY
RAHA MBA IANAO NO
VOAN'IZANY?

LOZA ITY !

TENA
MAMOFOMPOFONA
ANSELME LANTURLU
IZANY TOE-JAVATRA
IZANY !...

TSY MISY
ISALASALANA INTSO-
NY FA AO ANATY SOLO-
SAINA AO RY ZAREO

IZATO FAHA-SIMBANA E!



ITO NY SORI-DRAFITRY NY ORINASA. ANDRAMANTSIKA TADIAVINA IZAY MISOY AN'ILAY SIFOTRAREO



MISOY MIANTSO IO!...

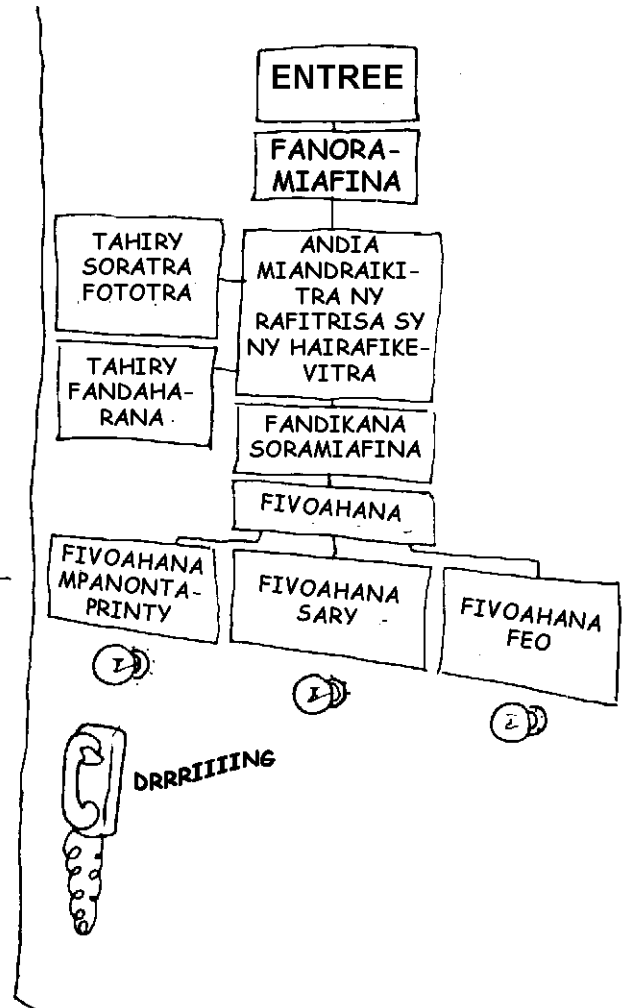

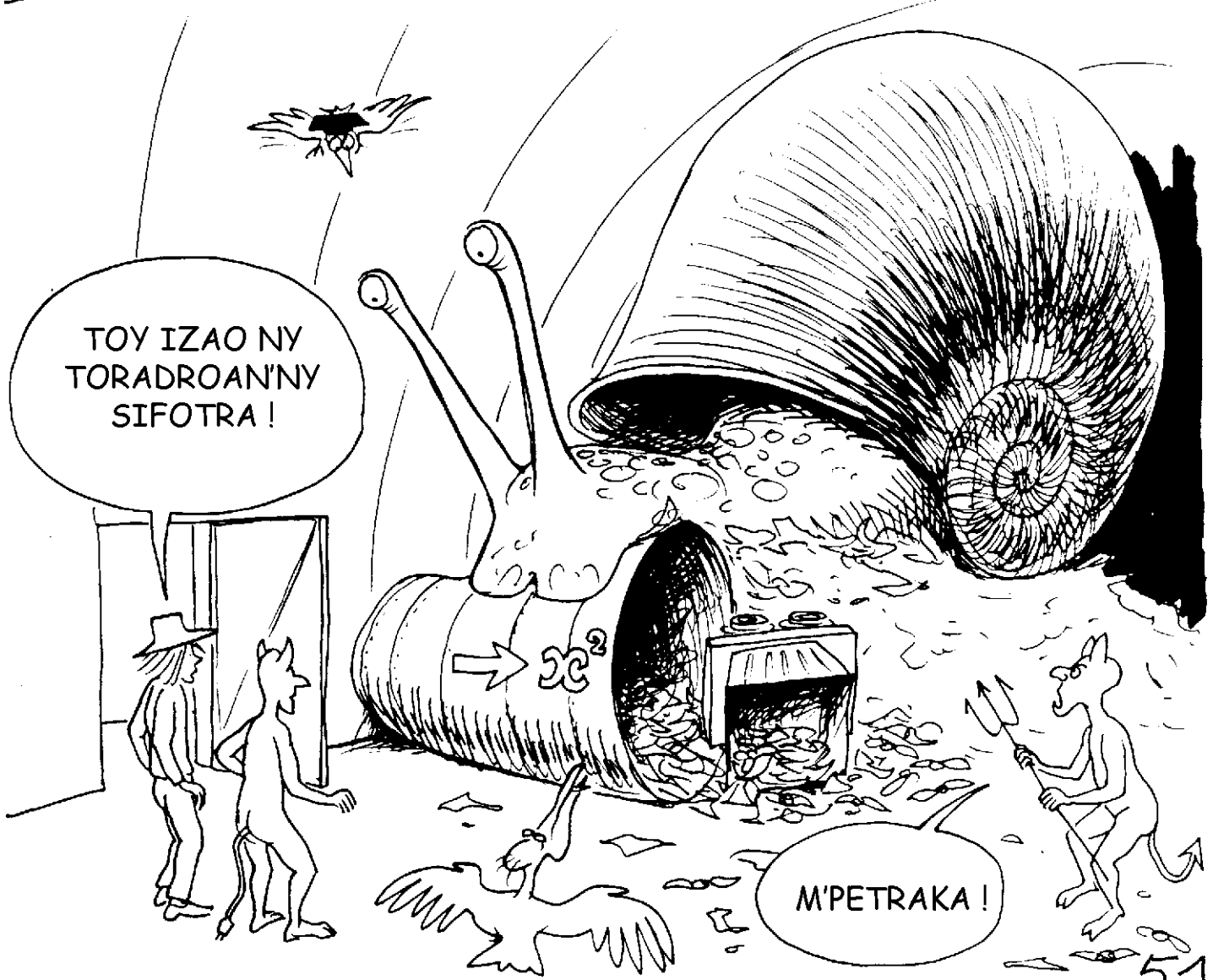

AZA BAIKOBAIKOANA
IZY FA TSY MANDAITRA
IZANY. HAMPITAHOTRA
AZY FOTSINY IZANY.

ARY ANDRIAMANITRA
IRERY IHANY NO MAHALALA
HOE INONA NY METY HO
VITAN'NY SIFOTRA
MATAHOTRA ANANKIRAY

METY TSY HO AZO
IRESAHANA INTSONY
IZY ARY HAMELY
AMIN'IZAY

MAZAVA BE FA TSY HO
TAFAVOAKA EO AMIN'NY
VARAVARANA MIHITSY IZY

mi !

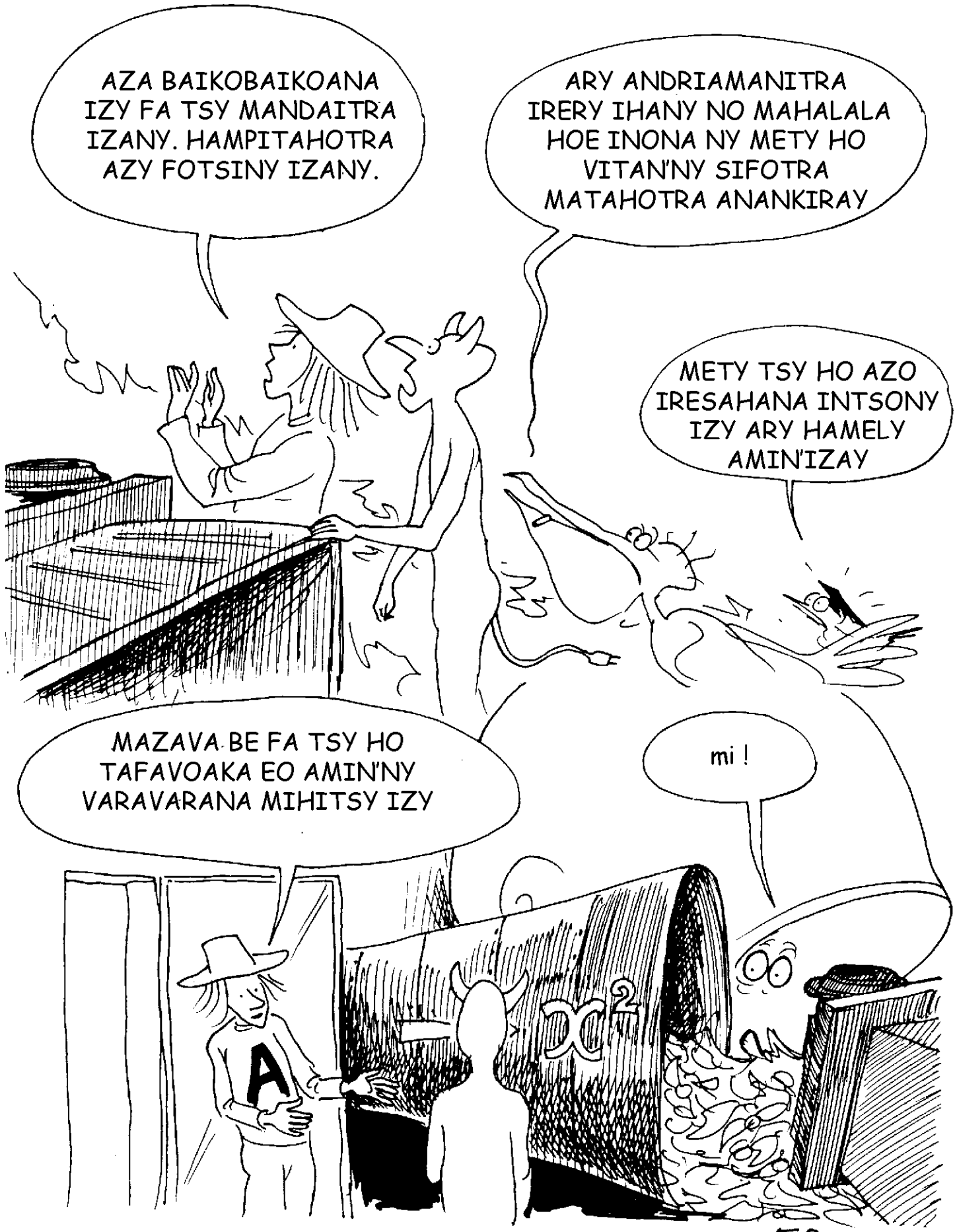

TOKANA IHANY NY
VAHAOLANA HITAKO :
ATAO NY FAKA
FAHAROANY

IZANY HOE ?

TSY MAINTSY
MIVERIN-DALANA
IZY

MITONIA RY
TIREZIASY A,
HAVOTANAY
IANAO

ALEFA, TIREZI-
ASY A, ALEFA !

mi !

IZANY KA MILIN-
DEVOLY !

ALEFA !

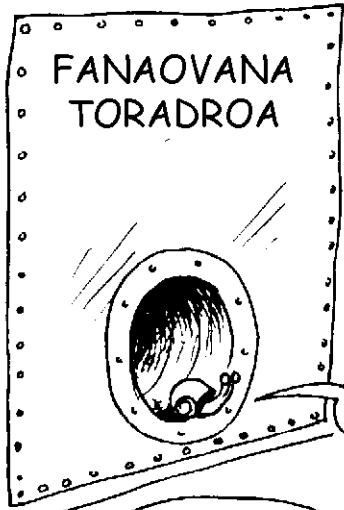

FANAOVANA
TORADROA

AVOAHY
TATO AHO!



IZAY, NANDAI-
TRA ILAY
HEVITRA!



ENY ARY, REHEFA IZAY
DIA TSY MAINTSY
AVERINA HATRAMIN'NY
VOALOHANY IZANY NY
TAHIRY REHETRA

FAFAO NY
TAHIRY

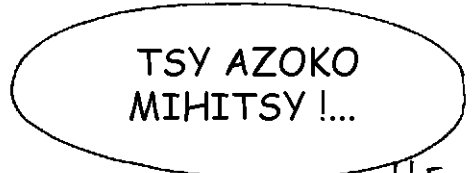

TSY AZOKO
MIHITSY !...

TSY METY TAPA-
KEVITRA MIHITSY
KOA RY ZAREO AO
AMBONY AO

TSY MAINTSY VAHANA
DAHOLO INDRAY IRETO
MOSOARA MIFATOTRA
IRETO...

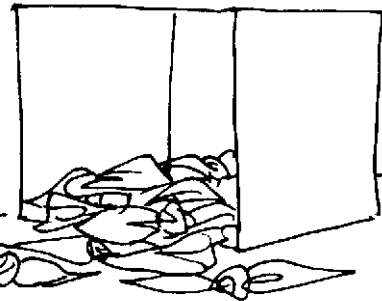

INONA NO
ATAONAREO ?

FOANANA
NY TAHIRY

NAHAZO BAIKO AVY
ANY AMBONY IZAHAY

INONA ARY NO
KETREHINY AO
AMBONY AO ?

IZA IZANY ?

A... SOFIA !

SOFIA ? ANTOKOM-
PIASA VAOVAO VE
IZANY ?

SOFIA...

... OH, AOKA IHANY, HO SAROTRA BE NY MANAZAVA IZANY AMINAREO.

A

A

OAY LEITY E,
TOA VIZANA BE
TAMPOKA TEO
AHO!

FA MISY
INONA?

MENA BE NY
MASONAO

TSY MISY INONA,
VIZAMBIZANA FOTSINY
ANGAMBA AHO

TSY MAHAGAGA. IANAO KOA
NAZOTO BE NIROTOROTO TEO!

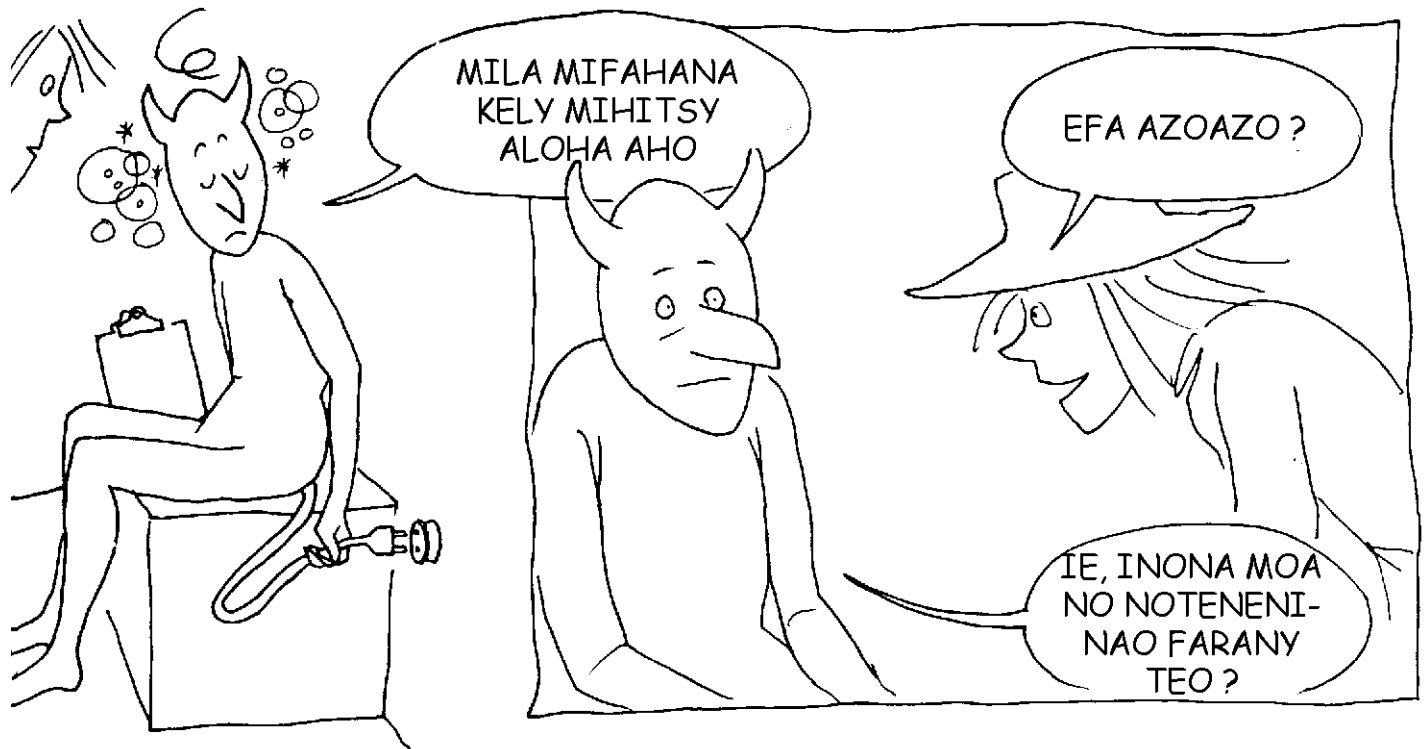

MILA MIFAHANA
KELY MIHITSY
ALOHA AHO

EFA AZOAZO ?

IE, INONA MOA
NO NOTENENI-
NAO FARANY
TEO ?

ENY ARY, NDEHA ALOHA HAMINTINA KELY. NY SOLOSAINA, VOALOHANY INDRINDRA, DIA **RAFITRA FIDIRANA-FIVOAHANA** NA "ENTREE-SORTIE". NY HABE REHETRA, NA INONA IZY NA INONA, DIA MIDITRA AMIN'NY TAHO IRAY ARY MIVOAKA AMIN'NY TAHO IRAY Hafa KOA. NY ZAVA-DREHETRA DIA VOASORATRA **ROA FOTOTRA** DAHOLO SATRIA TSY MAHAY MANISA MIHOATRA NY 1 NY MPIASANAREO.



IO FAMPIDIRANA IO DIA METY HO FITOHITOHIZAN'ISA SY LITERA SORATANA EO AMIN'NY KITENDRY. RAHA **MIVANTANA NY FAMPIASÀNA** ILAY SOLOSAINA (MODE D'UTILISATION DIRECTE) DIA AMPIDIRIN'ILAY **MPAMPIASA** TSIKELIKELY AVY AMIN'NY KITENDRY NY **TOROLALANA**. DIA TANTERAHINA EO NOHO EO IREO **BAIKO** IREO (PEJY 15-30)





ANDIAM-PIKARAKARA MANAM-PAHAIZANA MANOKANA
 NO MANATANTERAKA NY ASA, KA IREO DIA MANDRAY AN-TANANA
 NY HABE VOASORAMIAFINA **ROA FOTOTRA** (MOSOARA) ARY DIA
 MISOY FIVEZIVEZENA TSY AN-KIJANONA AO (**BUS**) MIARAKA
 AMIN'NY FITAHIRIZANA IREO AMPAHAM-BOKATRA

REHEFA IALOHAVAN-DAHARANA IREO
TOROLALANA DIA FANTATRY NY
 SOLOSAINA AVY HATRANY FA
TOROLALANA TSY TANTERAHINA EO
NOHO EO* IREO. NOHO IZANY DIA
 ANGONINA AO AMIN'NY **TAHIRY**
FANDAHARANA IZY IRENY



VOALAHATRA HO AZY AO AMIN'ILAY MILINA IRENY ARY
 IREO TOHIVAKAN-TOROLALANA MILAHATRA TSARA IREO NO
 ATAO HOE **FANDAHARANA**.



NY BAIKO VOAFARITRA TSARA SY
 VOASORATRA AMIN'NY ALALAN'NY
 KITENDRY NO MITARIKA NY
 FANATANTERAHANA IO ASA
 VOALAHATRA IO. IZAY ILAY
 ANTSOINA HOE **MIANTSO**
FANDAHARANA

FANATANTERA-
 HANA
 FANDAHARANA

RAHA NY MARINA DIA TSY VOASORATRA TOY
 NY AO AMIN'NY PEJY 37 IREO TOROLALANA.
 VOADIKA AMIN'NY **FITENY** MANOKAN'NY
 SOLOSAINA TSIRAIRAY AVY IZY IRENY.

MARO KARAZANA NY
FIVOAHAN'NY VOKATRY NY
 ASAN'NY SOLOSAINA
 (HORONAN-TSARY,
 MPANONTA-PRINTY, FEO)



58

(*) NdT : INSTRUCTIONS À EXECUTION DIFFEREE



TSY MISOY
HEVITRA HIVOAHANA
AMIN'IZAO
MIHITSY VE ?

HIVOAHANA
!?!

NTSSS, IRENY
TOROLALANA IRENY, IRENY BAIKO
IRENY, FANTATRAREO VE HOE AVY
AIZA IZY IRENY DIA MANKAIZA NY
VOKATRY NY KAJY ATAONAREO ?



ANGAMBA METY HO
SAMPAN-DRAHARAHA
Hafa IZANY TENENINY
IZANY E ?

AOKA RE E, TSY SAMPAN-DRAHARAHA
Hafa IZANY. NY TONTOLO IVELANY
IZANY, NY TONTOLO **AZO**
TSAPAIN-TANANANA !

NIERITRERITRA AN'IZANY
IHANY IZAHAY INDRAINDRAY. FA
ZAVATRA TSY METY HISY MIHITSY
IZANY. ERITRERETO NY **ANGOVO**
REHETRA ILAINA HANDIKANA
IZANY ZAVATRA REHETRA IZANY!

NY TIANAREO
HOLAZAINA IZANY DIA
HOE... IRENY ASA MARIKA
REHETRA IRENY, IRENY KAJY
REHETRA ATAONTSIKA IRENY,
DIA METY HANANA HEVITRA
MIVAINGANA, HANANA DIKA
AZO TSAPAIN-TANANA !



IZANY AN!

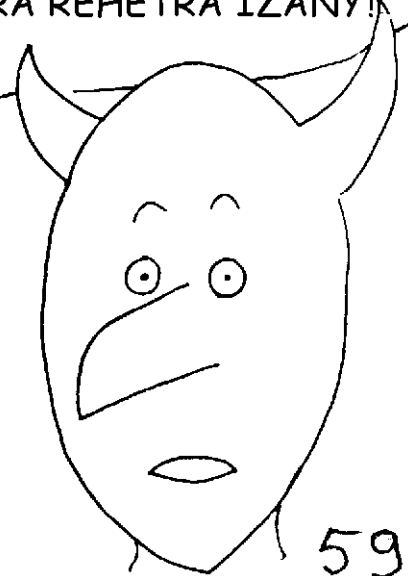

HERINARATRA TSY MISY ANTONY AKORY NO MAMPANDEHA ANAREO ETO. MANAKAIKY NY AMPAHARIVON'AMPERA

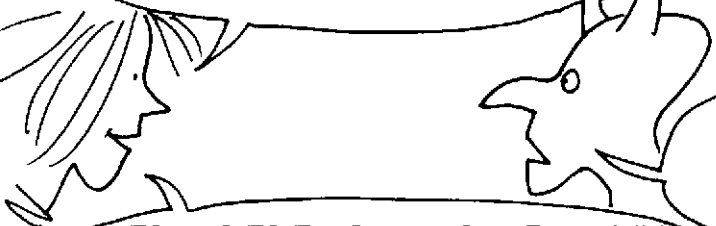

MAMPIESONA AHY VE IANAO E?



ZATO AMPERA... ANDRIAMANITRO Ô!...

ERITRETO TSARA FA ANY **IVELANY** ANY, NY FAMELOMANA FIARAKODIA IRAY FOTSINY DIA EFA MANDOA MIHOATRA NY ZATO AMPERA

TOA TSY HAHAFAHANA MIVOAKA ANGAMBA ITY



AIZA NO AMETRAHANAREO NY VALIN-KAJY ATAONAREO ?



ATO

mmm...



TIREZIASY ! AMPY IZAY DITRANAO ANDROANY IZAY

TE-HIVOAKA TATO AHO !

HIDITRA ATO VE... KAY LEITY E...

FIVOAHANA

FANDIKANA SORAMIAFINA

NAHA VOARAY FAMPIDIRANA ISIKA !

I SOFIA IO, MIANTSO ANTSIKA IZY



HAIN-GANA !

ANSELME ?

ALLÔ, MANANA EFITRA TAHIRY MITONDRA NY ADIRESY HOE A-N-S-E-L-M-E VE IANAREO ?



ME ?



TSIA R'ILAY APONDRALAHY ITY A. IZAHO IZANY ANSELME IZANY !

ALLÔ, NY TAHIRY FOIBE NO
MAMALY ANAO IZAO. TSY
MANANA N'INON'INONA
MITONDRA IO ADIRESY IO
IZAHAY

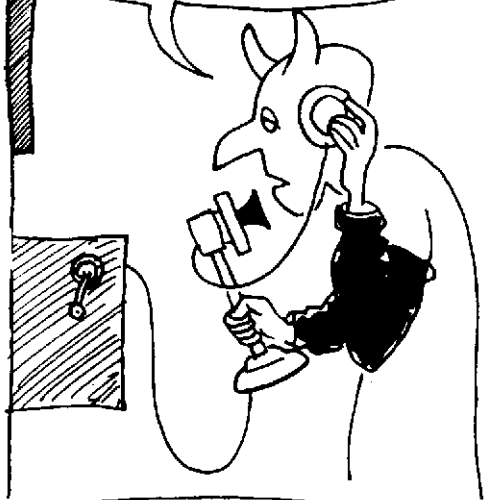

K'EFA HOE **IZAHO**
IZANY **ANSELME**
IZANY HO' AHO !!!



ENY E... MAZAVA HO AZY...
KANEFA FANTATRAO TSARA
FA... NY TOROLALANA E...
AZAFADY

TSY MAINTSY HOE
MANAVO-TENA IRERY
IZANY !!!



REHEFA TOKONY
HANDEHA DIA TSY
MAINTSY MANDEHA !

FA IZAHO VE IZAO
TEZITRA E ?



AO FA HANTSOIKO
IANAO REHEFA AVY
EO... MISY OLONA ATO
AMIN'NY BIRAOKO

LASA !

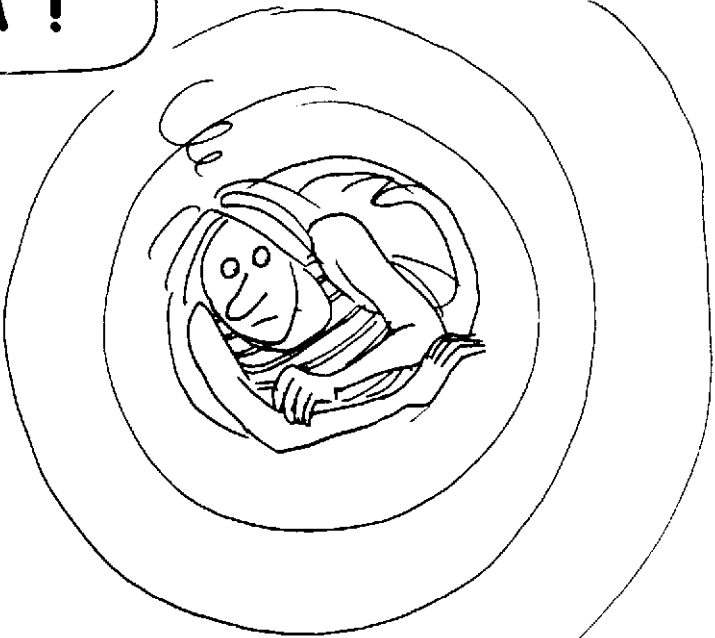
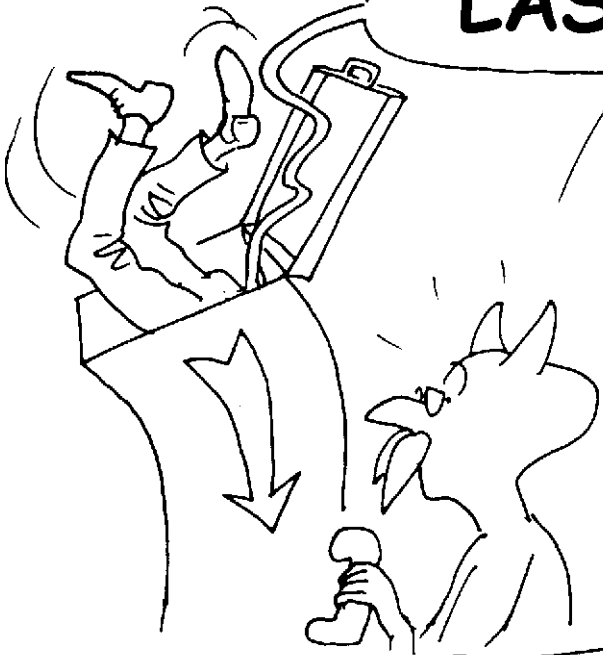

AH, MBA TSY TOKONY HANAO KAJY KOSA RY ZAREO AMIN'NY FOTOANA TOY ITONY E !



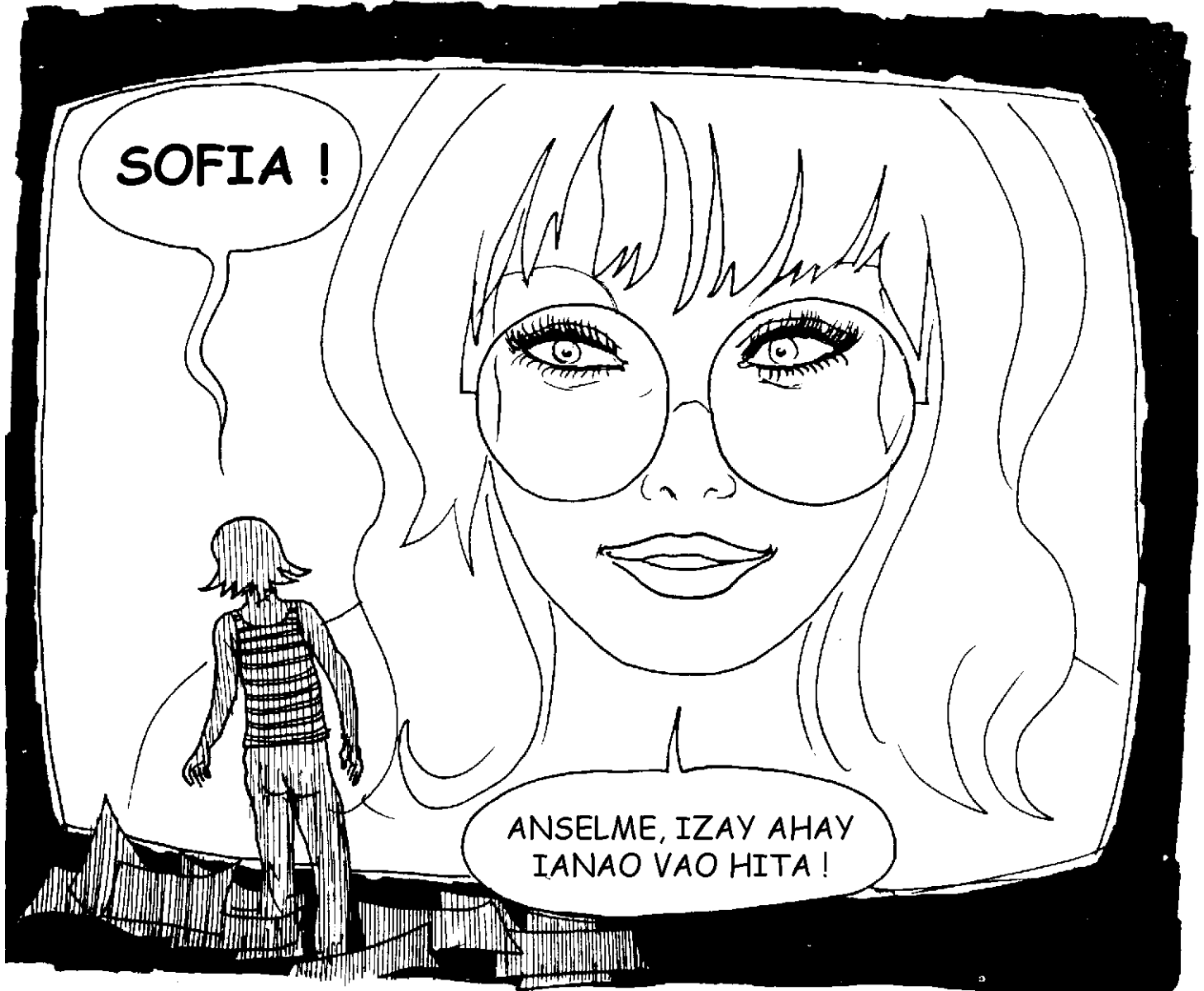
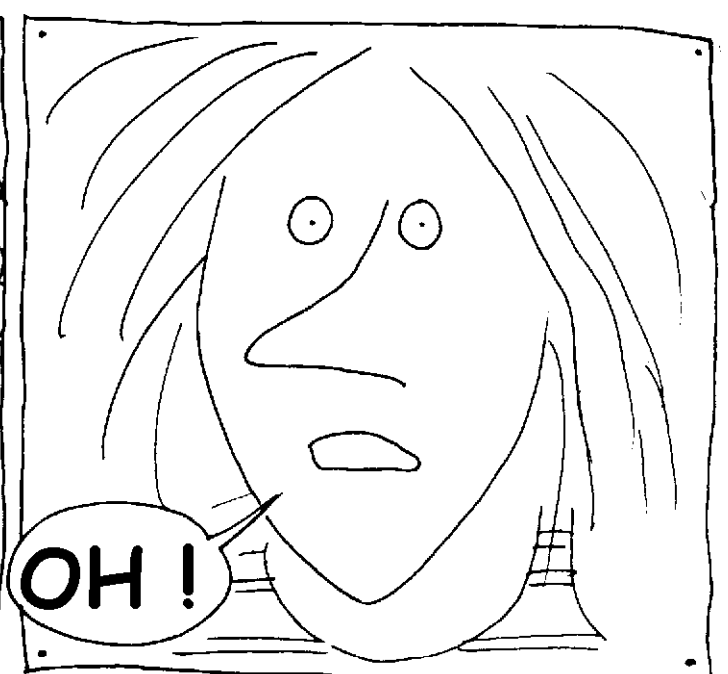
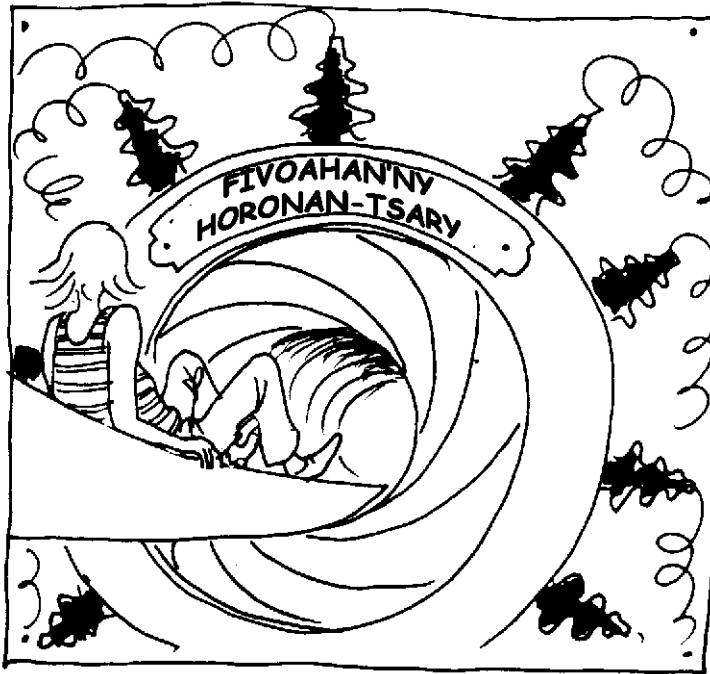



FALY MAHITA
 ANAO SALAMA
 TSARA INDRAY AHO.
 KANEFA TSY HO
 AFAKA AVOAKA
 AMIN'NY
 ALALAN'ITY
 HORONAN-TSARY
 ITY IANAREO. TSY
 VITA IZANY RAHA
 ARA-PAHAIZANA
 MANOKANA

NATAONAREO AIZA ILAY
 BOKY FIANARANA MAMPIASA
 NY SOLOSAINA ?

ILAY BOKY
 FIANARANA ?

NOTADIAVIKO
 HATRAIZA
 HATRAIZA ILAY IZY



MAINA
52384

METY TAFIDITRA ATO
AMIN'NY SOLOSAINA
NIARAKA TAMINAY KOA IZY
TAMIN'IZAO
NAMPIDITRA ILAY
TOROLALANA
MASINAMASINA



TSY HAIKO HOE INONA NY
TOROLALANA AHAFAHANA
MAMOAKA ANAREO AO.
METY AO ANATIN'ILAY
BOKY NO MISO AN'IZANY.
TSY MAINTSY
TADIAVINAO IZAY



OK!

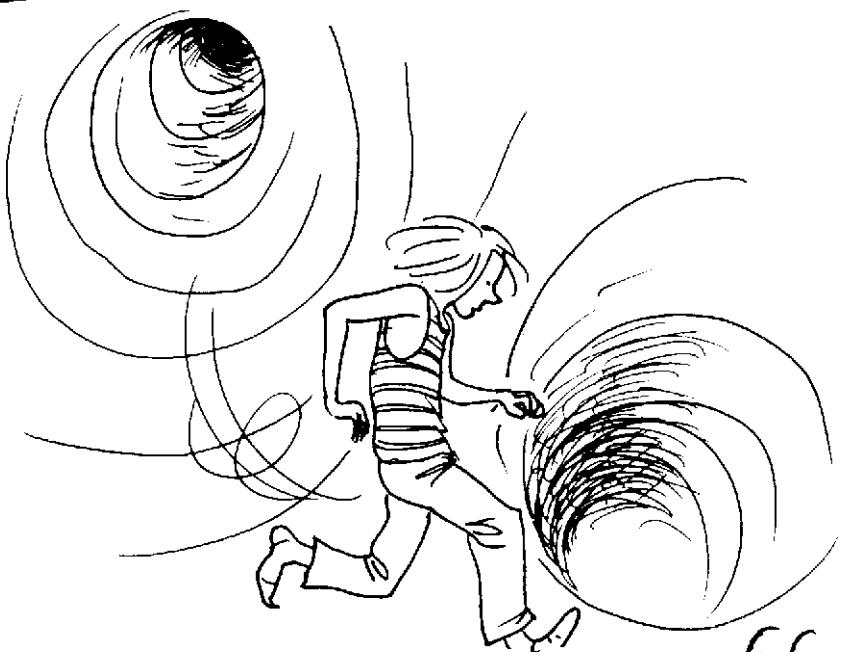
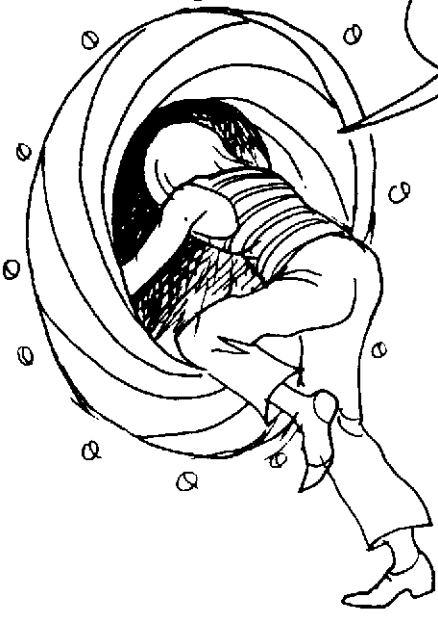

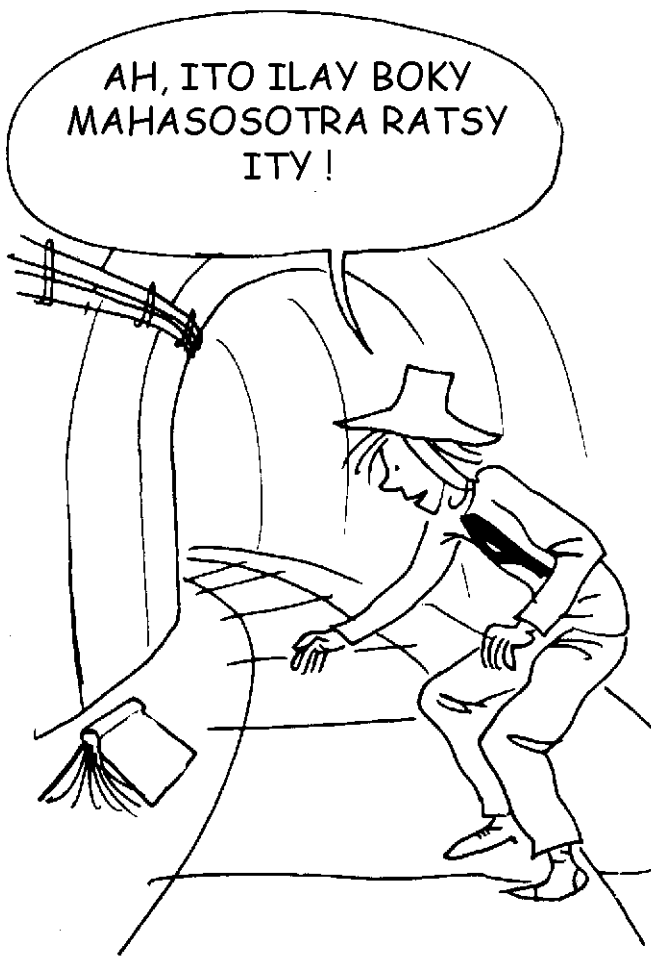
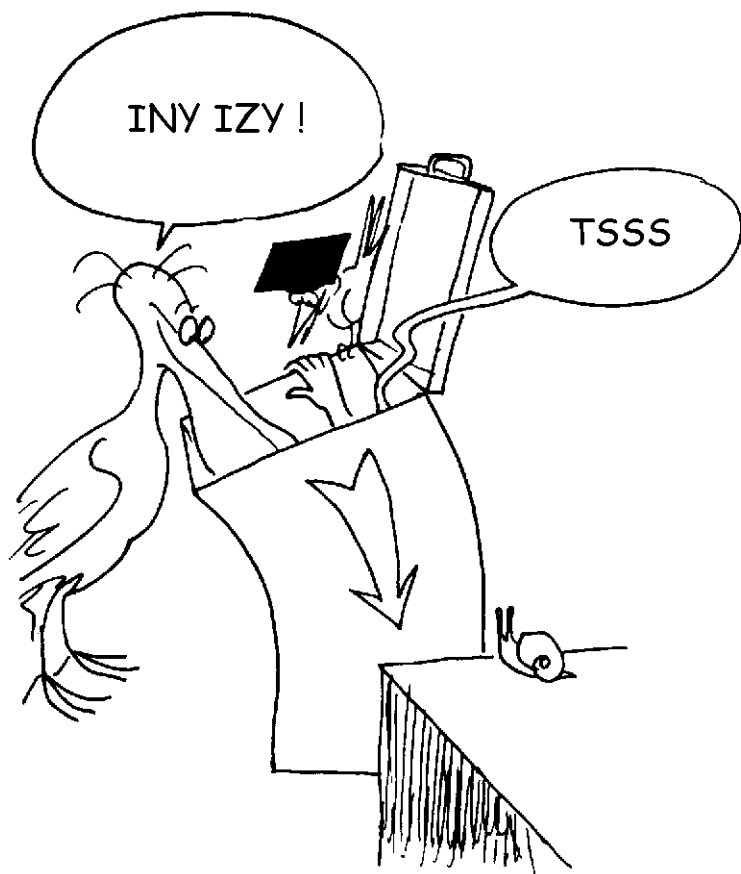



RAHA HIVOAKA IVELAN'NY
SOLOSAINA :
TENDREO :
TSY MASINAMASINA (ARY
MAZAVA HOA AZY, RETURN)
IO TOROLALANA IO DIA
MANAFOANA NY TORO-
LALANA MASINAMASINA

ITO !



AFAKA MANDEFA
HAFATRA AMIN'NY
FAMOAHANA VE AHO ?

IE, MANANA
FAMOAHAM-PEO METY
HANDAITRA ISIKA



SOFIA A, TSY
MAINTSY MANORATRA
NY TOROLALANA TSY
MASINAMASINA
IANAO

OK!

ARY, MAZAVA HO
AZY, TSINDRIO
NY RETURN

HIARAKA AMINAY
VE IANAO ?

A
HIARAKA
AMINAREO ?
'ZA... A...

HAINAREO FA ATO
ANIE NY FIAINAKO E

FIKAJIANA NY DOSE LETHALE DE TABUN
1) VOKANY AMIN'NY KAMBANTSOLA

SADY INDRANDRAY KOA IZAHAY ASAINA MANAO KARAZAN-KAJY MARO

FIKAJIANA NY FETRAN-DANJAN'NY ZAKA MPITRIATRA
FOTOANA LANY :
$$z = \frac{1}{m \cdot Q \cdot \lambda}$$
$$z' = \frac{2}{\lambda}$$

FOTOANA IPARITAHANY
KAJIM-PIAROVANA
(CH3)2C2H2CN

SORI-TORAKY NY
$$L = 4 \times 10$$
$$M = 1210 \text{ kg}$$
$$v = 280 \text{ km/h}$$
$$h = 340 \dots$$

TAHIRIN-FADIDINTREO

... ARY IZAO, KOA SATRIA IANAREO EFA NAHARESY LAHATRA AHY HOE MANANA DIKANY AZO TSAPAIN-TANANA DAHOLO IZAO REHETRA IZAO, INDRANDRAY AHO MANONTANY TENA HOE TSARATSARA KOKOA NOHO NY ATO VE IO TONTOLO IVELANY IO.



TENA IZY IZY

INONA RE ITY E!

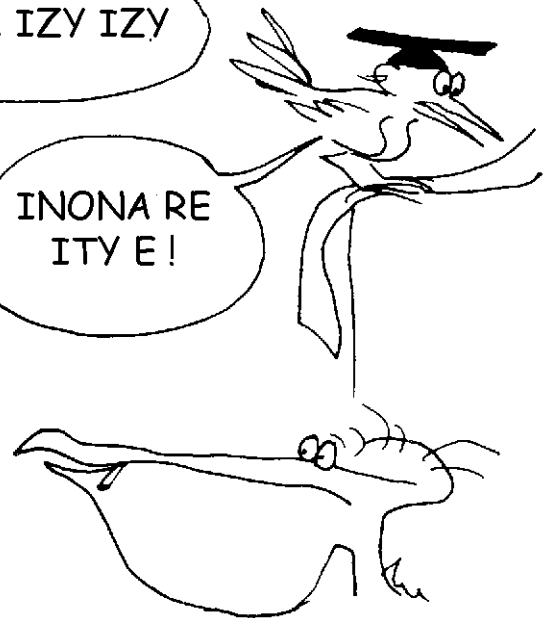

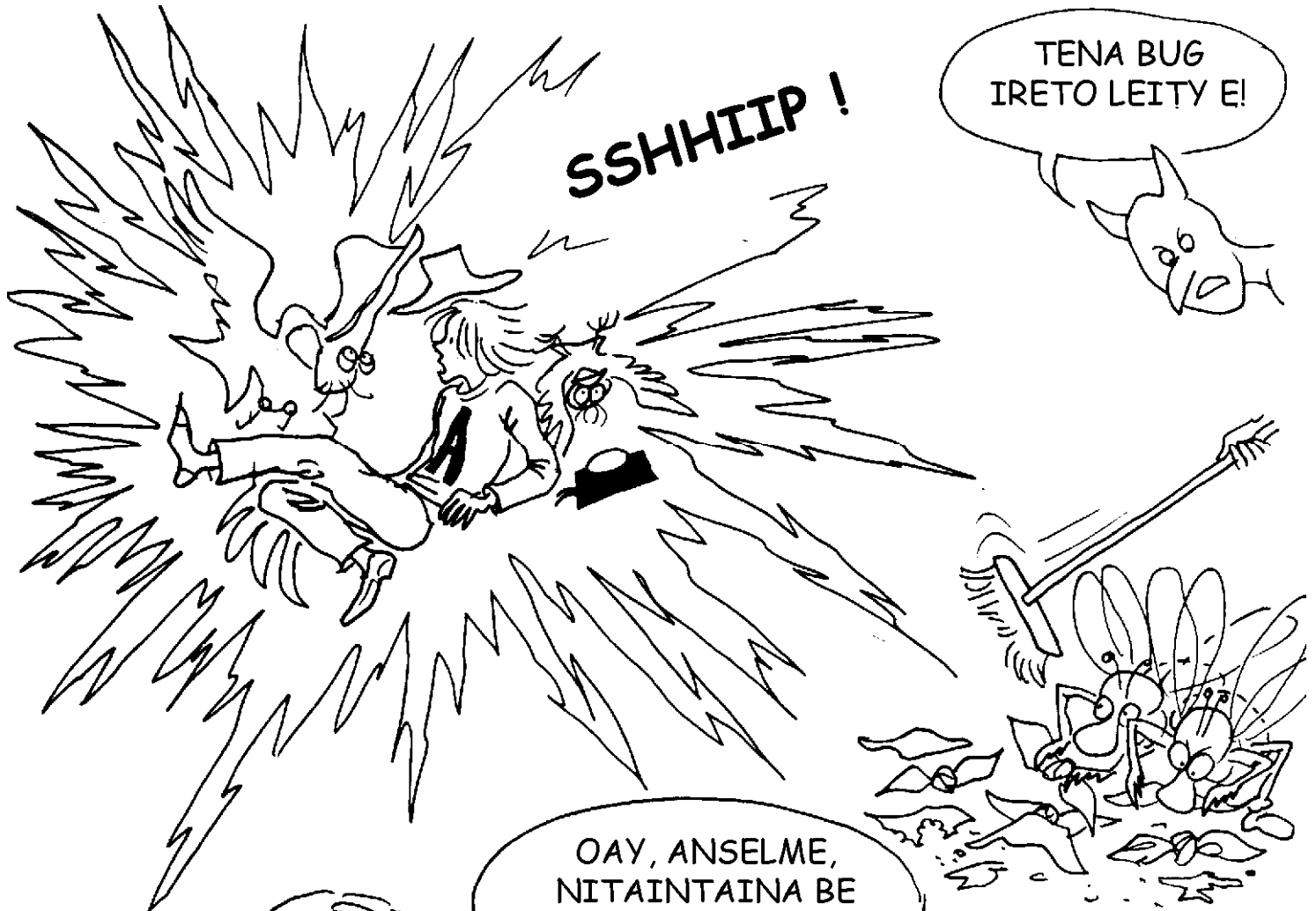

OAY, ANSELME,
NITAINAINA BE
AHO!



FA NANOMBOKA TAMIN'IO ANDRO IO DIA NANANA OLANA
TSY FANTATRA MAZAVA ILAY SOLOSAIN'NY IVONTOERANA
ARY TSY NISY NA DIA IRAY TAMIN'IREO MANAM-PAHAIZANA
AZA NAHAVITA NAMAHA NY OLANA. ANGAMBA METY HO NY
KIRARON'I ANSELME LANTURLU NO NIRAIKITRA TAO
ANATINY TAO...

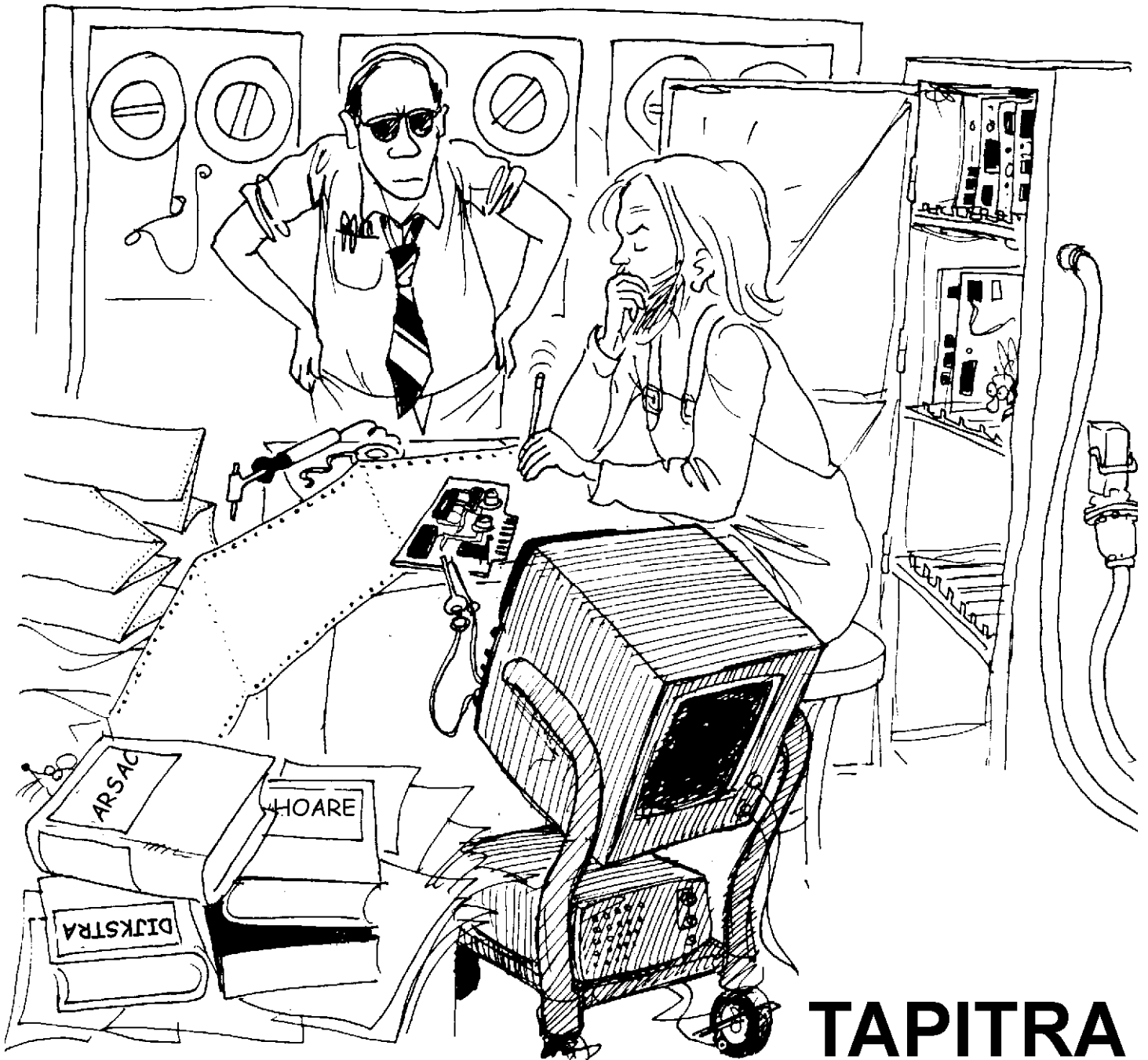

TAPITRA



MALAGASY

ARAK'ISA
 EFI-TAHIRY
 FAHAFAHANA
 FAMPITOMBOANA
 FANAMBARANA
 FANDAHARANA
 FIZARANA
 KAJIMIRINDRA
 KITENDRY
 MARIKA
 MATEMATIKAN'NY TELOZORO TELOLAFY
 MPANONTA-PRINTY
 RAKITRA
 ROA FOTOTRA
 SORAMIVADIKA
 SORATRA FOTOTRA
 TAHIRY
 TAHIRY FANDAHARANA
 TAHIRY FOIBE
 TORA-DROA
 TSIRAIRAIM-PANGARO
 VOATROLOMBELONA

FRANTSAY

NUMERIQUE
 CASE MEMOIRE
 CAPACITE
 MUTIPLICATION
 ADDITION
 PROGRAMME
 DIVISION
 INFORMATIQUE
 CLAVIER
 SIGNE
 TRIGONOMETRIE
 IMPRIMANTE
 CONTENU
 BINAIRE
 BOUSTROPHEDON
 DONNÉE
 MEMOIRE
 MEMOIRE PROGRAMME
 MEMOIRE CENTRALE
 CARRÉ (ELEVATION AU CARRÉ)
 INGREDIENT
 ARTIFICIEL

Iaraha-mahalala fa tsy ny Malagasy rehetra akory no manana rakibolana ahafahany mijery izay teny tsy fantany. Iaraha-mahalala koa fa amin'ny teny frantsay ny fampianarana any amin'ny ambaratonga rehetra. Teo am-pandikàna ity boky ity ho amin'ny teny malagasy ary dia niharihary fa tsy ho takatry ny mpamaky rehetra ny voambolana hampiasaina ato. Ka rehefa nandinika izahay dia nanapa-kevitra fa hasiana fanazavana ireo teny sarotra rehetra miaraka amin'ity boky ity mba ho tratra ny tanjon'ny SSF amin'izao asa fampielezana ataony izao.

Nous savons tous que seule une minorité malgache peut s'offrir le luxe de posséder un dictionnaire. Nous savons aussi que l'enseignement, à Madagascar, se fait en français. En toute connaissance de cause, et au cours de notre travail de traduction, nous en avons conclu que seule cette minorité pourrait comprendre les mots scientifiques utilisés dans cet album. Après réflexion, donc, nous avons décidé d'inclure ce lexique afin que le but de SSF soit atteint à travers cette vulgarisation.

Tantely RANDRIAMITANTSOA