

Ubumenyi butagira Imipaka

Itegeko ryo mu 1901 rigenga amashyirahamwe

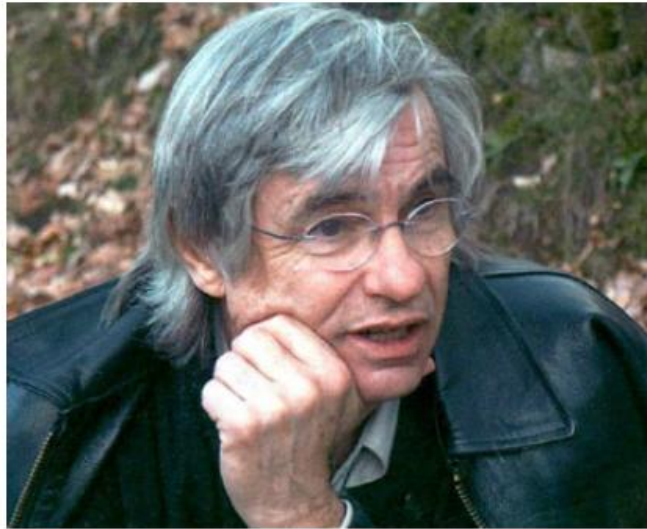

Jean-Pierre Petit, Perezida w'iri Shirahamwe

Uyu Jean-Pierre Petit, Peresida w'iri shyirahamwe ry'Ubumenyi butagira Imipaka, yahoze ari diregiteri w'ubushakashatsi mu kigo cy'inzobere cya CNRS, mu Bufaransa. Akaba kandi inzobere ihanitse muri Fizike y'inyenyeri (Asitorofizike); yahimbye uburyo bushyashya by'inyandiko bita: *Ibitabo by'amashusho by'ubumenyi*. "Ubumenyi butagira Imipaka" ni ishyirahamwe ryahimbwe mu 2005 n'abagabo babiri, Jean-Pierre Petit na mugenzi we Gilles d'Agostini. Iri shyirahamwe ryihaye intego yo gukwirakwiza kw'isi hose ubumenyi ku buntu harimwo n'ubumenyi bwa tekhnike, ubukorikori n'ikoranabuhanga. Iri shyirahamwe ribeshejweho n'inkunga rihabwa. Izo nkunga nizo ziriha abantu bahindura inyandiko mu zindi ndimi. Buri nyandiko (igitabo cy'amashusho cy'ubumenyi) ihindurirwa mu rundi rurimi ku mafaranga angana n'amayero 150 (150 euros) kuva mu 2007 kugeza ubu. Iri shyirahamwe rinariha amafaranga ajyanye n'iyoherezwa ucishije muri banke ry'ayo mafaranga y'ihinduranya mu zindi ndimi. Abahinduranyi b'indimi bagiye bongera, buri munsu, umubare w'ibyo bitabo bisomwa hose k'ubuntu. (Nko kugeza mu 2007, hari hamaze kuboneka ibitabo magana abiri (200) bikurwa kuri interineti k'ubuntu kandi byanditse mu ndimi makumyabiri n'umunani (28) harimwo ikinyarwanda n'ururimi rwo muri Lawosi).

Biremewe ko iki gitabo gikopororwa cyangwa gifotorwa, cyose cyangwa igice; kinakoreshwa n'abarimu mu masomo ariko mu buryo butari uburya inyungu z'amafaranga. Gishobora gushyirwa mu masomero y'uturere, y'amashuri cyangwa ya za kaminuza, cyanditse ku mpapuro cyangwa cya shyizwe mu miyoboro y'imbuga z'ikoranabuhanga zigose (intranet).

Uyu mwanditsi w'ibi bitabo yatangiye kwandika ibindi byo byoroshye kandi bigenewe abana bato (bari mu rugero rw'imyaka 12). Ibindi biriho bikorwa n'ibitabo by'amajwi avuga, bigenewe abatazi gusoma cyangwa abashaka kwiga urundi rurimi rutari urwo bakuriyemwo.

Iri shyirahamwe rishaka buri gihe abahinduranyi b'inyandiko bazishyira mu ndimi zabo zakavukire ariko bafite ubuhanga buhagije bwo gutanga inyandiko mpiduranyi nziza z'ibitabo basomye.

Ushatse kugira icyo ubaza cyangwa ugeze kuri iri shyirahamwe, wajya ku rubuga rwaryo ku interinete aha hakurikira: <http://www.savoir-sans-frontieres.com>

Iranga-konti mu Bufaransa → Inyandiko ngaragaza mutungo muri (RIB)

Ikigo	Umwanya wo kwakiriramo amafaranga	Nimero ya konti	Urufunguzo rwa RIB
20041	01008	1822226V029	88

Aho ikorera: Banki ya Posita
Hagati y'Umujyi wa Marseille
13900 Marseille CEDEX 20
Mu Bufaransa

Mu bindi bihugu → Ibanki Mpuzamahanga (International Bank) Nimero ya Konti (IBAN):

IBAN
FR 16 20041 01008 1822226V029 88

→ N' Inyandikobanga ya banki (BIC) :

BIC
PSSTFRPPMAR

Amategako agenga iri shyirahamwe agaragara ku rubuga rwa yo kuri interineti. Imibare ngaragaza mutungo nayo irahari kandi ihora ishyirwa ku gihe. Iri shyirahamwe nta mafaranga na make rikura ku nkunga rihawe uretse ayo kohereza, bicishijwe muri banki, ahemba abahinduranyi b'indimi ku buryo babona abagenewe yose. Nta munyamuryango w'iri shyirahamwe n'umwe rihemba kuko bose ari abakoranabushake.

Abanyamuryango ubwabo nibo barihira amafaranga ishyirahamwe rikoresha ngo ribeho nk'ayo kwishyura no gukoresha urubuga rwa yo rwo kuri interineti kuko ayo atarihwa n'ishyirahamwe.

Bityo mugaragarizwa neza uko umutungo w'ishyirahamwe ukoresheka kandi mukibonera ikizere ko, muri iyo "mirimo y'ubwitange mfashamuco", inkunga yose mutanga ikoresheka neza mu kwishyura abahindura ibitabo mu zindi ndimi.

Dushyira ku rubuga rwa interineti buri kwezi, ugereraniye, nk'ibitabo cumi bihinduwe mu zindi ndimi.

UBUMENYI BUTAGIRA IMIPAKA

IBINTU BYOSE BIFITANYE ISANO

Johani-Petero Petit



Byahinduwe na :
Mohamed Abdel aziz Kamanzi

<http://www.savoir-sans-frontieres.com>

kandi Ikindi,
ni ukuri







Sofi,
rimwe na rimwe
njya nibaza...

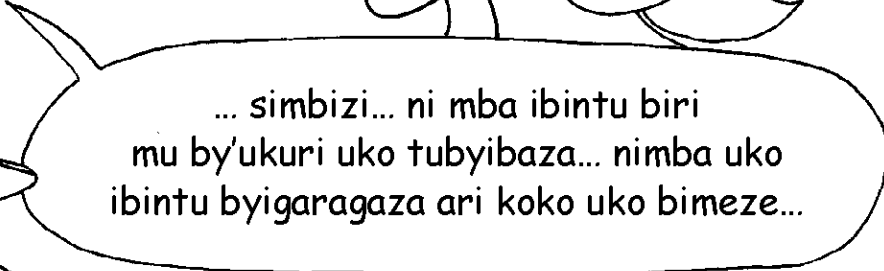

Iki, nshuti ya nje ?



... simbizi... ni mba ibintu biri
mu by'ukuri uko tubyibaza... nimba uko
ibintu byigaragaza ari koko uko bimeze...



Nimba nta
bintu biri inyuma
y'ibindi...



Ni ukwitonda ! Iniveri
imwe ishobora guhisha iyindi !



Ubishatse wajya kubyirebera.

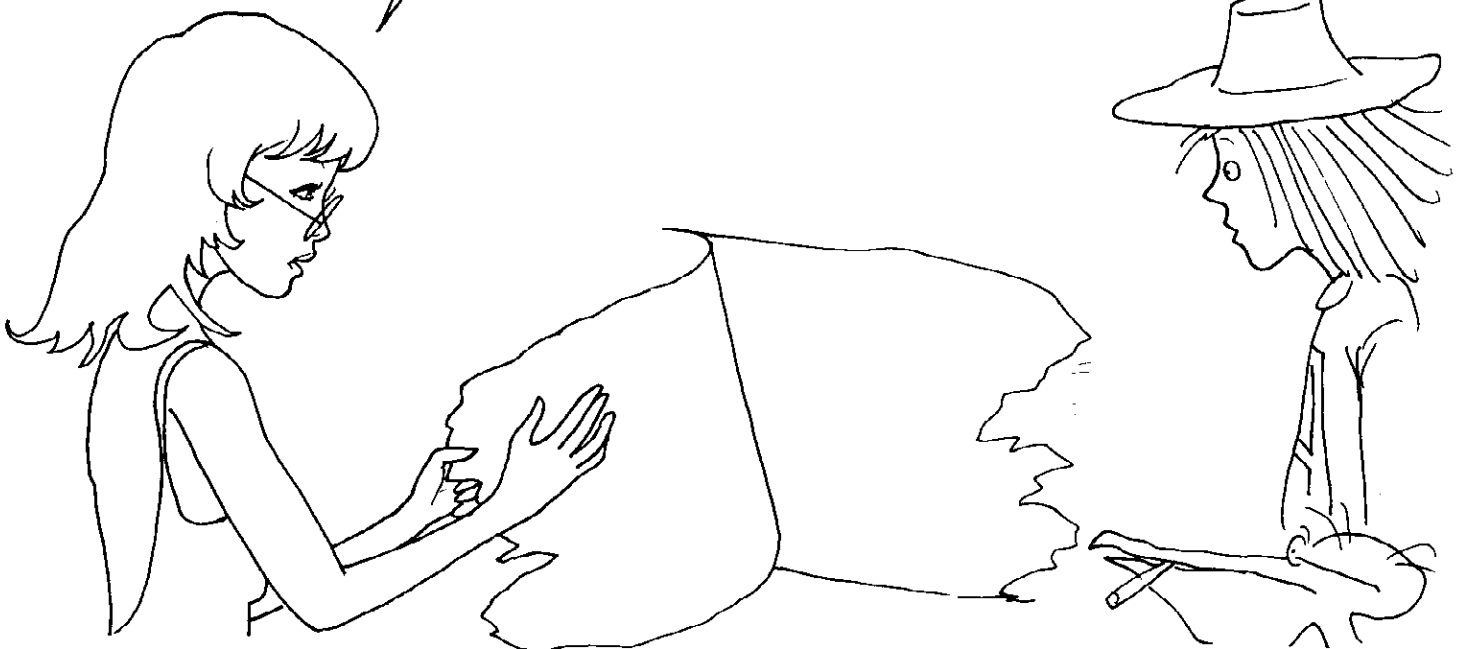

Hari umuntu uriho uvuza umwirongi.



Dore twageze mu buvumo bwa fizikye.



Disi gwino!
Tugiye kwiga amayeri meza!

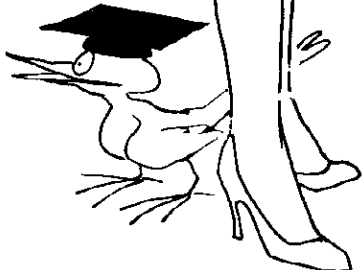

PARIKYE KOSIMIKYE

Bwana Aluberiti

nyirabyo-wabishinze



Biturutse
hariya.

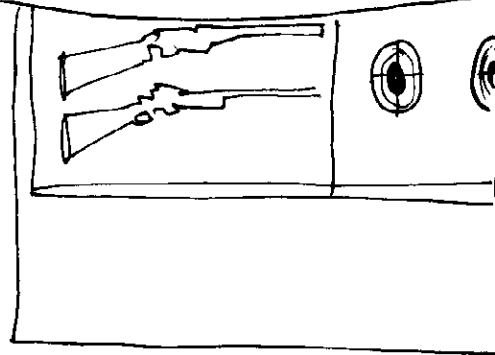

al

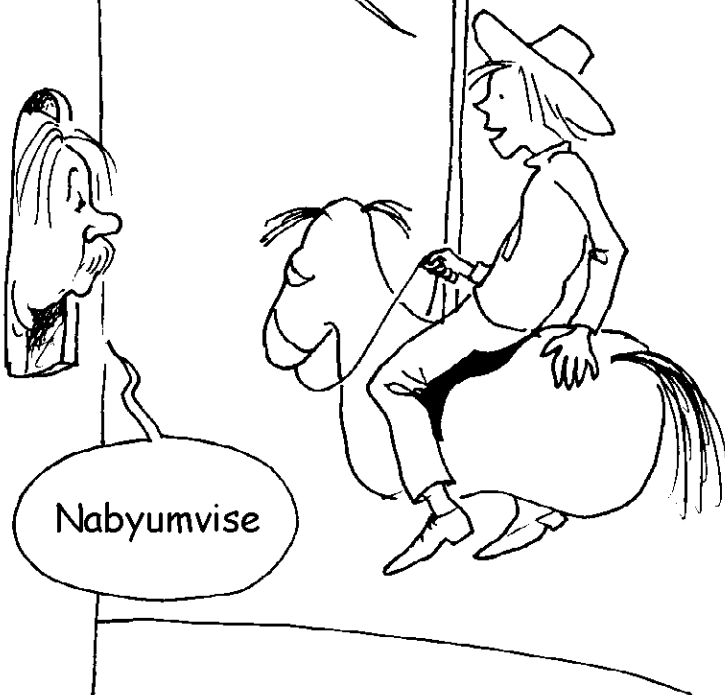
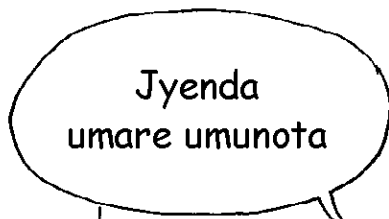
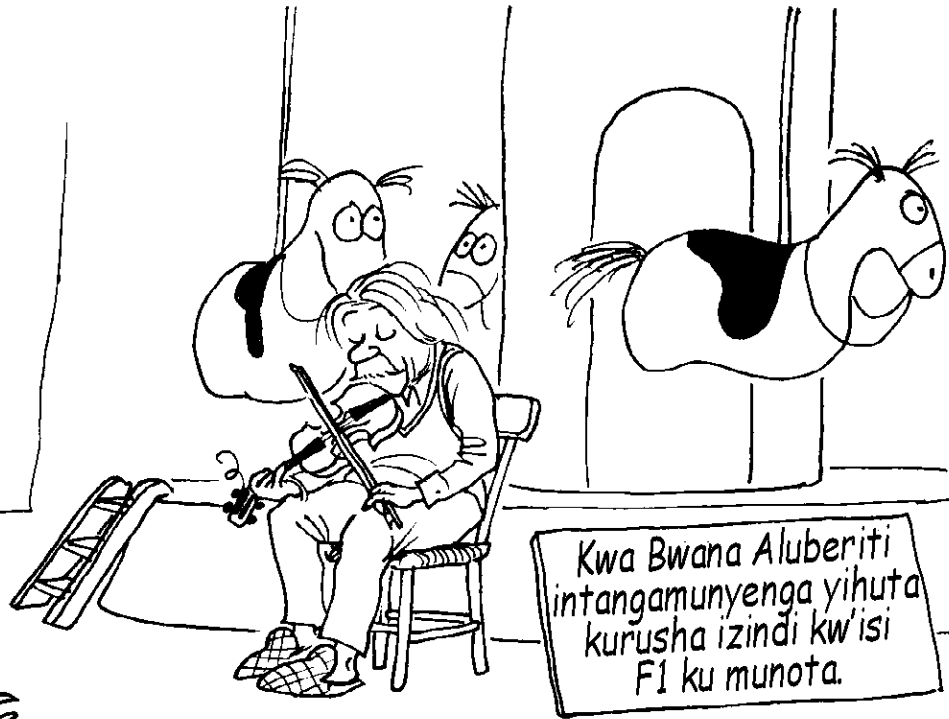



Hageze!

Nonese disi, isaha yawe,
yuzuzamunota mu masegonde
mirongo itanu n'icyenda.



Habe na gato, mfite
umunota wuzuye neza!

kandi ni
koronoperifegita,
ipima igihe mu buryo
bw'igaragaza
riminuje.



Nanjye kandi mfite
koronoperifegita.
Ni amayobera... Isaha nshya!...
Yenda bwaba ari
ubwoko bubi...

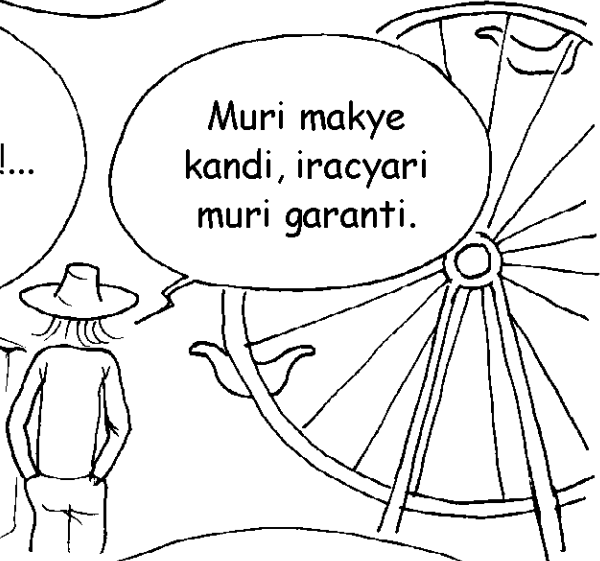

Muri makye
kandi, iracyari
muri garanti.

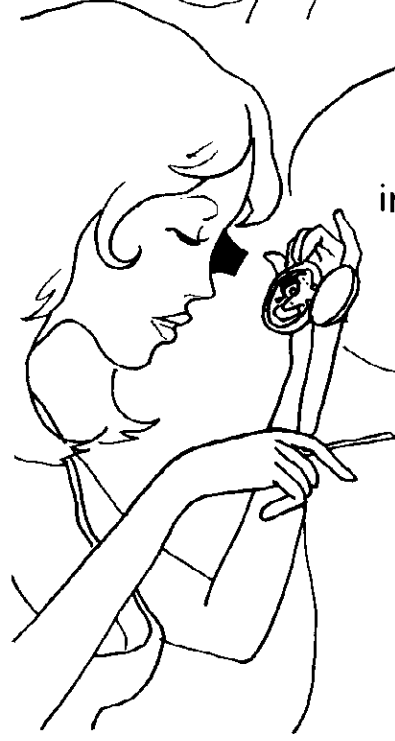

Isaha yawe
irakora neza, Anselimi.
Za koronoperifegita
ni indahindurwa.



Rero, biturutse
ku ntagamunyenga!...

Mbwira, Bwana Alubereti,
birashoboka ko twarebesha
inyuma intangamunyenga ?

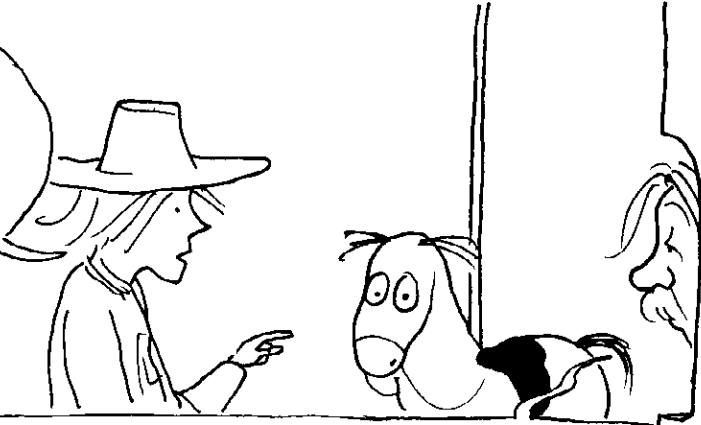

Nta kibazo. Buri gihe ni ifaranga 1 umunota

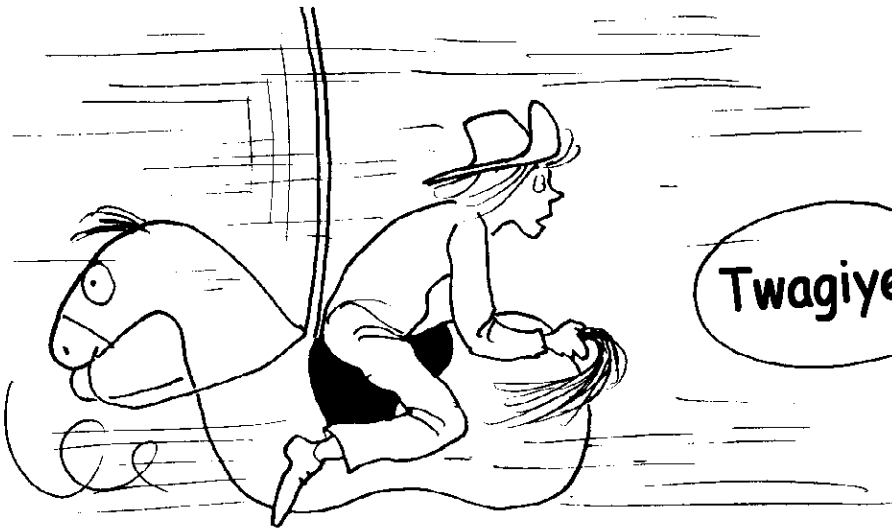

Twagiye!

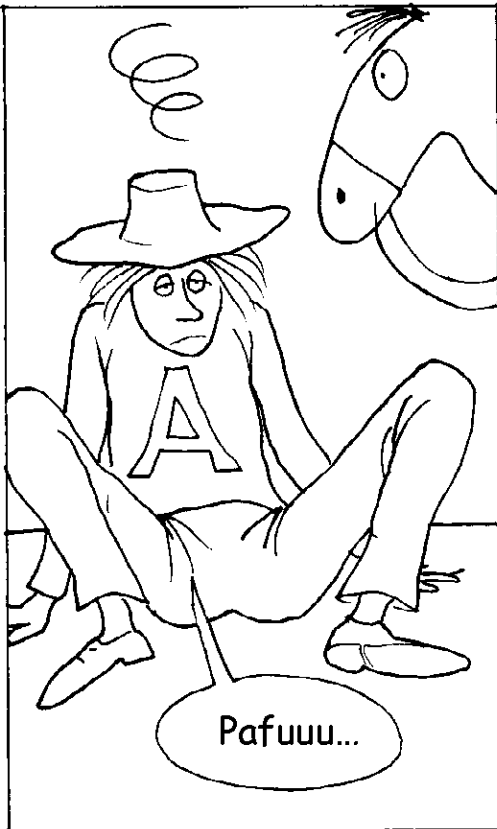

Pafuuu...



muuu...



Hee ?



HAGATI AHO



Muraza ? Tugiye gutembera n'ubwato bugendera munsu y'amazi.

UBUSAZI BWA
BWANA ALUBERITI
KUJYA MU NDIBA
YIBINTU
FI UMUNOTA

Icyo ni igiki ?

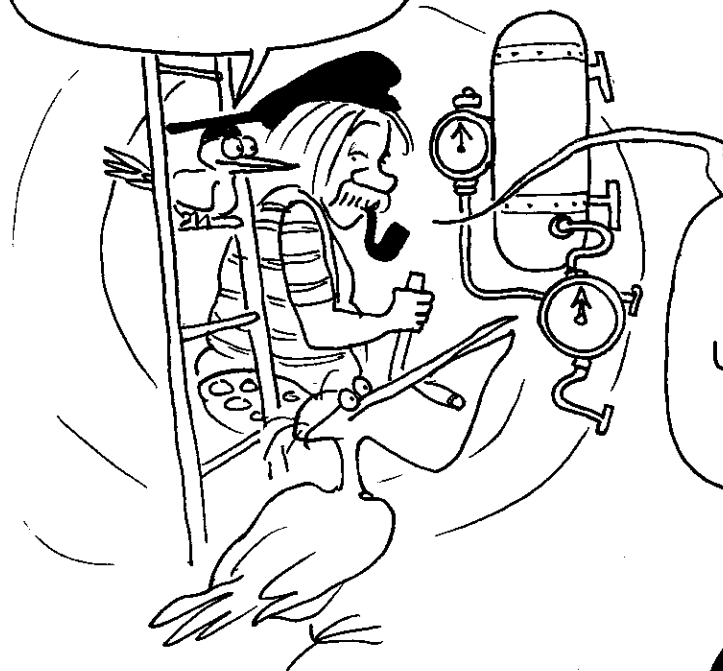

Ni isaha ikoresheya n'amazi. Igitemba, kiri muri rezerivuware, kirengejweho umwuka w'isunika Pr. Uwo mwuka usunika icyo gitemba ukiganisha hanze y'ubwato bugendera mu nsi y'amazi; ugicishije mu gipimo cy'urusuko.

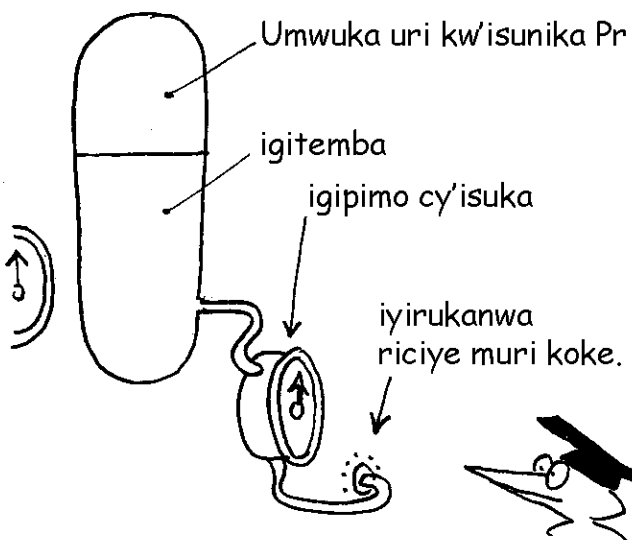

Vuga, kuki igipimo cy'isuka giciyeho uturongo tw'ipimwa mu masogonde?

Ni umwanya uba uhita,
si byo se. Ihame rya kyera
rya Kelepusideri.

Anha yego,
kandi isukwa rigereranijwe
ni igitandukanyo hagati y'isunika
rya rezerivuwari n'isunika
riri hanze.

Ubwato bugendera mu nsi y'amazi
bwa nje bufite amaboko y'ibyuma yo
kwibira akora k'uburyo uko ubwato
bwihuta ari nako bugenda bwika.

Ni ukuvuga ko,
kugirango upime umuvuduko,
hakenewe gusa manometro
ipima isunika ryo hanze.

Birahagiye,
nabyumvise.

Tubwire, ikinyabuzi
cyawe cyirya umwanda
mu kwihuta.

Byiza tuzamuke.
Umunota urasa
n'urangiye.

Ooh, reba,
nti byumvikana ! turi
kw'ipaje ya 25.

TUREKE MAGISI NA LEWO BIREBERE INGARUKA Z'URUJYENDO NSHAKISHA
RWO MUNSI Y'AMAZI RWABO, NONEHO TUGARUKE KURI ANSELIMI



Ni amayobera iyo umuntu abitekereje.
Muri esipase intumbero yose watoranya,
bisa n'ibigaragara ko buri gihe ushobora kugaruka
aho wahoze; ushobora gufata intumbero
ibusanye n'iyambere.

Ukwitingisa
by'ubusa.



Nshobora kwihuta cyane
kurusha tireziyasi, cya gishorobwa
kandi nka nagisiga.

cyangwa se rero nga hagarara,
nkakireka kikansiga.



Ariko iyo
bigeze ku gihe,
byose bisa
n'ibitandukanye.

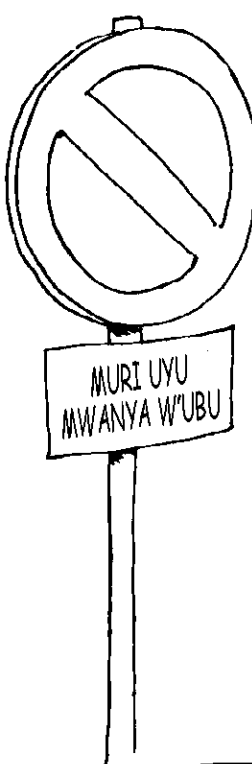

Mu bigaragara,
birabujijwe
kuhahagarara.

Kurenga kuri iryo
bwiriza byatuma uhaburira
ubuzima.

Bwana tireziyasi ?
ngufitiye ubutumwa
bw'umwihariko.

Bwana cyangwa
madamu ?

Nta gaciro
na gato bifite.

Huume...
Ni kalendari.

Urareba Anselimi,
buri gihe uko ukuyemwo
urupapuro, umunsi urarenga.

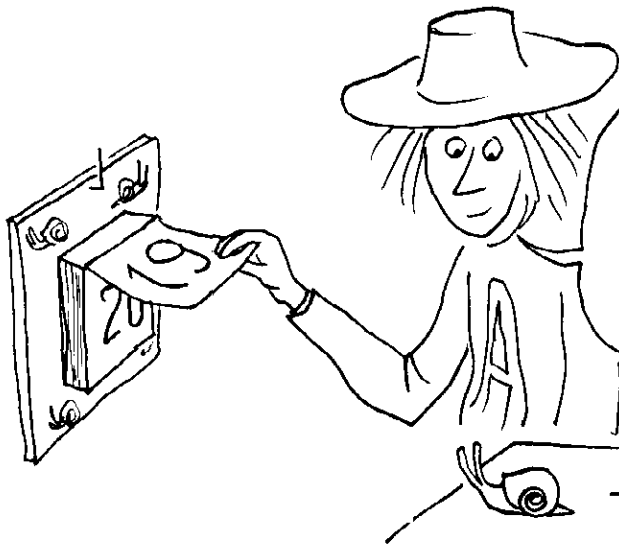

Oya ariko, Tireziyasi,
ntidushobora guhindura ihita ry'igihe.
Kugirango ukuremwo urwo rupapuro,
ugomba gutegereza ejo hakagera.

Aha...

ESIPASE GIHE



Sofiya,
ese ubundi igihe
ni iki ?

Ni dimansiyo nk'izindi.
Jya kuri balanswari,
ndaje ngusobanurire.

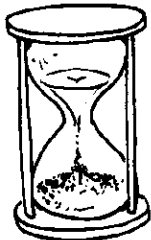

Bagiye gushakisha
nka byabindi !



Urareba, nk'urugero, kuki igihe kigana imbere gusa kandi ariko ntikigane inyuma ?

Ba uretse, ngufilime.

None se ?

Mperezamukasi.

By'ukuri afite
amaso abengerana.

Buri shusho y'iyi filime ni igicapo gisa
n'igihagaritse **UMWANYA WAKO KANYA**.
Buri seconde y'iyi filime igizwe n'amashusho 24.
Biboneka ko igizwe n'urukurikirane
rw'ibyabaye bidafatanye.

Ubu ngiye
kukwerekana ikintu
kimwe: rundarunda urwo
rukurikirane
rw'amashusho,
rw'ibyabaye.

Uboneye
esipase-gihe.

Esipase-gihe ?

Iyaba nari nongereye umubare
w'amashusho kugera ibudahera,
nari kubona esipase gihe
ifatanye ya dimansiyo eshatu.

Ebyiri za esipase
n'imwe y'igihe.

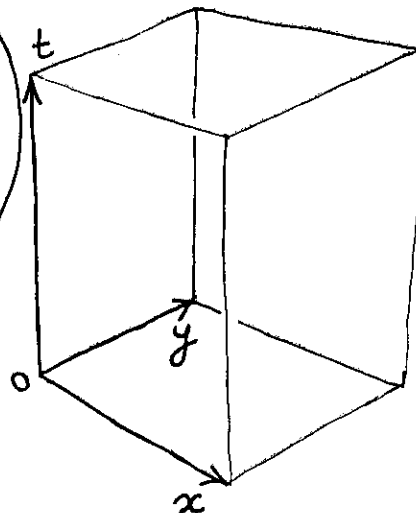
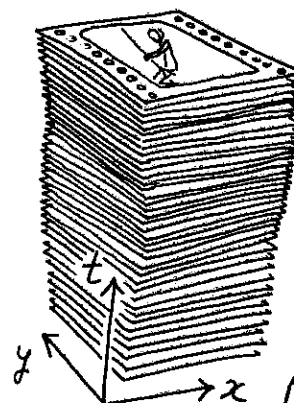



Tubibutse ko umubare wa dimansiyo ya esipase ari umubare usanzwe w'intumbero zihagije ngo ugaragaze, werekane ikicarwo cy'AKADOMO k'iywo esipase.

Dutuye muri esipase-gihe ya dimansiyo ENNYE. Ubirebye hakenewe ibibarwa bine, ibiranga bine kugiranga ihuriro ribere mu kadomo kamwe k'iyi esipase-gihe.

Tirezziyasi yampaye randevu kuri nimerwo CUMI N'EBYIRI z'umuhanda wa KANE, kuri etaje ya GATATU. Ariko, kiriya gicucu, kibagiwe kumbwira neza isaha. Ubu mfite gusa ibiranga bitatu !



Ariko, kugirango dushobore gushushanya neza, tugaruke kuri za esipase-gihe za dimansiyo eshatu (ebyiri za esipase, imwe y'igihe)

Nshuti yanjye, waruzi ko, tugendera mu gihe ?

Ariko... ntituva aho turi !

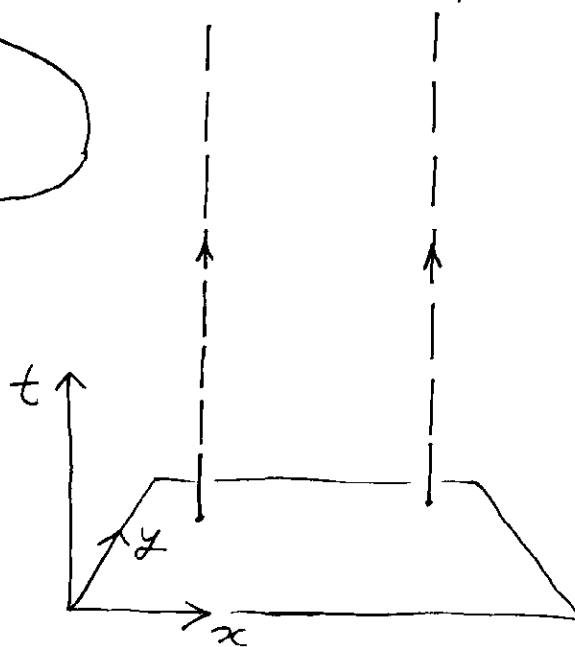
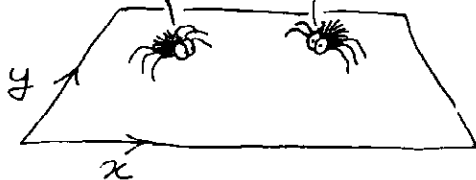

Urugendo rw'ibitagangurirwa bibiri muri esipase-gihe yerekanwe ku gishushanyo k'iburyo.

Urugero, iyo ngendagenda nkurikiranye serikeri, inzira ya nje, muri iyo esipase-gihe ya dimansiyo eshatu, izagira iforoma ya rosoru ya budine.

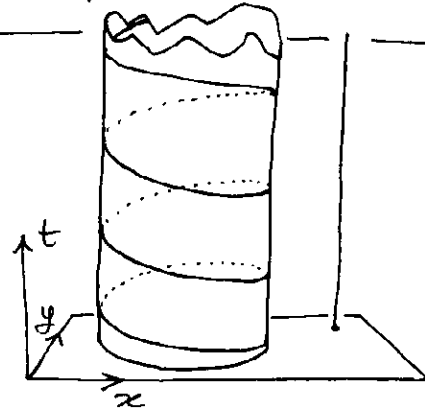
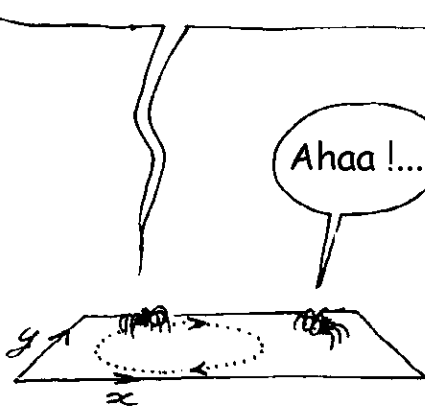

Muri make, UBU NYAYO ni umuzingi ubyataraye ukorewe muri iyo esipase-gihe.

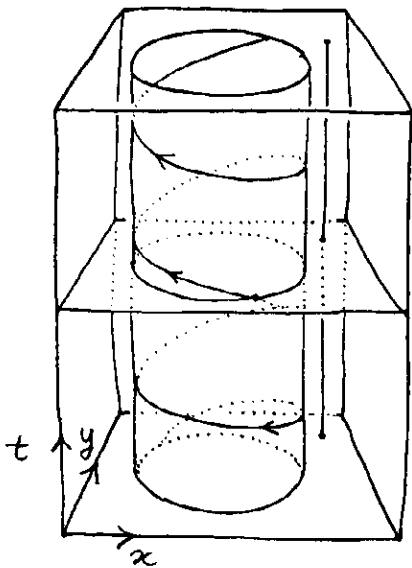

Ibiri hejuru byitwa AHAZAZA.
Ibiri mu nsi byitwa AHAHISE.

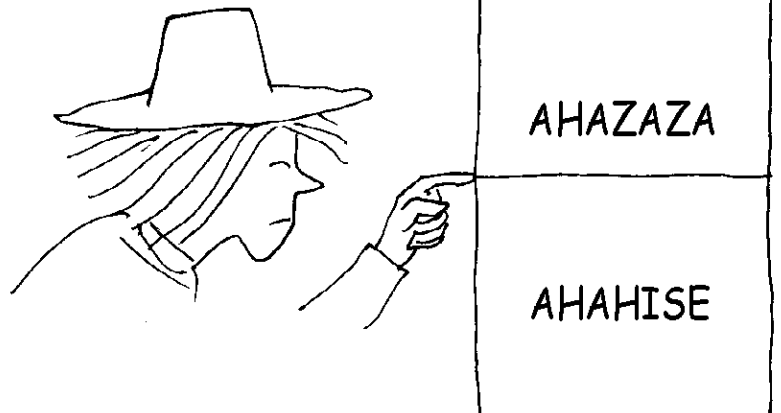
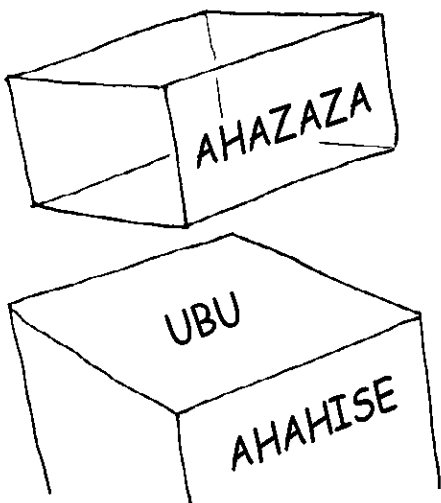

Arisitote ni we watanze igitekerezo ubwambere ko UMWANYA W'UBU ugomba kugira umubyimba ungana n'ubusa.

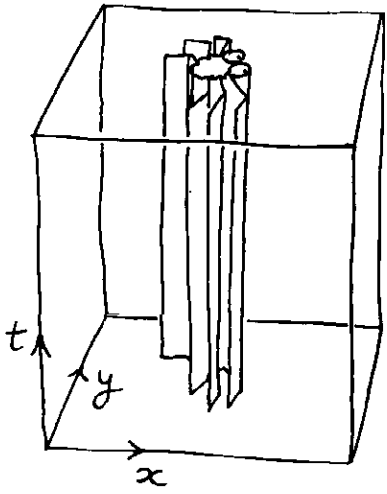

Mu by'ukuri, ni uku twagombye kwerekana igitagangurirwa muri ya esipase-gihe ya dimansiyo eshatu.

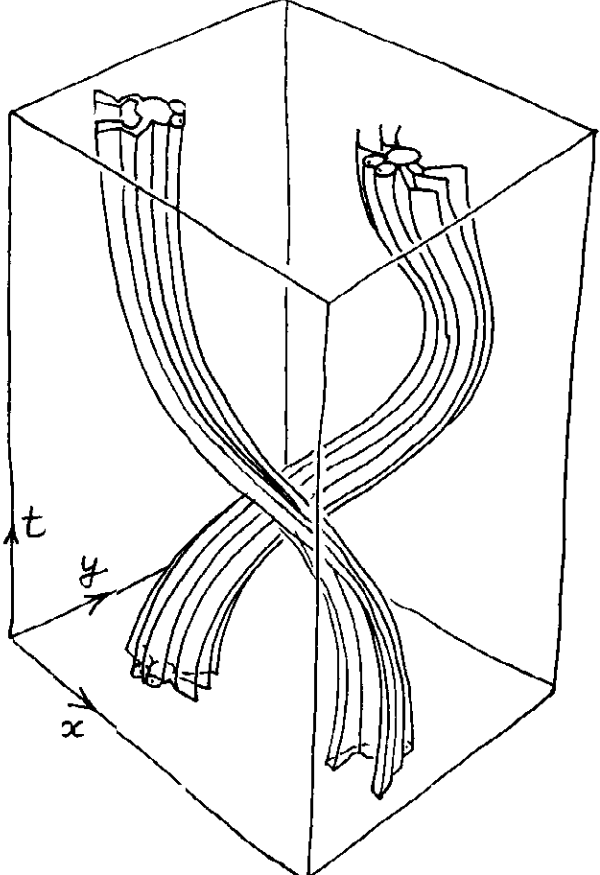

Kubaho kw'igitagangurirwa gushingiye mu kutagira ihuriro, muri esipase-gihe, y'inzira ya cyo n'iy'igikeri.



Ariko se kuki tutabona ayo mahuriro y'izo nzira muri esipase-gihe ?



Ihuriro ry'igihe gito muri esipase-gihe

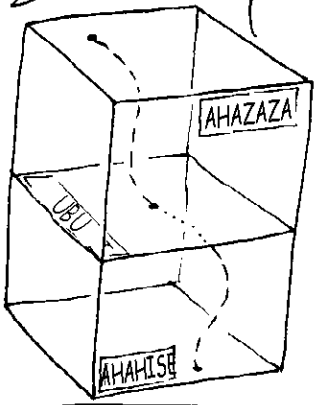

Kuko gusa tubona UMWANYA W'UBU.

Mu nzamura y'igihe, twese ntakabuza tuyirimwo.
Ntihagarara cyangwa ngo imanuke.

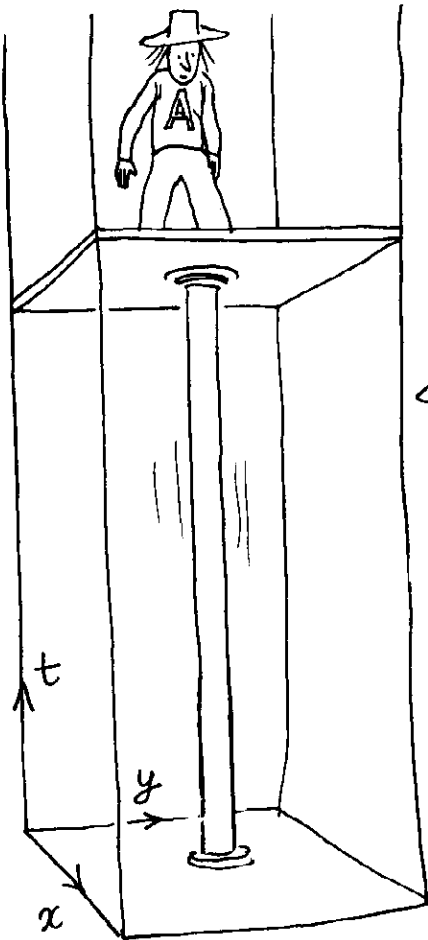

Ku wambere - Ku wakabiri - Ku wagaratu - Ku wakane - Ku wagarari - Ku wagarandatu - Ku cyumweru

Inzamura
itagira urugi...

... itagira aho
ukanda... mbega
agahinda...

Ibya amahirwe
hari Sofiya



Sofiya, reba, nakase impetame
muri esipase-gihe !

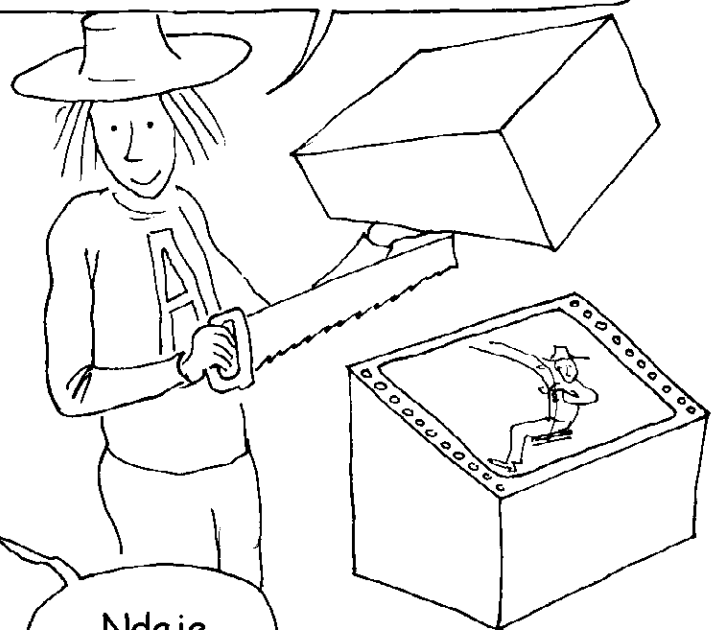

Ndaje.



Ako ni akantu
gakunzwe gukoreshwa
mu bishushanyo
ntizwabuzima.

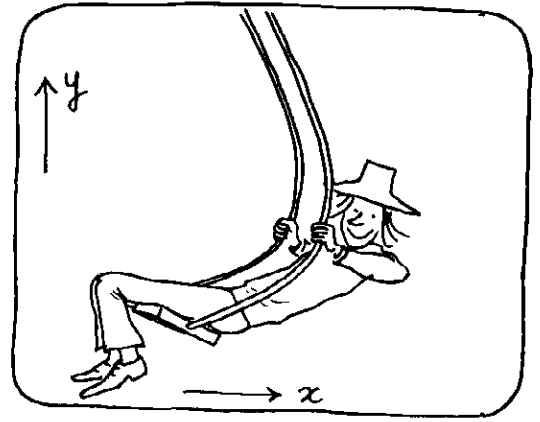

UMUTEMERi W'URUMURI

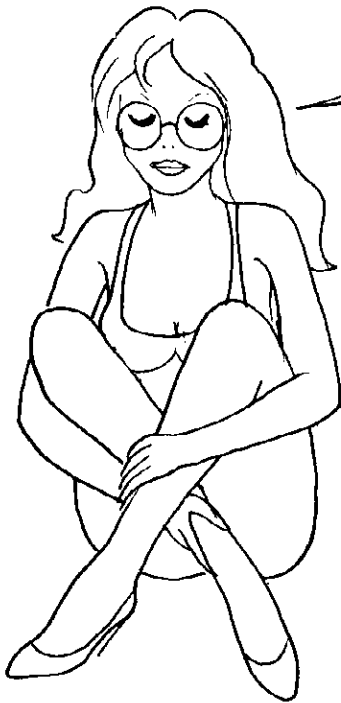

Mu by'ukuri tureba bihetamye ku biriho



Aho
ushatse
kuvuga iki ?

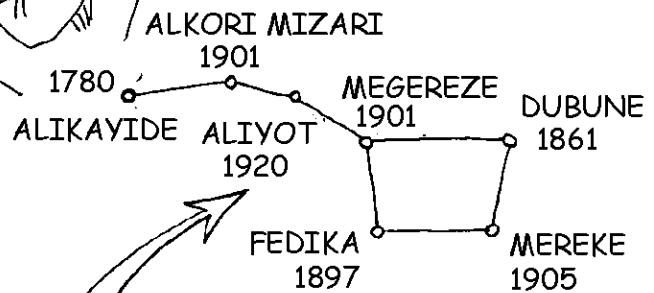

Urumuri rukoresha umwanya ngo rutugereho
ruturutse ku bindi bintu. Aha ngaha, twerekanye
igihe rwohererejwe ruturutse kuri buri nyenyeri ituye
mw'ikoraniro ryitwa Uruse Nini.



Muri make, inyenyeri duturanye zishobora kuba rwose zarayonze kandi nkazabimenya hashize imyaka !

Ntabwo amakuru yose atugeraho vuba

Twakira ku masahane ya za telesikope ishusho y'Andoromede nk'uko yarimeze mbere y'imyaka miliyoni ebyiri.



Tubona izuba nk'uko ryari rimeze mbere y'iminota munani

Kandi ibirenge byanjye birashaje kurusha izuru ryanjye !

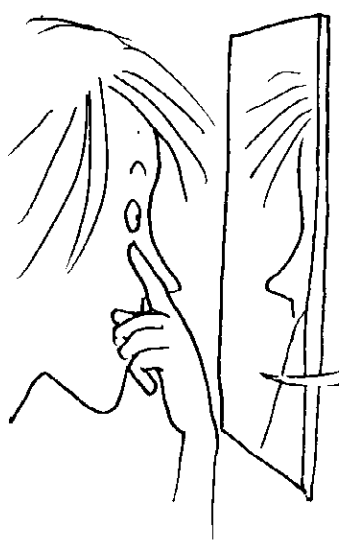

Muri macye, ntakiruhije kubona nk'UBU. Yenda nk'ikintu cyo cyugarije imbone ?...

Oya, Anselimi, dushobora kubona gusa ibyo mu gihe cyahise. Iryo bona ryitwa UBU BUGERERANIJWE; mu kanya gashize twavugaga UBU HIHARIYE. Ubu ni ikintu kiyanye gusa na nyiracyo, ntigisangirwa.



Imiraba yikwirakwiza ku mazi n'umuvuduko udahinduka. Hano, twerekanye igitagangurirwa cyaguye mu mazi cyirihwo cyohereza imiraba ihuje santeri.

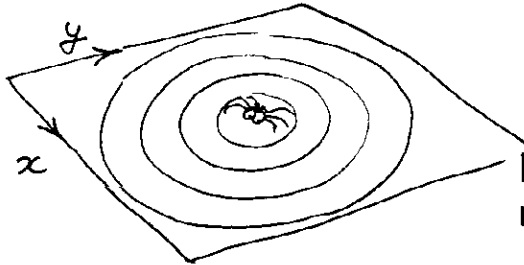

Muri espase-gihe, ubwo butumwa busakara bukurikije umutemeri.

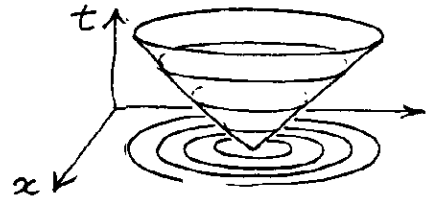

Ni cyo kimwe neza nk'urumuri, rukwiragira n'umuvuduko udahinduka wa km 300 000 km/s.

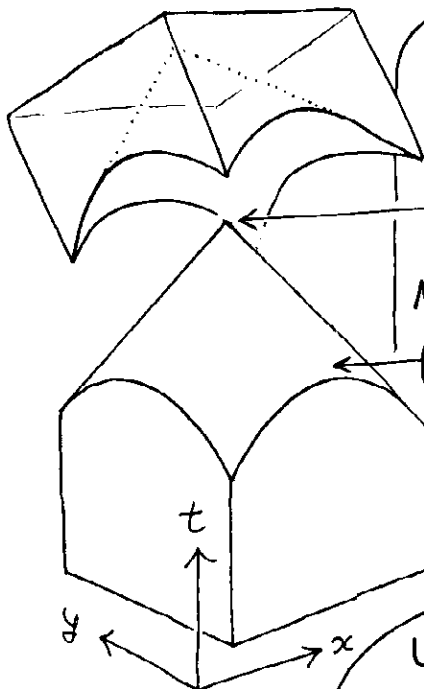

Dukurikije inzira icuritse, ibishashi by'urumuri byakirwa buri kanya

n' **INDOREREZI** bituruka k'utudomo dutuye ku **MUTEMERI** wa espase-gihe:

UMUTEMERI W'URUMURI

Uwo mutemeri niwo **MWANYA W'UBU UGERERANIJWE** w'iyi **NDOREREZI**.

Ni ukuvuga ko
Ijuru ari umutemeri ?

Yego, Anselimi, ni igice cya kone cya dimansiyo eshatu, cyakaswe muri espase-gihe ya dimansiyo ennye.



Umutemeri wa dimansiyo eshatu ?...

Hum...

Intekerezo ubwonko bw'umuntu butateguwe neza kwakira. Tubona kandi du TEKEREZA muri dimansiyo eshatu, ntabwo ari muri 4. Bityo noneho reka, tugaruke vuba na vuba kw'ishusho yacu ya esipase-gihe ya dimansiyo eshatu.

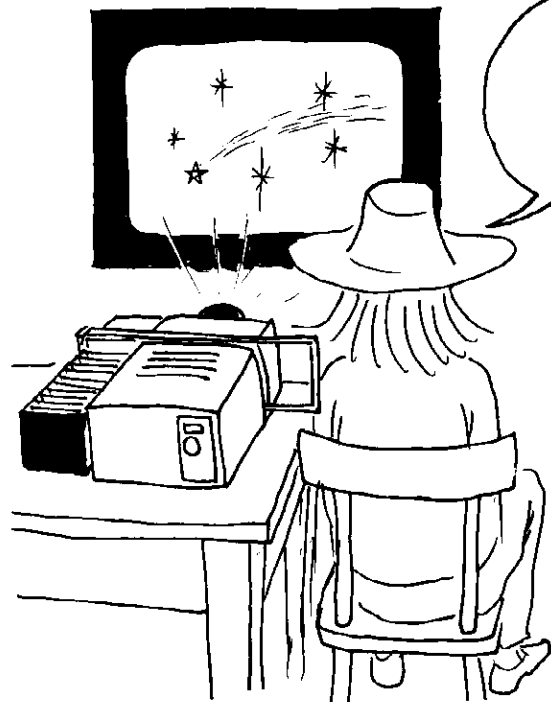

Ni byiza kwigereza esipase-gihe. Ariko, kugirango bikorwe neza, umuntu agomba gukoresha insigariramafoto z'umutemeri, inyemezabuvumbuzi ya Lanturulu



Ariko se mu byukuri, Lewo na Magisi bariho barakora iki ? Dore hahise amapaje cumi n'atanu bazimiye.

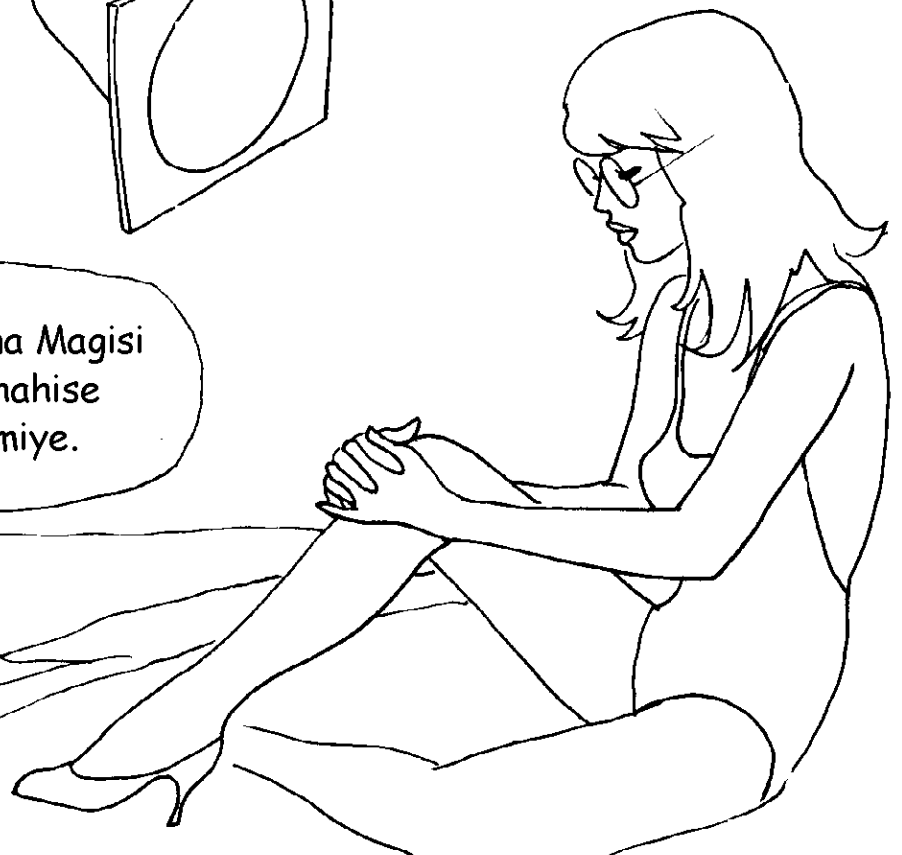
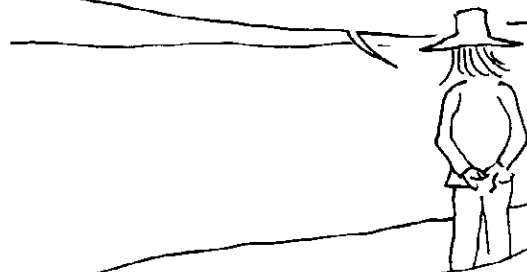

Nababonye mu mwanya ushize
binjira mu bwato bugendera mu nsi y'amazi
bagiye kwibira bimara umunota. Ariko hashize
igihe kinini kiruto icyo kuva aho bagendeye !



Ahaa, dore ngabariya barazamutse.
Bakoresheje igihe kirekire !

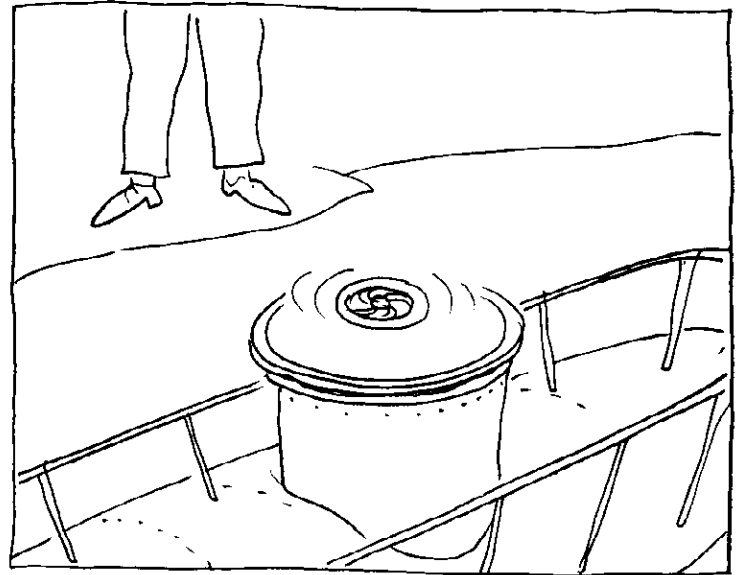

Ohu, reba,
ntawabyemera !
turi kuri paje ya 25.

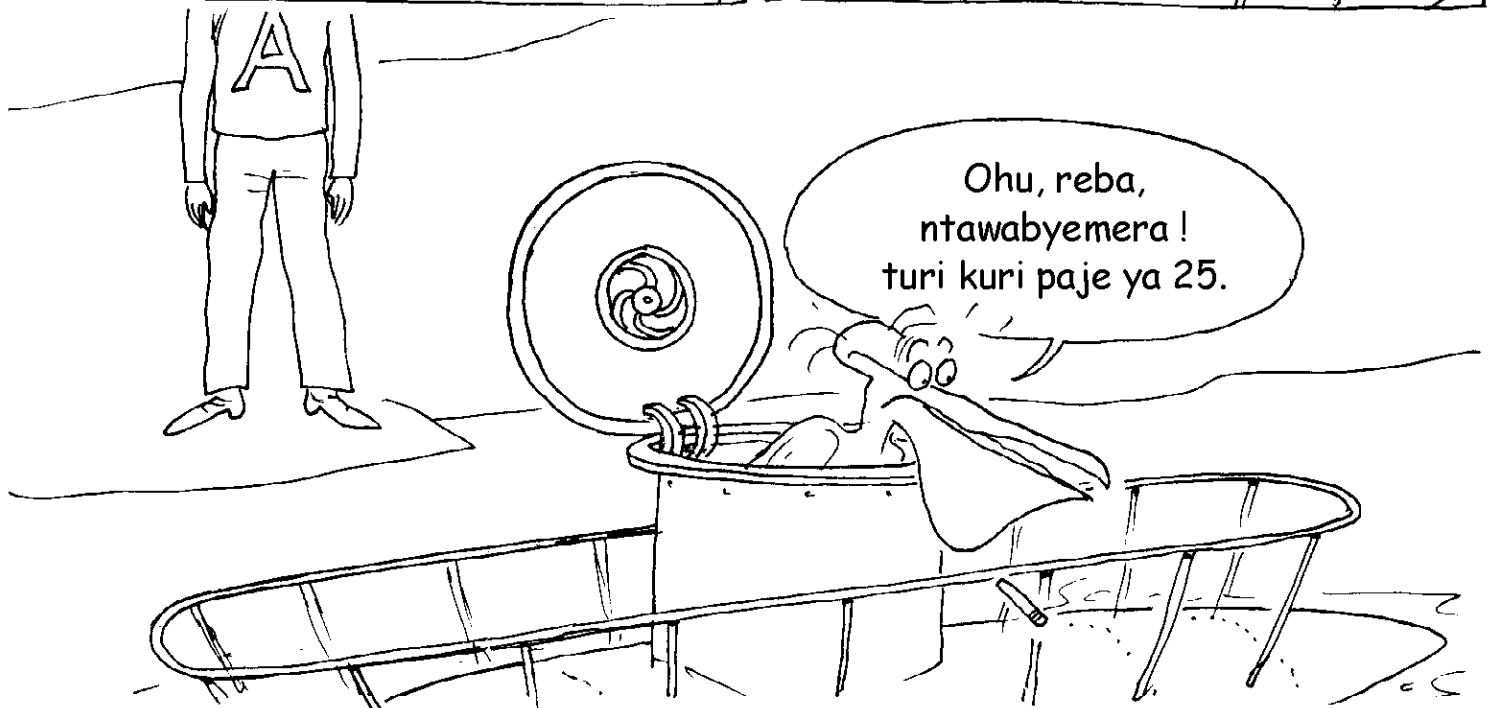



Kandi noneho reba, umunota umwe utarenga !

IBIKI !?!

Ni nko mukanya kuri ya ntangamunyenga.

Igihe, Anselimi, ntabwo ari ikintu KIMINUJE.

Dore ikindi kintu !?!

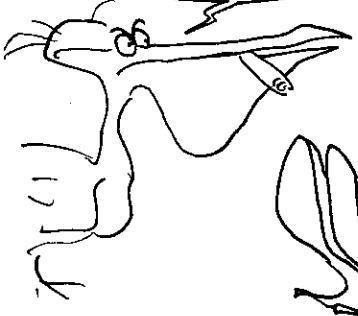

Anselimi, uriya mwana w'umukobwa afite ukuri. Uko wihuta cyane, niko usaza gacye.

Abantu bavuga ngo: kugenda ni ugupfa buhoro buhoro. Noneho rero byaba bicuritse !?!



Mube muretse,
kelebuside ya Bwana Aluberiti, cya kinyagwa
cyo mu mazi, cyatangaga RWOSE igihe
cyahise muri mu bwato bugendera
munsi y'amazi ?



Urtyo ! nk'uko nabibabwiye,
iriyi kelebusideri igaburirwa na
reserivuwari y'isunika ridahiduka Pr.
Itangirira hanze y'ubwato bugendera
munsi y'amazi ahari isunika Pe.
Isukwa rihinduka mu buryo bumwe
n'igitandukanyo k'isunika (Pr-Pe)



Uko ubwato bugendera munsi
y'amazi bwihuse ni nako isunika Pe
ryiyongera, ni nako kelebusideri
irekura amazi make. Birtyo rero,
uko wihuta cyane ni nako igihe
kigenda kigabanya kwirekura.



Mube muretse ! izo nkuru ni nyabaki ?
Ese igihe cyirekura gite iyo umuntu agumwe hamwe ?

Kuguma hamwe
ugereranije n'iki !?!

Ni itangiriro rya kelepusideri mutangabuhamya
yashyizwe mu bwato bugendera muni y'amazi,
bwo ahubwo, buguma ku nkombe, buhagaze aho,
bityo buguma hejuru y'amazi.

Ngiye kubigaragaza neza !

Kuguma ahuri
utanyeganyega
bivuze iki ?

Sofiya, urafata nimeru ya 2, jyewe nimeru ya 1.
Nimeru ya 3 iraguma mu nzu, hanyuma twese tuzagera
mu mazi ku muvuduko umwe V

Noneho se
kugenda byo !?!

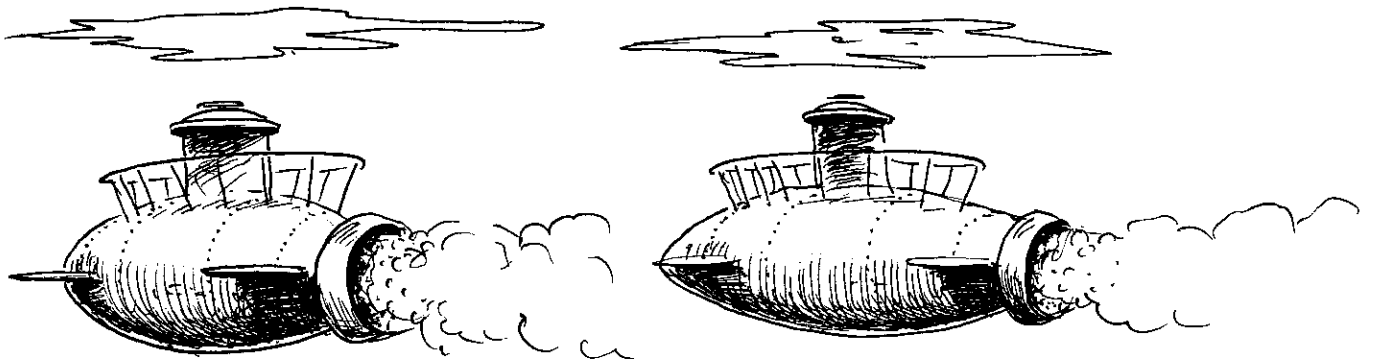

Bagendera hamwe: umuvuduko umwe V,
intumbero imwe n'uburebure bw'epfo mu mazi bumwe.



Iyo ukora amageza, ni uko uba
utizeye neza ibyo uhagazeho.

Cyo nyibwirira neza,
Bwana Aluberiti, urugendo ni iki ?



BULEBE
BULEBE BULEBE



Tireziyasi, icyo ni ikibazo cyiza.
Ikiriho ni IMIVUDUKO NJYERERANYI
y'ibintu utangiriye ku bindi. Noneho rero
iyo twemeje ko ikintu, cyangwa agatsiko
k'ibintu : jyewe, wowe, inzu, turi hamwe
tutanyeganyega, ni imvugo idafite ishingiro.
Urugendo rwose ni NGYERERANYI.

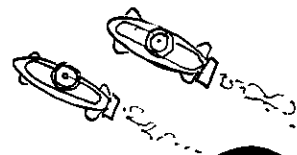

Dore turahari twagarutse aho twatangiriye, kandi kelepusideri zacu zarekuye igipimo cy'amazi amwe, zitanga igihe kimwe t'.

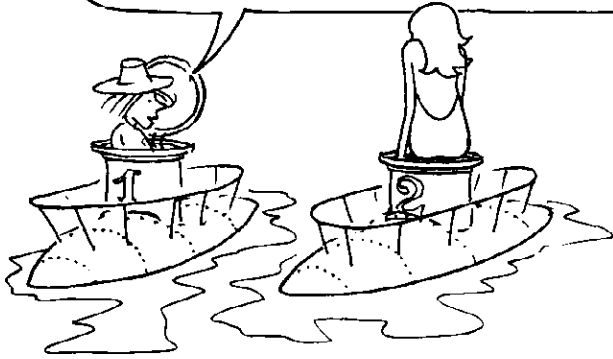

Sisiteme ebyiri ziri hamwe zitanyeganyega imwe igereranijwe n'indi ziba ari SENKORONE.

Ariko si kimwe na kelepusideri ntangabuhamya, yayindi ya nimeru ya 3, yasigaye hamwe, itanyeganyega, ni ukuvuga hejuru y'amazi. Yo, yerekana igice cy'igihe t kirekire gusumbaho.

Mutegereze, Bwana Aluberiti, hari ikintu kitagenda neza mu bintu byanyu.

Humu....

Iki, mwana wa ?

Muhereye hejuru y'amazi, mwashoboye gupima urugendo rwacu D, hamwe n'igihe twamaze twibize t ukoresheje kelepusideri y'ubwato bugendera munsu y'amazi nimeru 3. Ibyo byatumye tubona umuvuduko $V = D/t$.

Ni ibipimo byakozwe n'ingenzuzi iri hamwe.

Mu bwato bugendera munsi y'amazi nimeru 1 na 2, ibihe bihita, byisuka buhoro buhoro. Iyaba twari twakoze igipimo cy'umuvuduko, twari kuba twabonye umuvuduko $V' = D/t'$ munini kuruta $V = D/t$

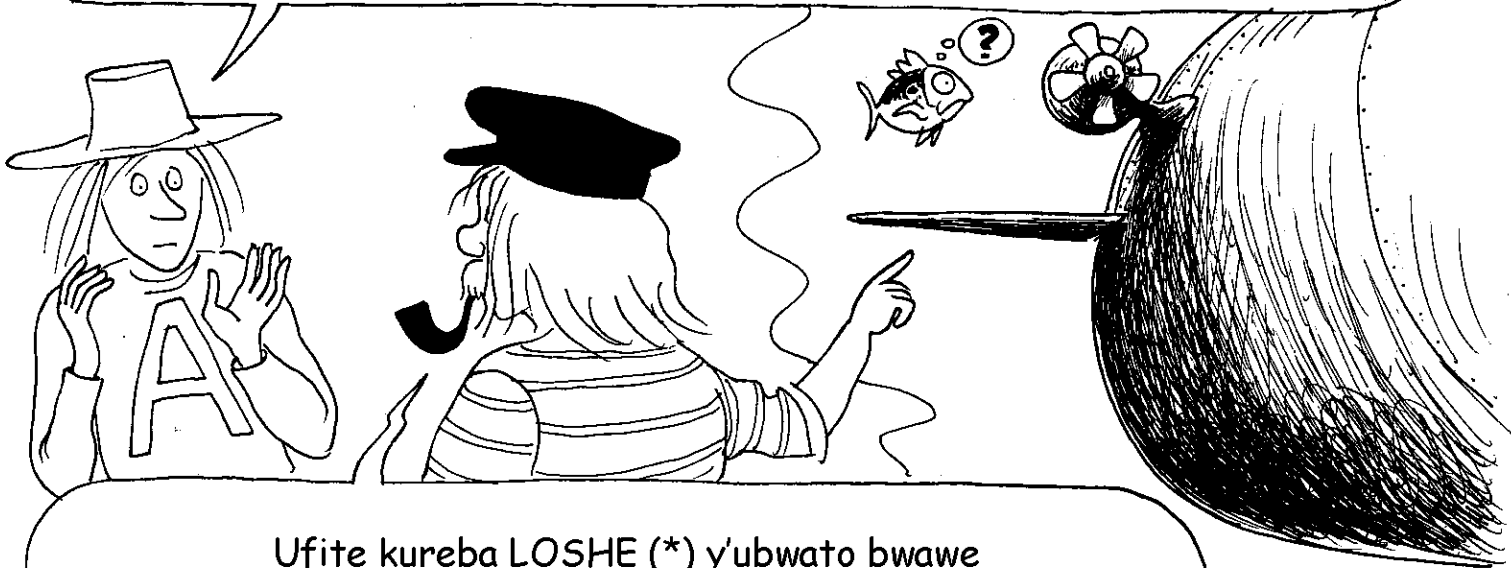

Ufite kureba LOSHE (*) y'ubwato bwawe bugendera munzi y'amazi. Bizaguha igipimo cy'uburebure D' by'urugendo wakoze.

Ibyo nabyo rero !?!
 $D' < D$

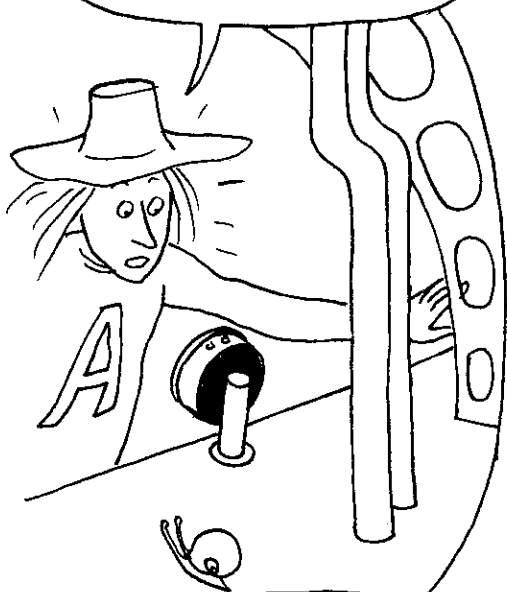

Biragenda bisa
n'inkuru y'abasazi !!!

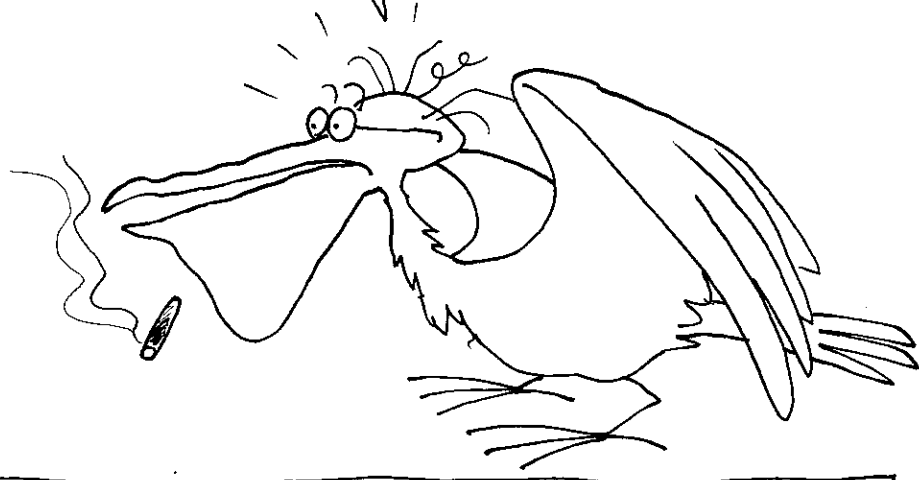

(*) LOSHE ni igikoresho cyo kugendera mu mazi kiguha igipimo cy'urugendo wakoze.

UKWIGEGERANYA K'UBUREBURE



D/t = D'/t'
ndabona umuvuduko
umwe V!

Ariko !... bivuze ko
esipase yiyegeranije
nk'akoridewo,
si byo !?!

Igihe, uburebure,
ni UBWIGARAGAZI gusa.
Ni nk'uko nta GIHE CY'UMWIHARIKO
UMINUJE cyangwa ESIPASE
Y'UMWIHARIKO UMINUJE
bibaho.



Agahinda...



Ariko tugaruke kuri
PIRIKYE KOSIMIKYE no ku Nyanja yayo,
KORONOSI, biri gusa nk'AMAMODELI,
bigenewe kugaragaza imiterere itangaje
ya esipase-gihe yacu.

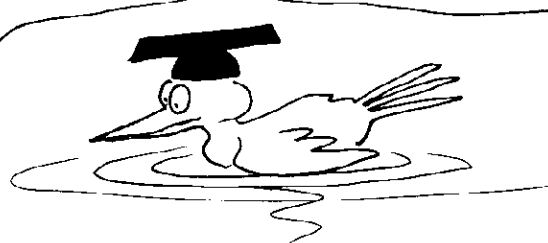

Kugirango nguhe igishushanyo cy'urugero ry'iryo yegeranyo ry'uburebure, cyangwa IYEGERANYO RYA LORENTZI, PALIKYE KOSIMIKE igomba kuba nk'ubwoko bwa siferi buzi.

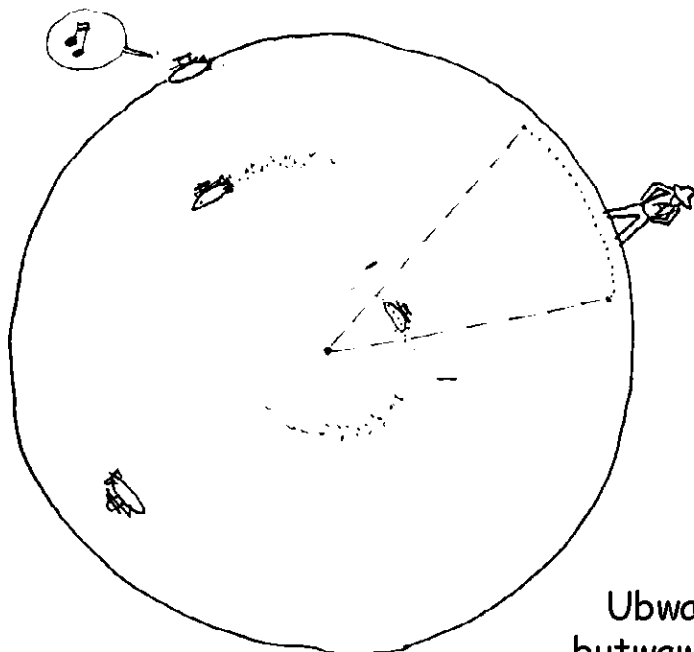

Ubwato bugendera muni y'amanzi bwa Anselimi, butwawe n'umuvuduko V , bugenda bwibize, kandi bugendera ku gice cy'umuzingi $A'B' = D'$ mu GIHE NYACYO, gipimiwe ku nkombe, ungana na t' .

Ku ndorerezi yashyizwe hanze, ku mazi, urwo rugendo rugaragaye nk'igice cy'umuzingi $AB = D$, muri icyo gihe t . Noneho dufite:

$$D'/t' = D/t = V$$

Ni ibitumvikana, ukurikije urwo rugero, urugendo ni NYAMFURUKA ariko ni IMIREBERE gusa ihindura ibyo ngibyo m'UBUREBURE.



Ariko se kuki mwatekereje ikintu gikomeye kuriya ? ibi bihe biruhanya, uburebure bwiyegeeranya !!!

Ni ukubera umuvuduko w'urumuri, muhungu wanjye. Uzareba kure cyane.

Ndibaza ko rero ibintu byose bizahinduka...urumuri ?

Byiza, ibyo byose ni byiza pe, izo nkuru z'igitonyanga cy'amazi, z'ubwato bugendera muni y'amazi, ry'iyegeranya ry'uburebure. Ariko se mu buryo bufatika, byigaragaza bite ?

Subira kuri kiriya kintu, mushakashatsi mu njyendo zo mu mutima wanjye !

Ndi teguye...

Ugiye kubona icyo ugiye kubona

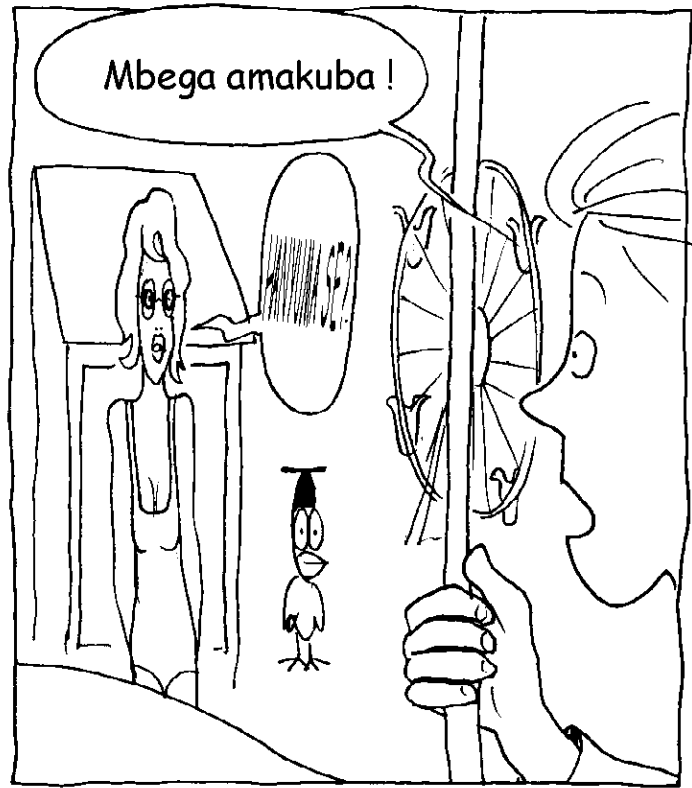
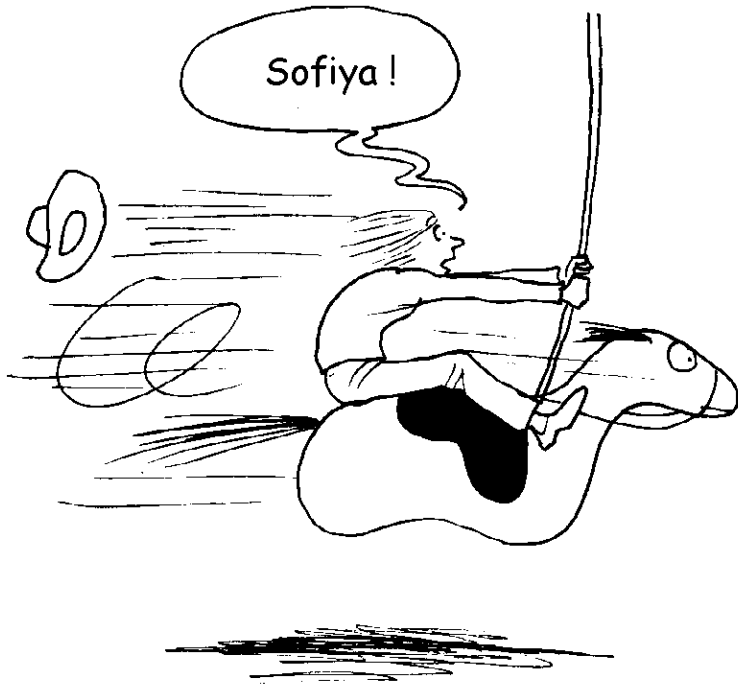

Nshuti yanjye,
tujyende, humura,
subiza umutima
hamwe, byarangiye...

Fisikye ni
igitangaza.

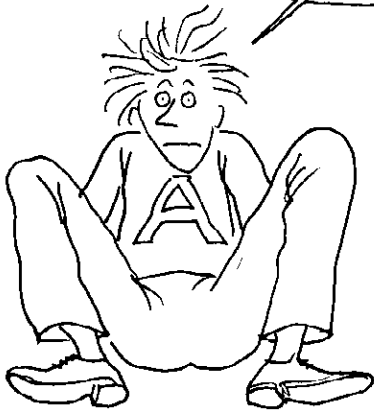

Amahirwe yacu ni uko ziriya fenomene
ziza iyo umuvuduko w'umuntu cyangwa w'ikintu
ujya kungana n'umuvuduko w'urumuri
wo ungana na km 300 000/s

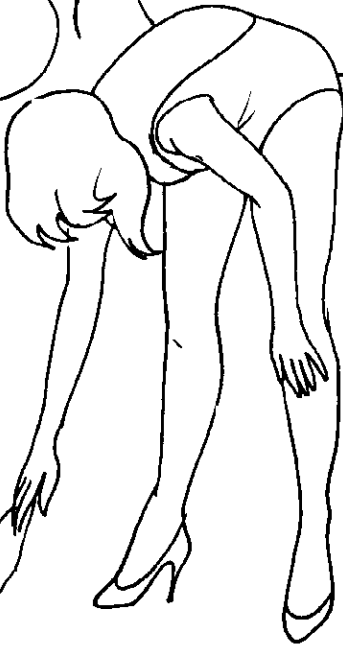

Iyaba uwo muvuduko w'urumuri wanganaga
n'imetero nka zingaha mw'iseconde, ubuzima
bwaba butagishobotse n'agato... He he he !...

Iyo abakosimonote bagumye amezi atandatu ku murongo w'umuzingi w'urujyendo rwabo, ni ukuvuga amasegonde miliyoni cumi n'eshanu...

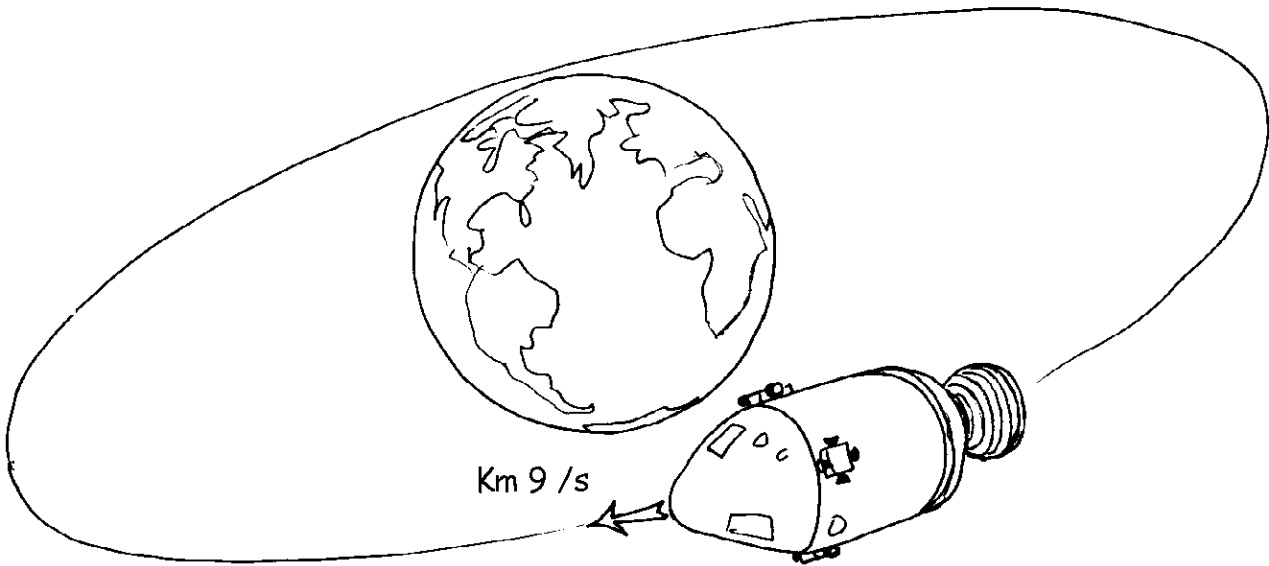

gusaza kwa bo kugabanuka 1,4 kw'ijana by'isegonde.

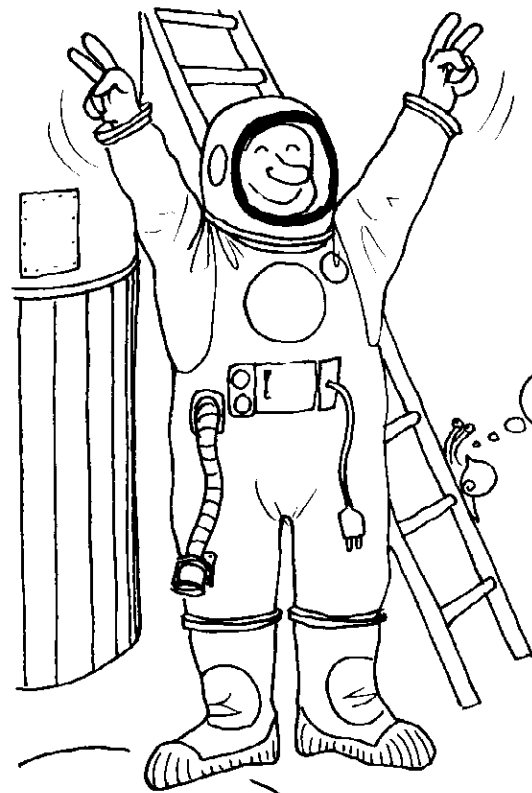

Urugendo nshakisha...

Igihe bagarutse, ntibiba byanditse mu maso yabo.

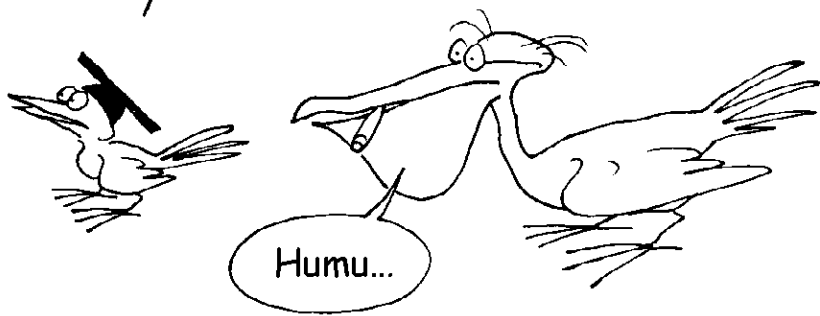

Humu...



Isi ya relativite itugaragarira nk'itandukanye cyane n'ubusima bwacu bwa buri muni.

Muri iki gihe yitaweho n'inzobere za fizikye y'ingufu nyinshi zo mu rwego rwo hejuru (*)



Cyangwa abantu bamwe bakunda cyane amajyeza akorerwa hanze ku mugaragaro.

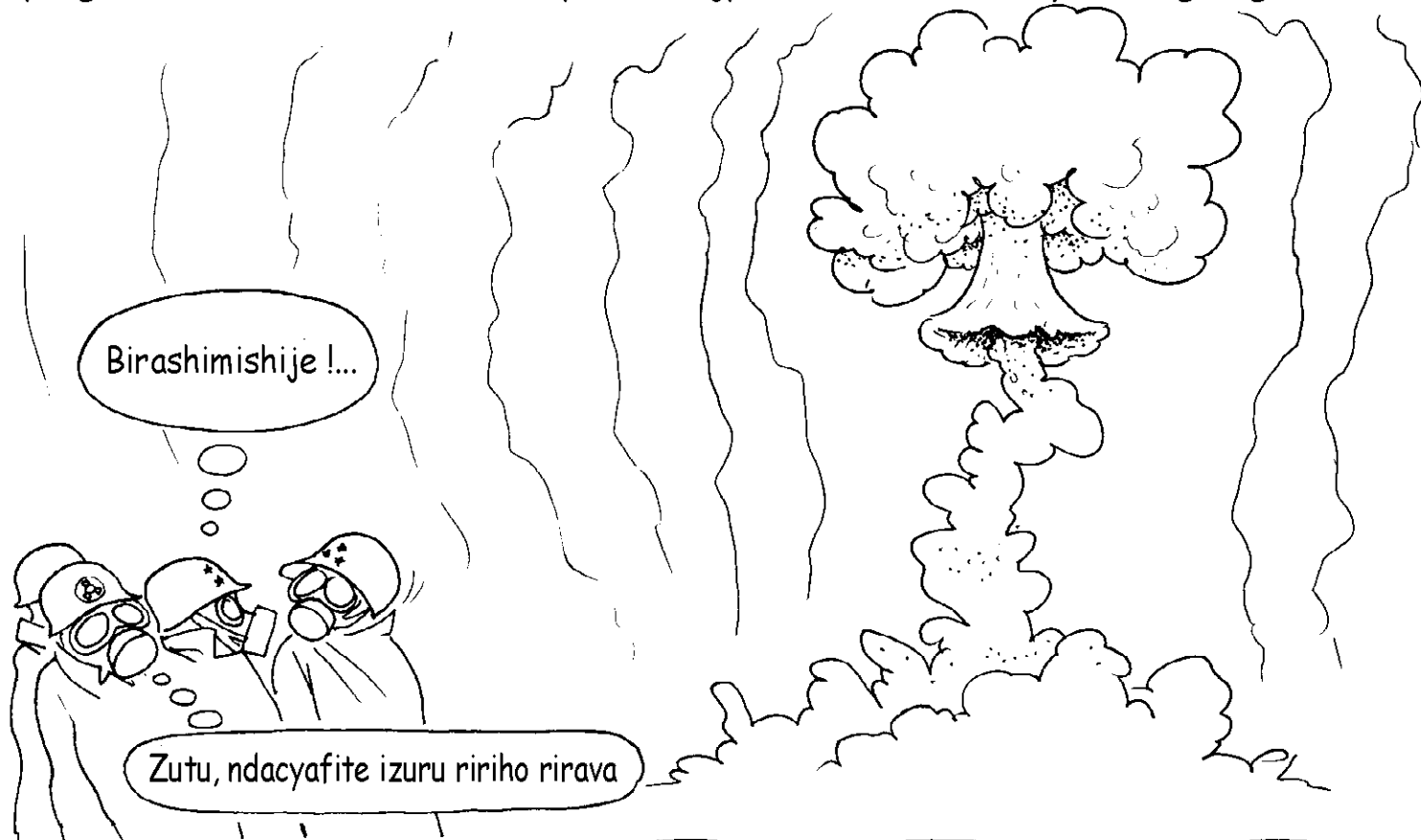

(*) yitwa kandi PULU TOFIZIKYE kuko ari fizikye ihenze...

Iyo nongereye umuvuduko wanjye, ese ubwo
Iniveri iriyegeranya koko !!?

Ibinyabasazi !...

BANZAYI !

kiranwa cyane ?
ibilometero ibihumbi cumi
kw'isegonde. Umuzenguruko
wose hanze mu muyaga
usanzwe. Nongereye
umuvuduko !...



Itangazo ry'akazi:

UBWIYEGERANYE BWA LORENTZI, kubera impamvu nyakuri yemezako BURI KINTU CYOSE KIYEGERANYA :Iniveri, Anselimi n'ikigendajuru cye !

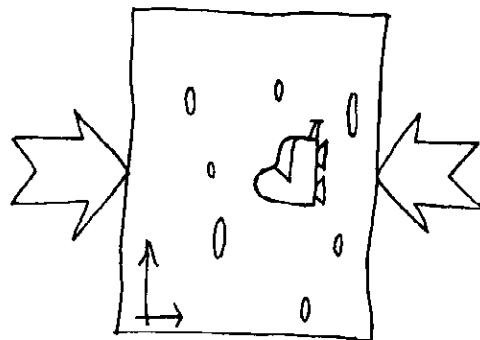
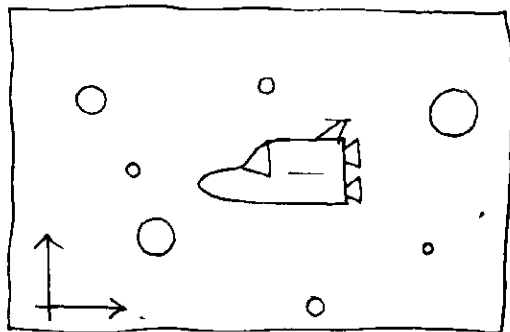

BIRTYO, abagenzi b'ubwato bugendera mu mazi bwa Parikye Kosimikye nti babona ubwihine bwa bwo.

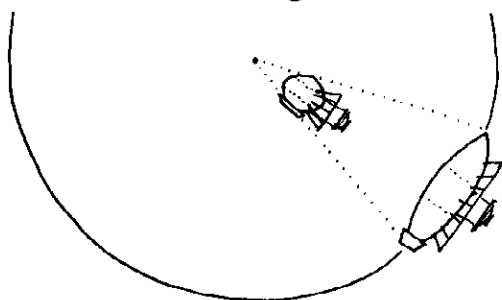

Ubuyobozi

Birtyo, iyo nongereye umuvuduko, jyewe, Tireziyasi, ndunda iniveri yose mu kinanda mu ntumbero y'urugendo rwa nje.



Mbega ububasha !

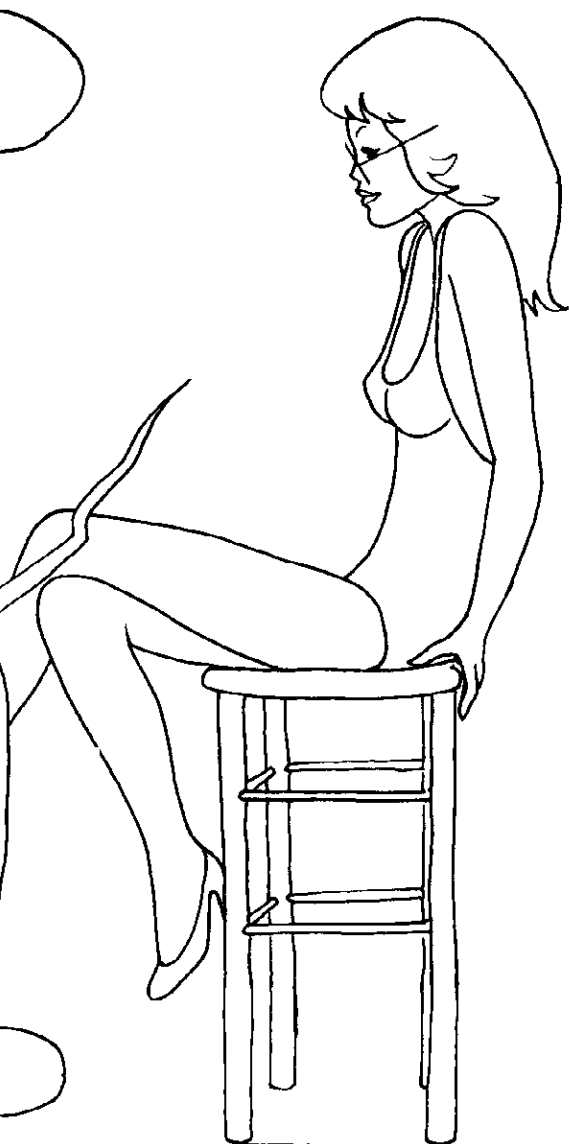

Ni amayobera ! igishorobwa
ntigishobora kwegeranya iniveri !



Mi !

Ntabwo ari ibijyanye no
kwegeranya iniveri, cyangwa kugabanya
umuvuduko w'isukwa ry'igihe. Ingendo n'ibihe
ni ingaragazi gusa. Byose ni mpitabitekerezo.
Iyo ni isi ya **ROLATIVITE**.

Arikose? Iniveri, isa n'iki ?



Byose bitandukanywa n'umuvuduko w'indorerezi.

Umuvuduko ujyereraniye n'IKI?



Igitekerezo nyamukuru ni uko abantu
babiri bagenda k'umuvuduko ungana V
berekeza hamwe, babona kandi batura
muri Iniveri mu buryo bumwe.

Ariko tugaruke ku mudeli wa Parikye Kosimikye. Uzabonako ku
binyabuzima bimwe, Iniveri ishobora gufata intera yihariye.

IYO IGIHE GIHAGARIKA ISHIBUKA RYA CYO

CYANGWA
IMITERERE YA ROHO
YA FOTONI



Hagomba kuba habaho rwose umuvuduko ujyana ubwato bugendera mu nsi y'amazi ku burebure bugana hasi aho isunika riturutse hanze ringana n'isunika ryo muri rezoluvuware ?

Biryo se hakurikira ho iki ?!!??...

Ukurikije ishumikiranyo nyakuri ry'ibitekerezo, igihe kigomba guhagarara !?!



Turi hagati na hagati ya MATOSI

Ariko muri Parikye Kosimikye ya Bwana Aluberiti, ibi bizashyika igihe tuzaba turi hagati na hagati ya palaneti gitonyanga cy'amazi.



Ubwo burebure bugana hasi tuzageraho igihe umuvuduko wacu uzangana na km 300 000 ku segonde.

Kandi aho ni indiba y'ibintu byose. Ntushobora kujya muni ya ho.



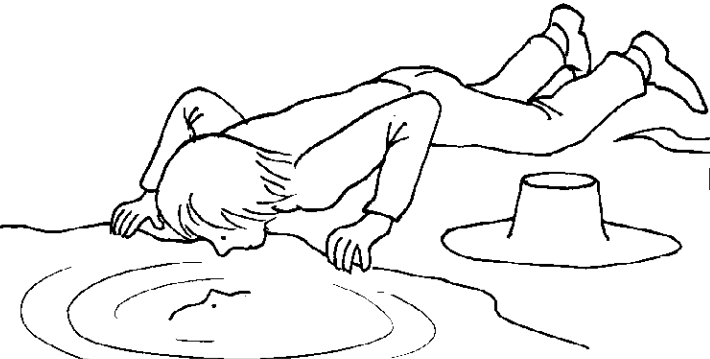

Ariko se ni nde utuye kuri iyo ndiba ya Koronosi, hagati na hagati y'ibintu byose, ahaba ya zero yihariye y'igihe ?...

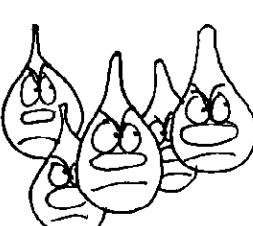

Igihe ni ikibazo kireba abandi

ZAFOTONI

Aribwo bumanyu buto bugize urumuri.

Kuri twe, ntabwo ari ubuzima !



Ariko se ubundi, izo fotoni, nshobora gupima umuvuduko wazo. Ziyenda ahantu h'uburebure bungana na D , mu gihe kingana na t , kandi umuvuduko wa zo ni $D/t = \text{km } 300\,000 / \text{s}$

Izo nyagwa, ziravuka, zikanapfa !

BULEBE
BULEBE



Ariko, Anselimi, urabizi neza ko igihe, gifata amajwi y'ubwinshi.

Ubwo ni Uburyo BWAVE bwo kubaho igihe kiriho.
Kuri fotoni, ibyo biratandukanye cyane. Muri sisiteme yayo bwite,
ivuka n'urupfu ni ibiza byomekanye, kimwe cyometse ku kindi.



Urashaka kuvuga ko kuri yo igihe
kitagira IGISOBANURO CY'IHAME ?

IGIHE NYAKURI cya fotoni gisobanurwa
muri make n'agahe gato cyane k'ubu, kari hagati
y'igihe cy'ivuko ryayo n'igihe cy'urupfu rwa yo.
Fata espase-gihe ya dimansiyo 3, (x, y, t) .
Uyibyataraje ukurikiye intumbero y'igihe hasigara
ikibyatarare gifite iyuma n'imbere. Ni iryo tandukaniro
hagati y'uruhande rw'imbere n'urwinyuma ryerekana
intumbero y'igihe cya fotoni.

Ibyago...

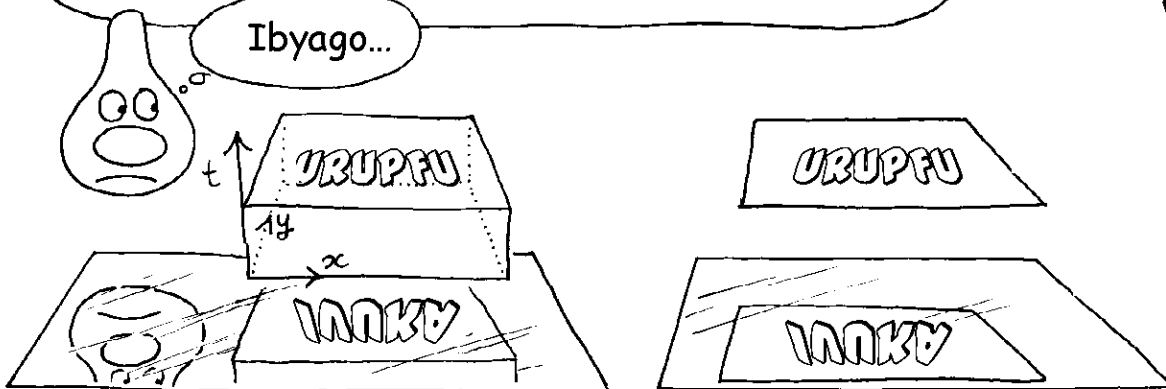

Urabona, Anselimi, Ibintu byose bifitanye isano.
Urebye ibintu bimwe byiruka, wagirango bigira ubuzima.
Ariko kandi nta buzima bifite !

Jyewe, ndifuza neza umuntu
wambwira umunsi umwe kuki igihe
kigenda giturutse muri kahise
kigana mu bizaza kandi ntikibe
cyashobora gukora urugendo
rusubira inyuma !

BULEBE
BULEBE

Ese bifite akamaro ?
Muri gariyamoshi y'igihe,
Twese twicara buri gihe
tureba aho tugana.

Ese nimumbwire,
mwahindutse abasazi,
cyangwa hari ibindi
byabashyikiye ?

Nigeze kuvugako iyaba
intumbero y'igihe yarihindukijwe
mu kanya gato, nta n'umuntu
n'umwe wabimenya !



Byiza, jyewe, ndifuza rwose,
naho byaba agaha gato, kujya mu mwanya
wa ftoni kugirango byibuze ngire
igitekerezo ftoni ifite kuri iniveri.

Ntabwo bishoboka gushushanya esipase-gihe ya
dimansiyo ennye. Ariko dushobora, muri esipase
ya dimansiyo eshatu, gushyiramwo ingendo
zinyuranyemwo z'ibintu byose byo muri Iniveri, z'uduce twose, nk'uko indorerezi
iri ahantu hamwe (byiswe ko) itanyeganyega, yaba ibibona, mu gihe cy'ubuzima
bwe bwose.

Ubwoko bwa ftoni
ituje, iri hamwe, ifite
dimansiyo eshatu...

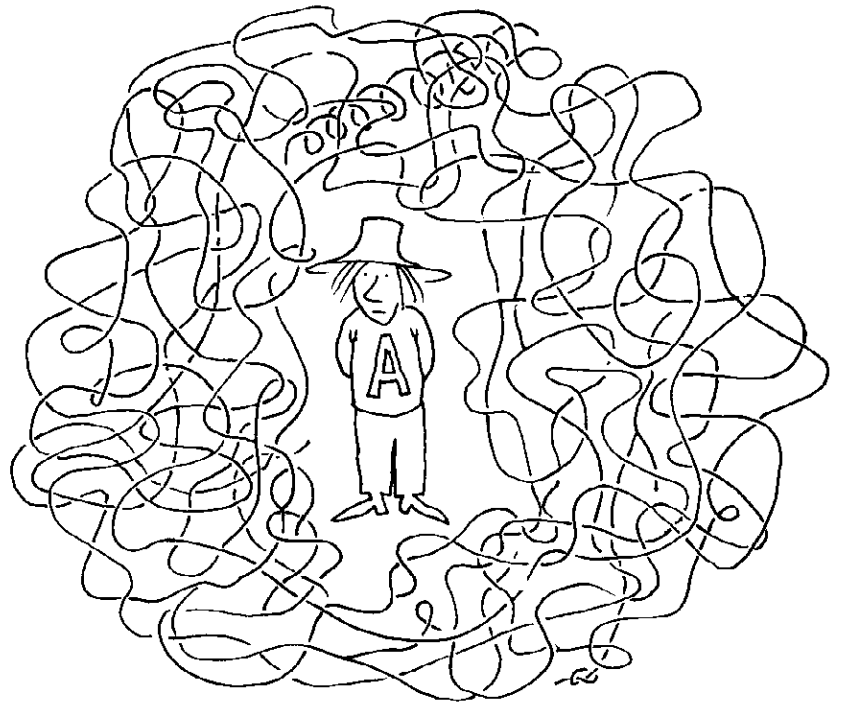
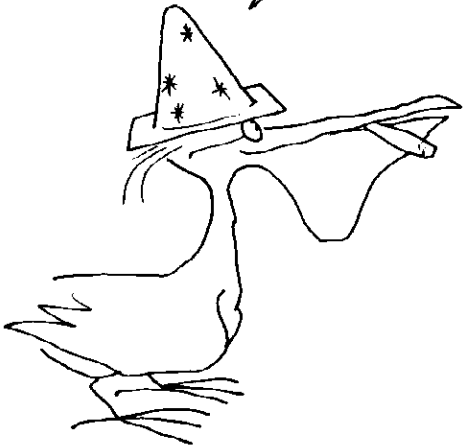

Umofuko nyawo w'umutsima!...



Twabona ikinyagwa kimeze nka kashe
ya Jegise cyangwa ikibabi cy'ubutare

Ufatiye ku bijyanye n'UBUREBURE, iyi iniveri irakweduca.

Niba indi ndorerezi igenda n'umuvuduko V itumbereye ahariho hose, byose biba nk'aho habaye itsindagira rya Iniveri (hamwe n'iry'indorerezi) ukurikije iyo ntumbero.

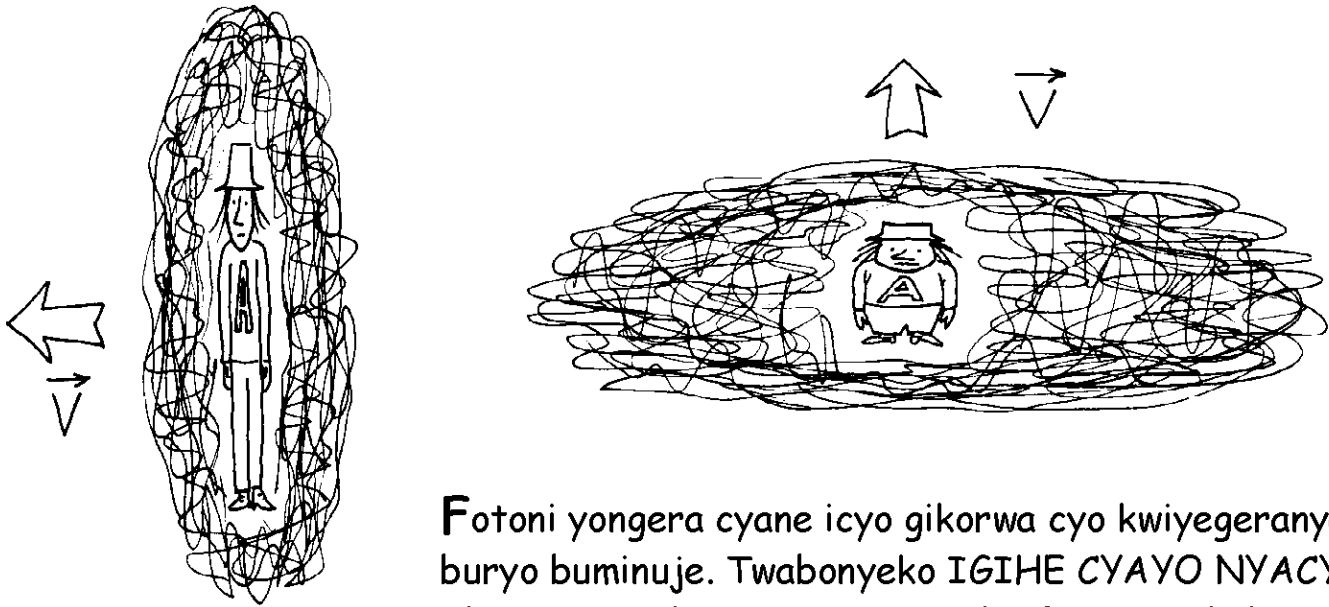

Fotoni yongera cyane icyo gikorwa cyo kwiyegegeranya mu buryo bumunye. Twabonyeko **IGIHE CYAYO NYACYO** cyabyatarajwe byuzuye neza. Iyaba fotoni yashoboraga kureba igishushanyo cya Iniveri yose, yari kubona ko iyo iniveri ibyataraye cyane hakurikijwe intumbero y'urugendo rw'iyi fotoni. Bityo biragaragara ko isi ya fotoni ni **INYADIMANSIYO-EBYIRI**. Kandi nayo ubwayo yaba yibera muri iyo si iteye amatsiko nk'agafungwa gato, kabyataraye.

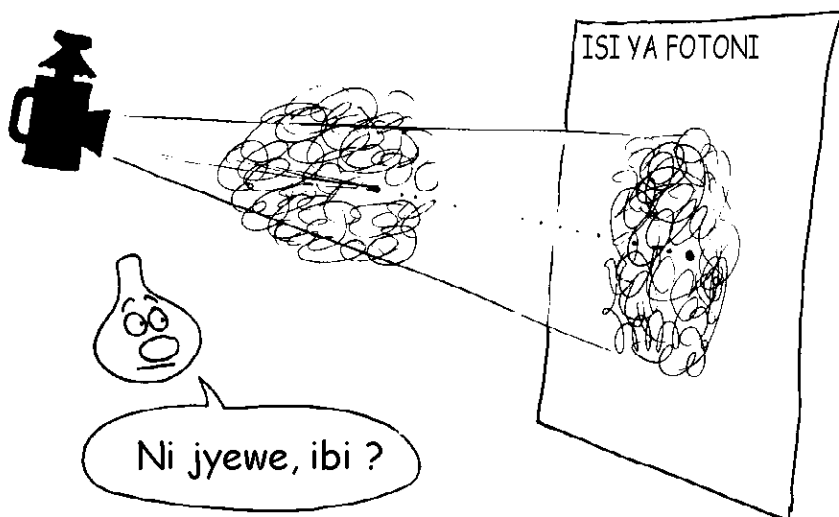

Birasa n'ibyo umuntu yabona yohereje, kuri ekara, ishusho ya kashe Jegisi (indorerezi iri hamwe itanyeganyega) akoresheje itara rimurika mu nzira y'intumbero y'urugendo rwa fotoni.

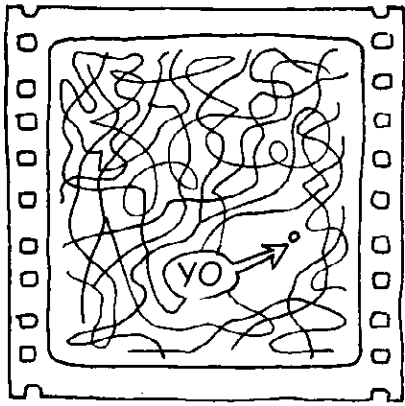

Kugirango usobanukirwe imibereho ya fotoni, wakagombye kuyifilima k'uburyo utunga kamera mu ntumbero y'urugendo rwayo kandi ugerekeranya amashusho yose y'iyo filime.

Mu bigaragajwe ubwambere: isi ya fotoni

Nk'uku nguku.

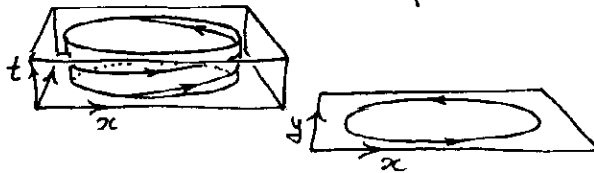
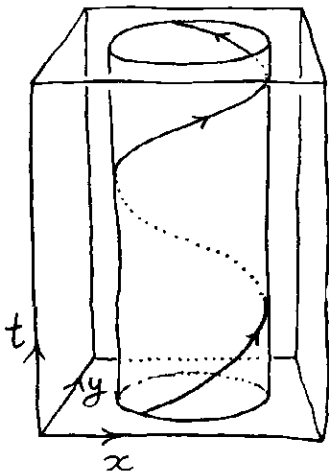

Rubyataraye hakurikijwe intumbero y'igihe, urugendo rw'igitagangurirwa rwahinduka iserikyeri !

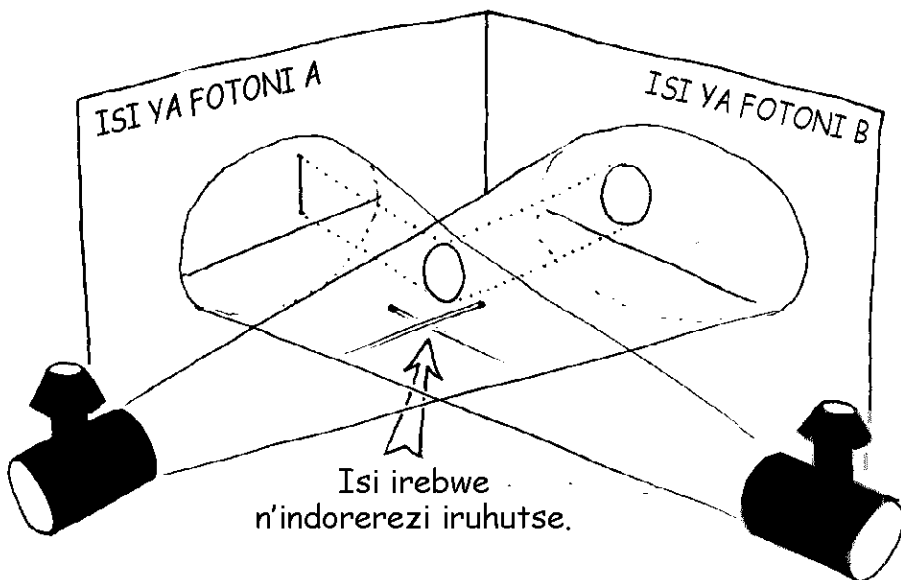

Fotoni ebyiri zifite intumbero zitandukanye z'ubusakare zagira "ibitekerezo by'isi" binyuranye.

Ficitiri !





Ariko
se Iniveri ubundi
ni IKI ?

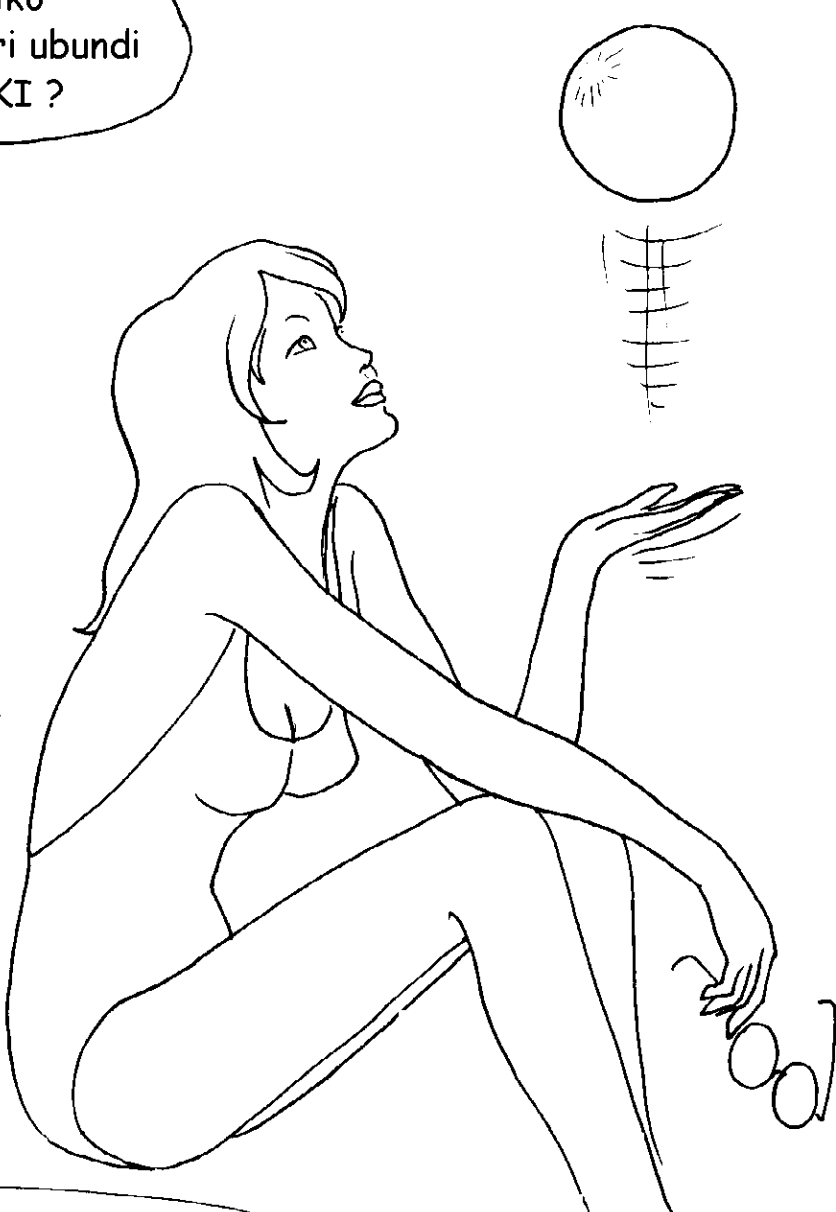



Ni, ibintu byose kandi
n'ubusa icyarimwe.
Hariho uburyo
bunuranye igihumbi
na rimwe bwo kuyireba,
bwo kuyigaraguramwo.



Za x, za y, za t, ibyo byose
ni inkuru zo gusetsa !

Yohi, mu buzima
busanzwe bwa buri muni,
birafasha...



Arirekura mu
binezero, uriya
musore !

UBUDAHINDUKA BW'UMUVUDUKO W'URUMURI IHINDUKA RYA MASE





Za fotoni !
ndazibona !

Mbega ukuntu KORONOSI
ifite ubujyakuzimu burebure !

Imbarabujyakuzimu
yanjye irerekana
umuvuduko V1

Iyo fotoni igyenda urujyendo
D1 mu gihe t1

Ndagabanya D1 na t1,
mbonye km 300 000 /s

Ongyera umuvuduko,
bwana Aluberiti,
ongyera umuvuduko !

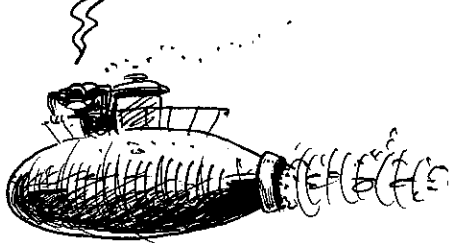

Aha, dore mfite umuvuduko V2 uruta V1. Ngiye gusubira gupima.

Iyi fotoni iragenda ahantu D2 mu gihe t2

Umuvuduko wayo ni $D2/t2 = \text{km } 300\ 000/\text{s}$.

Biratangaje. Mbonye ibisa na byabindi !

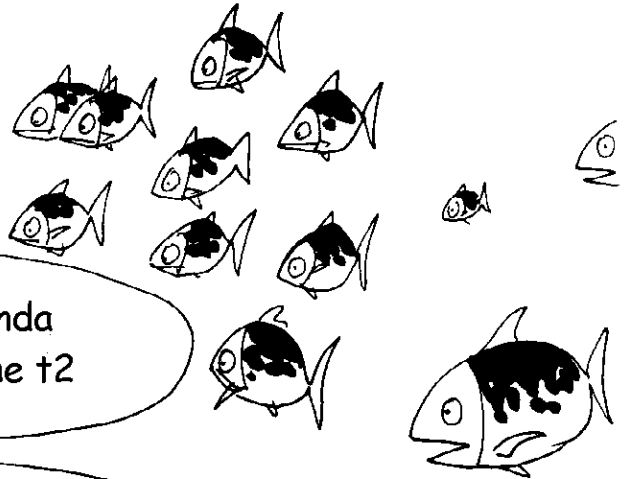

Indorerezi zose, utitaye k'umuvuduko wazo, zibona mu bipimo byazo umuvuduko umwe c wa za fotoni, utwo tumanyu tugize urumuri. Zifite rwose imiterere yihariye muri Parikye Kosimikye. Ibintu bigaragara nk'aho zijyenza nk'udutara duto dufite "reyo" izenguruka n'umuvuduko-nyanguni udahinduka, birtyo ukohereza ishusho yazo kuri za siferi zisangiye santeri zigize Koronosi. Hakurikijwe umukino nshuro-ebiyiri w'ubuhinduke bw'urugendo n'igihe nyacyo, indorerezi zibona ntampindukirane ko $c = D/t = \text{km } 300\ 000/\text{s}$.

Ubwo budahinduka bw'umwihariko bw'umuvuduko w'urumuri, bw'umuvuduko wa za fotoni, bwashyizwe ahabona mu buryo bw'amajyeza, mu 1881 na Mishelisoni na Moruleyi.

Imyaka mirongo itatu n'ine nyuma ya ho, mu 1915, Eyinshiteyini yerekana ku mugaragaro, umudeli usobanutse wa esipase-gihe, udashobora kwerekana neza ubwo budahinduka bw'umuvuduko w'urumuri, kandi anatangira kubaka esipase-gihe nshyashya kuburyo inshusho-gitekerezo cyayo kigaragazwa na Parikye Kosimikye: esipase-gihe ya ROLATIVITE.

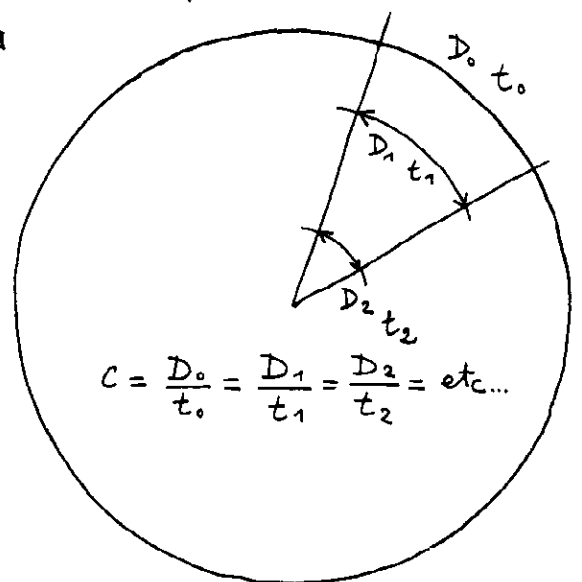

Tubagezeho ! onjyera umuvuduko, bwana Aluberito, ongera umuvuduko kandi !

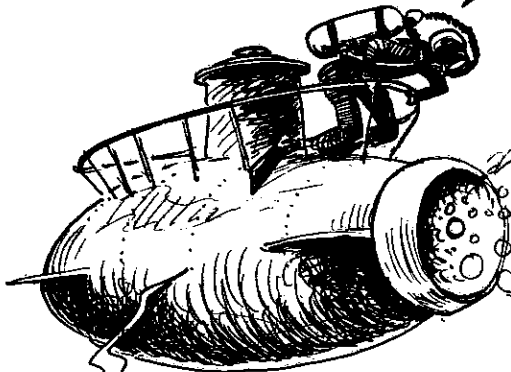

Ntibishoboka, mwana wanjye

Kubera iki ?!?

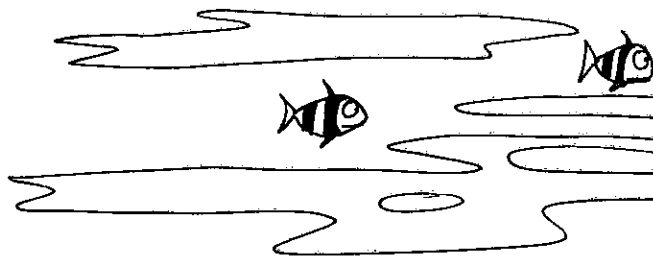

Ubwato bwanjye bugendera munsu y'amazi butsimbura bukoresheje imbaraga-ndwanyagikorwa. Koronosi ntirwanya na gato iryo tsimbura. Ngomba gusa gutsinda INERISI. Iyo ngeze ku muvuduko V kandi ngahagarika moteri, ubwo bwato bugendera munsu y'amazi bugendera kuri SERIKYERE NINI ya siferi, ihuje n'ubwo bujakuzimu (*)

(*) Ni ukuvuga JEWODEZIKYE imwe y'iyi siferi. Murebe muri JEWOMETIRIKONI.

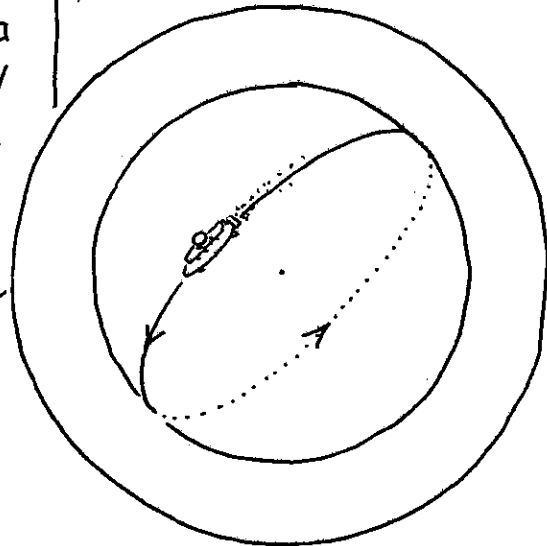

Ikibazo kiri he? Subira watze moteri kandi ukomeze wongere umuvuduko, biryo tuzasatira cyane ziriya nyagwa za fotoni.

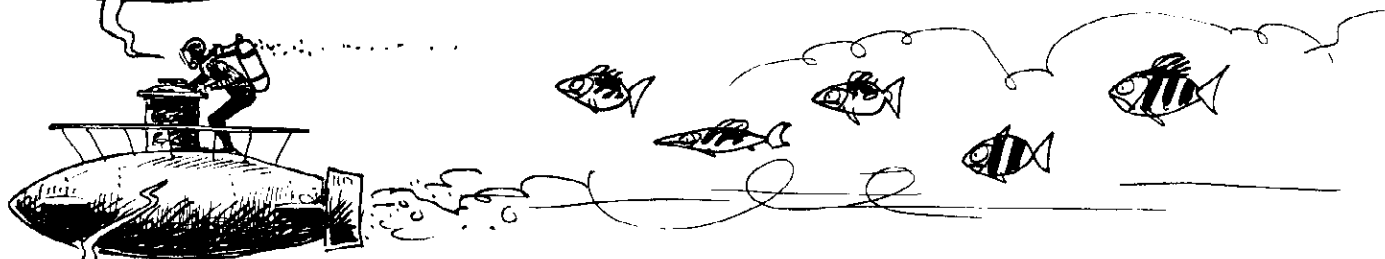

Mbega ye, uko tumanuka twika ni nako KORONOSI iremera cyane. Uko tumanuka cyane, ni nako isatira balasite zacu noneho tukarushaho kuremera. Mase yacu iriyongera.

Inyandiko y'akazi:

Turashaka kurwanya igitekerezo kitari cyo: abantu bavugako kujyenda binanura. Mu by'ukuri, biranyuranye ! igikorwa gisanzwe cyo kuva mu miterere y'uburuhukye (mase m_0) byongera mase mu nyemeranya ya:

$$m = \frac{m_0}{\sqrt{1 - \frac{v^2}{c^2}}}$$

Ariko kandi, iyo upfuye guhagarara usubirana mase yawe y'intangiriro m_0 .

Ubuyobozi



Ariko ntibyumvikana ! twari tuhageze... Turi k'umuvuduko ungana na 0,995 c kandi mfite icyizere ko nshobora kubakoraho.

Mase yacu ubu yikubye inshuro cumi. Dusa n'abatacyongera umuvuduko nabusa !

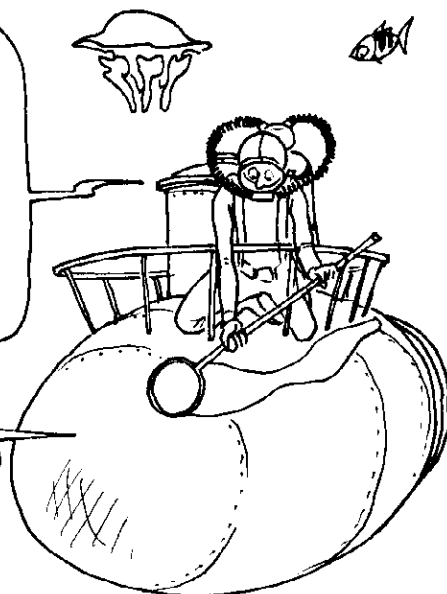

Kuri $V = 0,99999 c$ mase yaba yikubye inshuro 224 . kandi bigenda mu rukurikirane nk'urwo...



Ntacyo bimaze gukomeza ubigarukaho.
Twakoresha ingufu z'umurengera uhebuje
dushatse gushyikira ziriya fotoni.
Ndagabanyije umuvuduko, itonde !

He la !

VOROROOO!

Pifi !... Mbega
urujyendo nshakishiriza.

Nimba mbyumva neza, uko uha ingufu
ikintu ni nako wongera mase yacyo.

Birumvikana kuko imbaraga na mase, ni kimwe: $E = m$



By'ukuri, bitandukanijwe n'umubare umwe udahinduka... ari wo kare ya c .
Muri icyo gihe tuzandika: $E=mc^2$.
Humuu... ni ikibazo gitoya cy'ibipimo mfatizo.
Niba igipimo mfatizo cy'uburebure cyanganaga na miliyoni Magana atatu za metero,
byazakwandikwa : $E = M$

Ariko se kariya gaciro ka miliyoni magana atatu za metero kw'isogonde gaturutse he ?



Mu mwanya wawe, nacurika ikibazo:
ese i metero kw'isonde biturutse he ?

Nda...eehi... yego ?

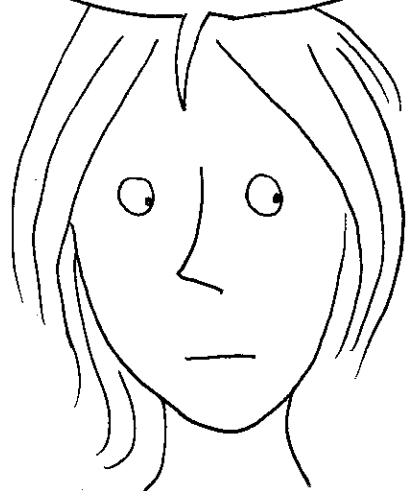

Ni igipimo cy'umuvuduko kinogeye bihebuje, ni urugero kosimikye, muri iniveri yose. Naho I metero kw'iseconde ni agapimo k'utunusu k'aho ngaho.

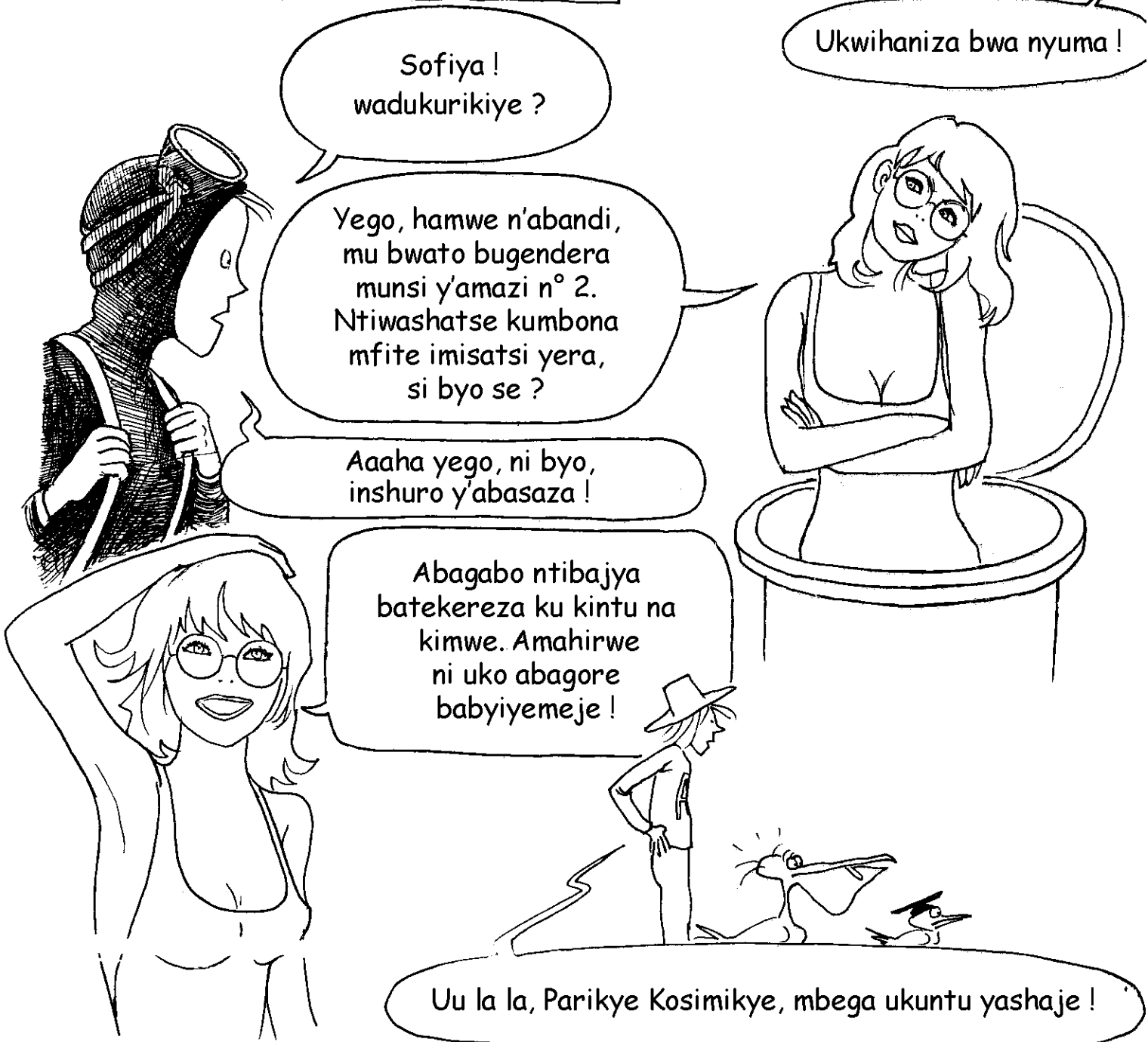
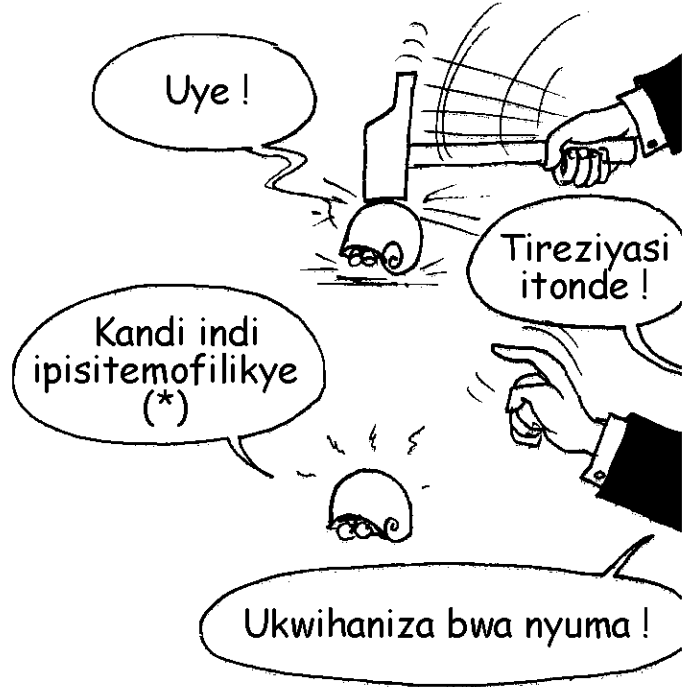

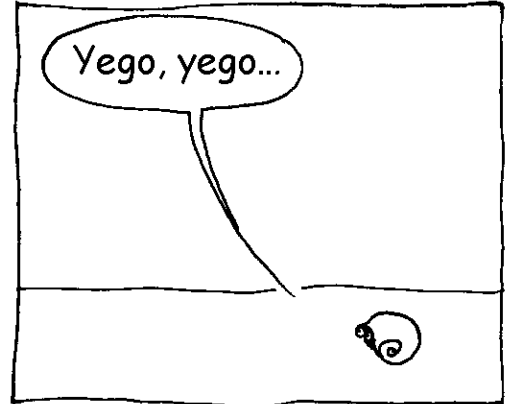

Episitemoyedere ni Inyubako y'Ubumenyi. Buri gihe irasadagurika, igakonkoboka, hanyuma ikongera ikavuka iturutse muri bya bisenyukye byayo.

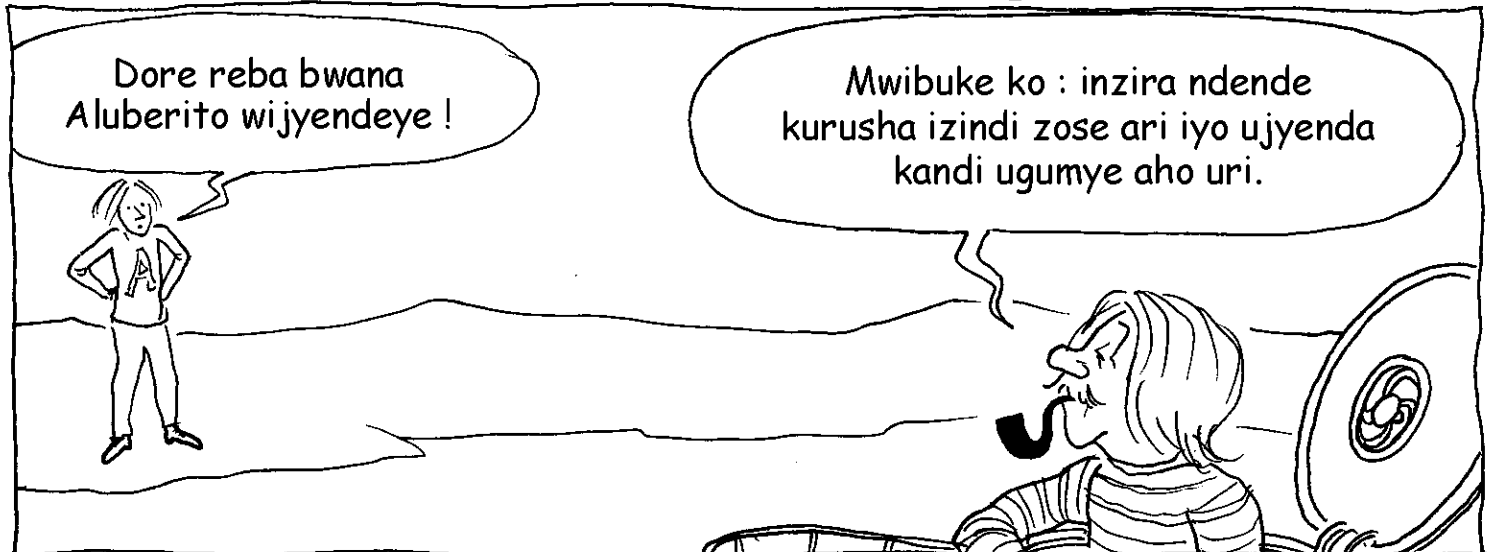
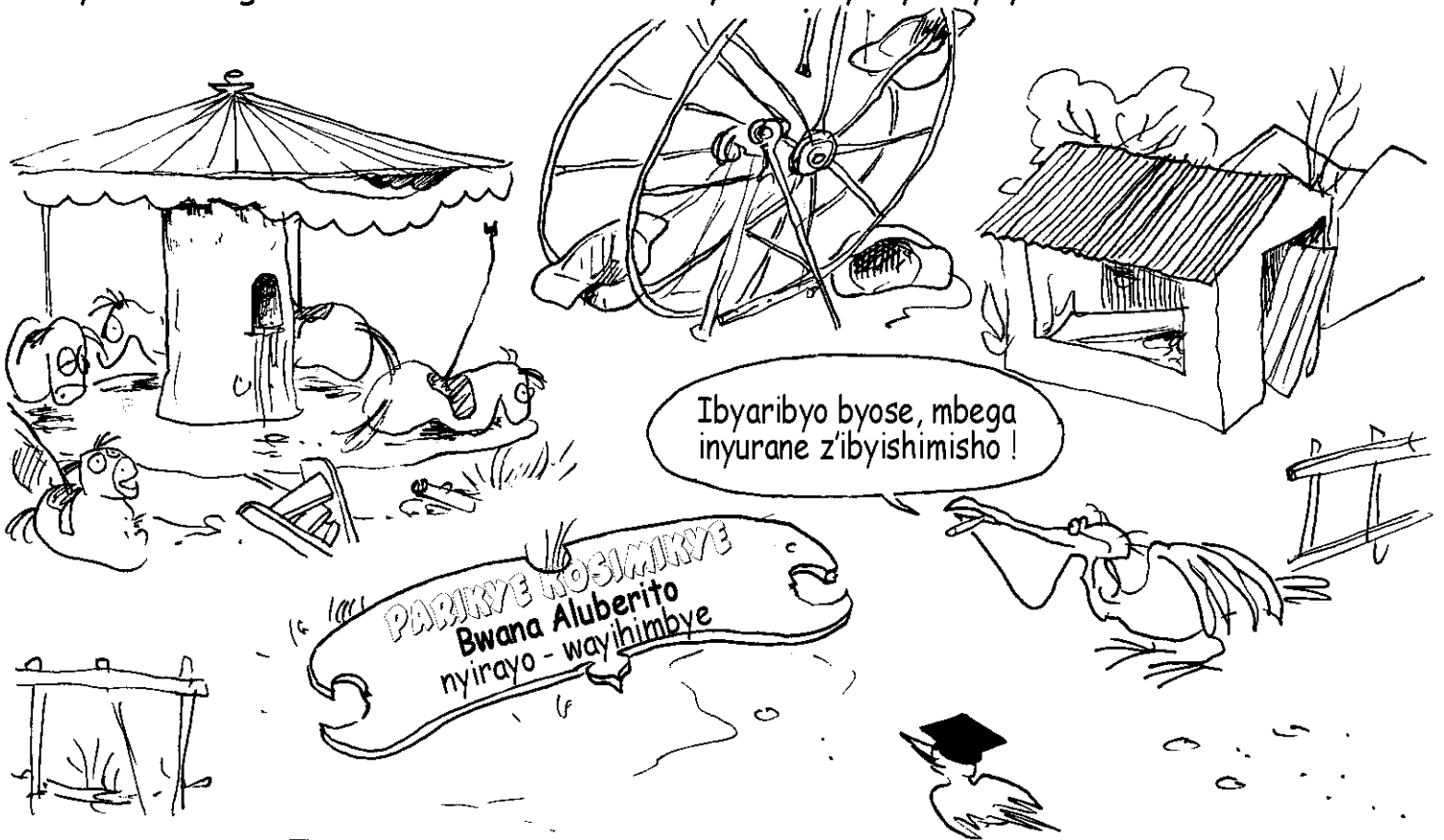

Buriya hariya
yashatse kuvuga iki ?

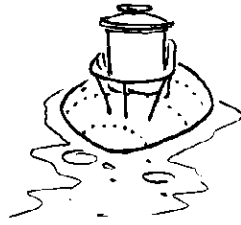

Gusa ko, muri esipase-gihe yacu,
umurongo ugororotse ni inzira ndende
iruta izindi iruta izindi zose zituruka
ku kadomo kamwe zijya ku kandi.

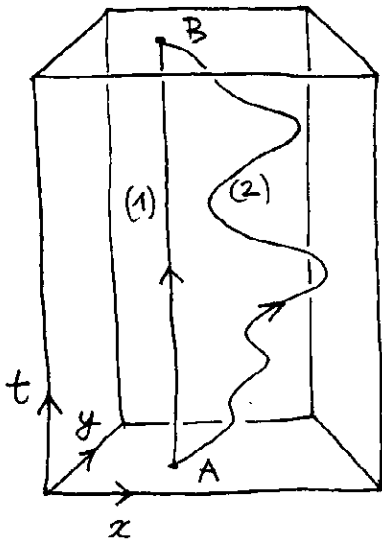

Urugero, urugendo rugororotse AB ni urwo
ujyenda ugumye, uhagaze aho uri. Urugendo ruhetamye
(2) rugendwa n'ufite cyangwa n'igifite umuvuduko.
Tuzi KO, muri iyo mibereho, **IGIHE NYACYO**,
icy'umugenzi (ugereranije n'ubuhangane
bw'icy'indorerezi igumye hamwe), kizahita gacye.

Urugendo nyarwo, muri esipase-gihe yacu, ni igihe
nyacyo cyahise. Muri iyo ndoro y'ibintu, urujyendo
ruhetamye rwaba "rugufi cyane" kurusha urugendo
rugororotse.

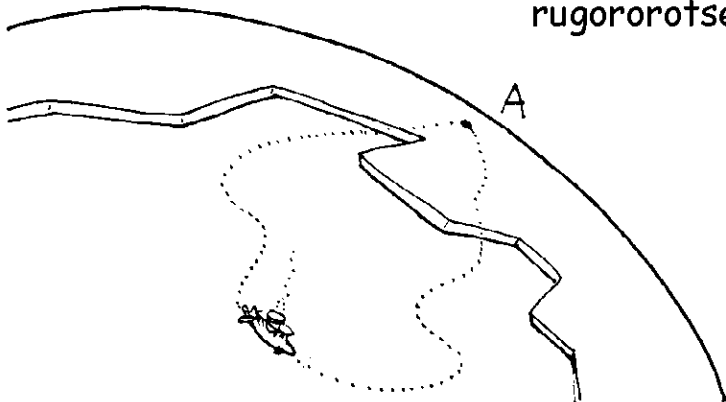

Anselimi !



Ibyo,
ni byo pe !

Gukora urugendo
rutuma uguma aho uri
ni imyumvire nyabasazi !

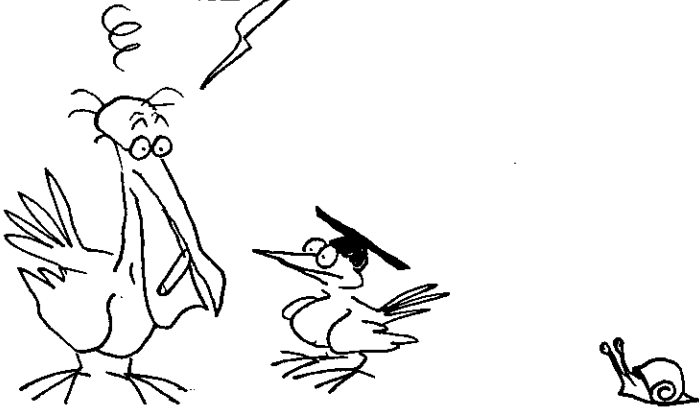

URUGENDO RUDASHOBOKA

Ijoro ryaguye kuri
Parikye Kosimikye.

Sofiya,
inyenyeri,
ni iki ?

Ni amazuba
nk'iri ryacu.

Birtyo rero
Isi izenguruka iruhande
y'INYENYERI-ZUBA.
Uremera ko ayandi mazuba
afite nayo amapalanete,
n'andi masi ?

Yego, Anselimi.







Kandi inyenyeri
itwegereye kurusha
izindi iri kuri... ?

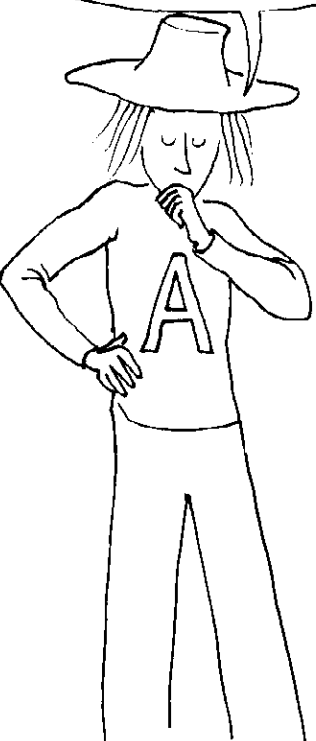

Urumuri rukoresha imyaka ine ngo
rutugereho ruturutse ku inyenyeri iri
bugufi yacu cyane ari yo yitwa
Alufa do Santore.



Ni ukuvuga ko iri
ku birometero bingana
n'ibihumbi mirongo ine
by'ama miliyari uturutse
kw'isi yacu.



Ariko kandi Pulutoni yo,
iri ku mipaka ya sisiteme y'izuba,
iri ku birometero miliyari eshanu
uturutse kw'isi yacu, ni ukuvuga ahajya
kungana n'amasaha-rumuri atanu.



Ni ukuvuga ko ari hafi inshuro ibihumbi cumi.

Bwana Aluberiti yansobanuriye ko hakenewe imisozi n'imisozi itagira umubare by'ingufu kugirango ugire umuvuduko ujya kwegera uw'urumuri. Twavugako, kugirango ujye hejuru y'umuvuduko wa km 100 000/s



Aha hari ibyumba bibiri, igikoni n'ubwiyuhagiriro bwa Lanturulu.

Dufate ko mfite imoteri n'yendajuru iha imodoka yanjye inyongeramuvuduko ya "g" imwe, ni ukuvuga ko umuvuduko wanjye wiyongera ho imetero cumi buri sogonda.

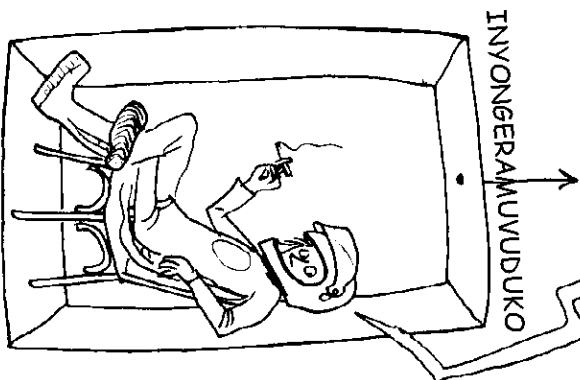

Inkurura igaragara ihwanye n'uburemere bwa njye, kandi biryo nshobora ku yihanganira mu gihe kirekire gishoboka nk'uko mbishaka.

Muri ubwo buryo, nkeneye amezi ane kugirango nshobore kugera k'umuvuduko w'ubunyaruke bwa km 100 000/s. kandi muri icyo gihe, nzaba naragenze igice kimwe kw'ijana cy'urugendo.



Nzaba nsigaje rero imyaka cumi n'ibiri y'urugendo, tudashyizeho ayandi mezi ane yo kugabanya umuvuduko.



N'uwundi mwanya
ungana n'owo wokuvuga
iby nabonye yo.

Hari amahidwe make ko twaba
turi abanyabuzima twenyine muri Iniveri.
Ariko kandi, nimba hariho andi mapalanete
atuwe, iyambere itwegereye yaba iri mu
myaka-rumuri iruta cyane iyo ine !

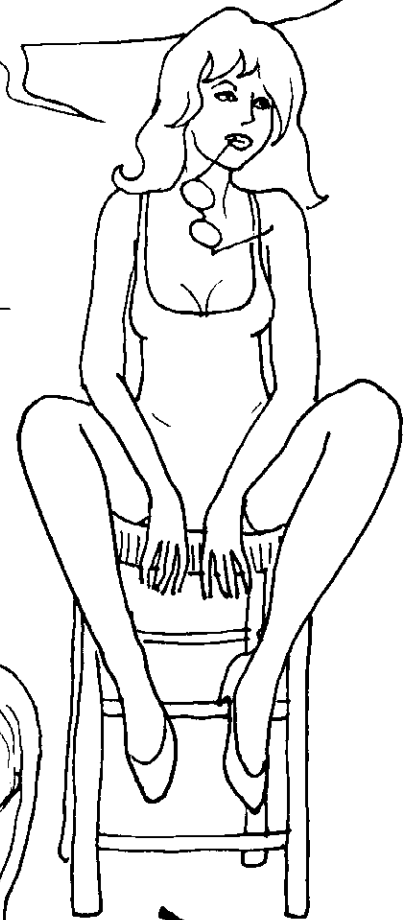

Mu yandi magambo,
gukora urwo rugendo ukurikiye
ayo mahame ya Parikye Kosimikye,
byasaba ko umuntu abiharira
ubuzima bwe bwose !

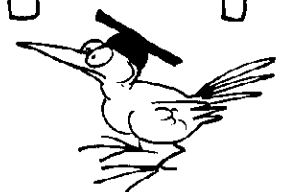
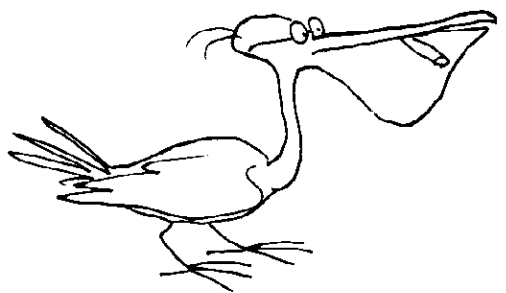

Nonese dukore iki ?

Ndabona uyu muhungu
adahagarara na gato ?

Ese urwo rugendo
nti rushoboka ?



Kugenda k'umuvuduko uruta uw'urumuri
ntibyumvikana, ntashingiro bifite. Ni nko gushaka kujya kure
ugana ikuzimu harenze santere ya Parikye Kosimikye !



Yenda
Parikye Kosimikye si
umudeli uhebuje



Ntabwo ari ibyo !
Ibyo ntabwo bimbwira uko nakora
urujyendo rungana ku zindi nyenyeri
mu mwanya usobanutse.



UMUSOZO