

Savoir sans Frontières

Indurubuli z'Anselme Lanturlu

Jean~Pierre Petit



<http://www.savoir-sans-frontieres.com>

Cyera habayeho i "Borderie" ...



Ngibi, Bwana

Yee, nibyuma ubishyire mu ziko. Ngaho jya gutashya.

Reba ili ziko nalihawe na data, hamwe n'iyi sambu. Nawe yali yarabirazwe na se, nawe wabikomoraga kuli sekuru.

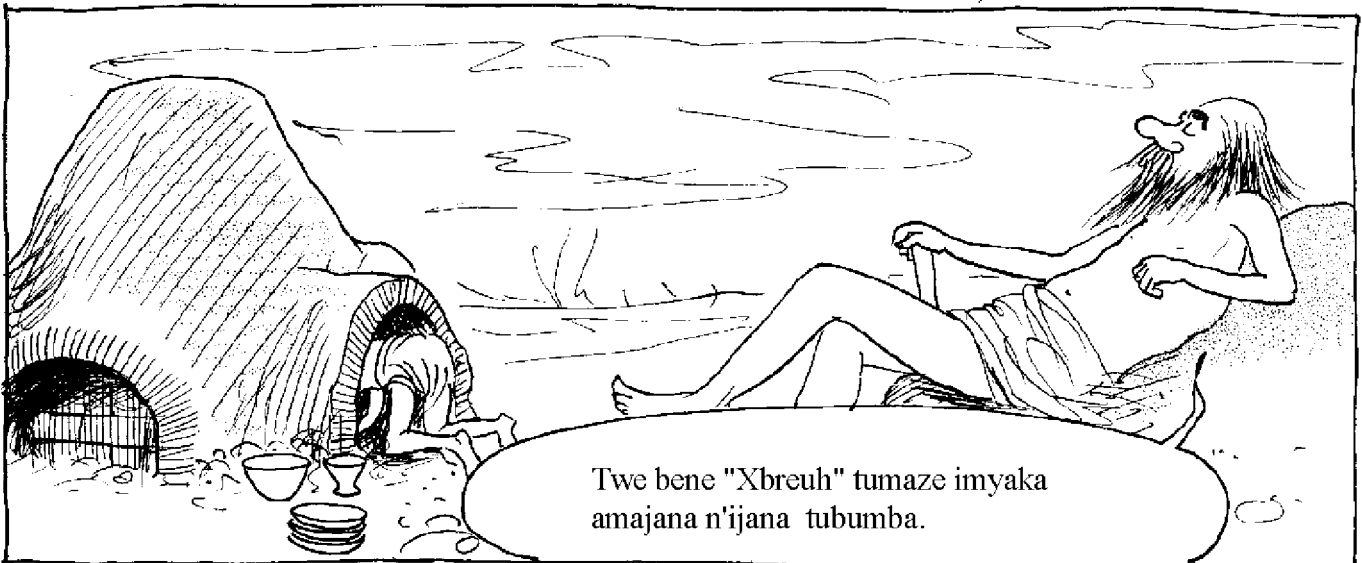

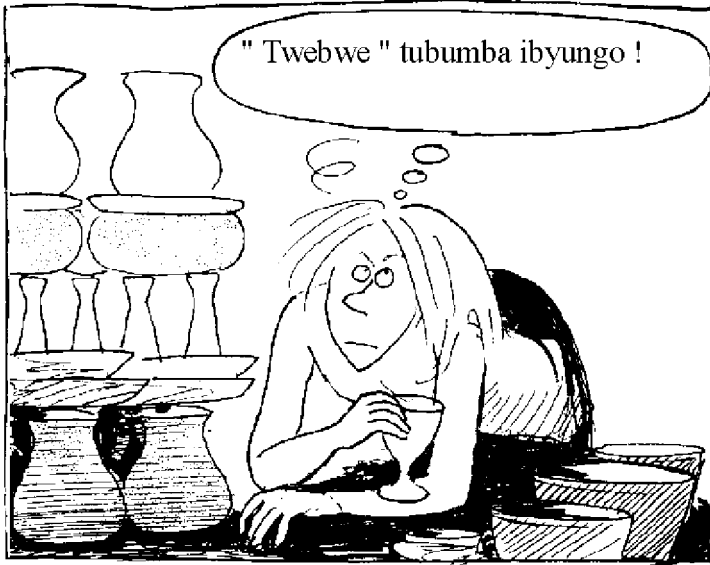

" Twebwe " tubumba ibyungo !

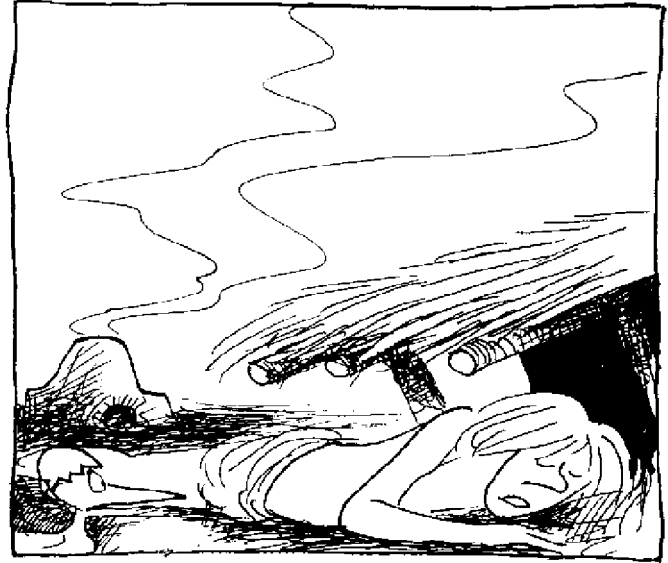

Sigaho, "Cornacul", rekeraho kunyeganyega mbone uko nkwikoreza ibyo tujya kugulisha !



Aha, dore wa musaza " Kroumir " "

LE TROC



Ngaho, amafi ane ku cyungo kimwe

Oya, atandatu

Baracilikanya igihe kugirango baze kumvikana mu GUSHYIRAHO IBICIRO.

Maze se, wowe uraho ?

Ntako, murobera amafi.

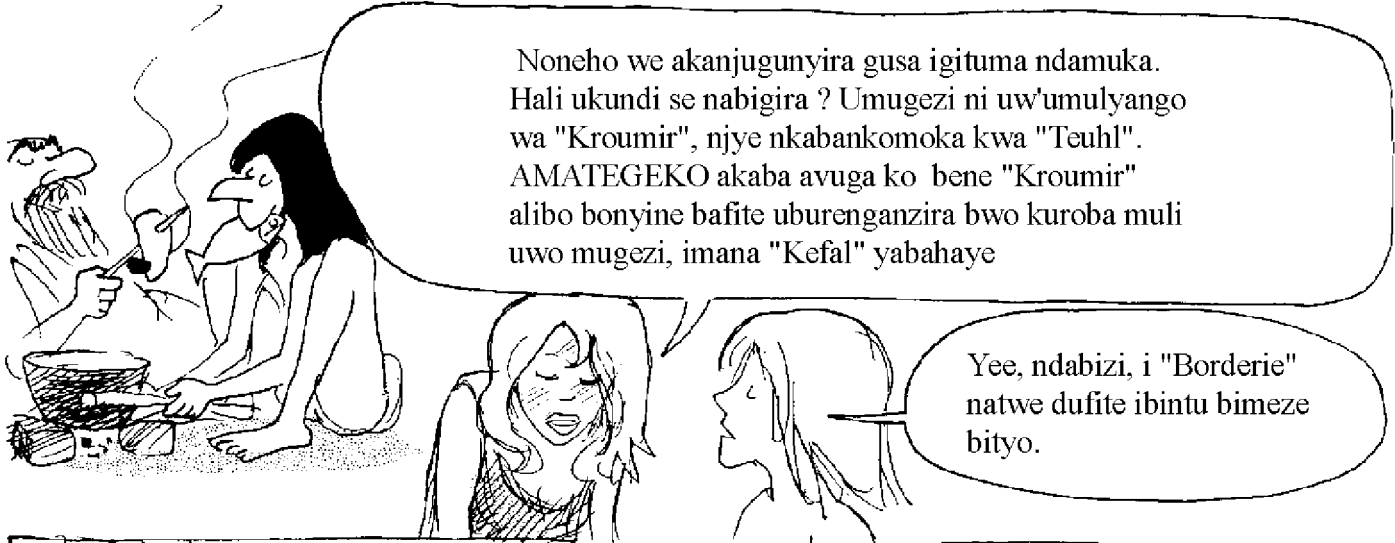

Noneho we akanjugunyira gusa igituma ndamuka. Hali ukundi se nabigira ? Umugezi ni uw'umulyango wa "Kroumir", njye nkabankomoka kwa "Teuhl". AMATEGEKO akaba avuga ko bene "Kroumir" alibo bonyine bafite uburenganzira bwo kuroba muli uwo mugezi, imana "Kefal" yabahaye

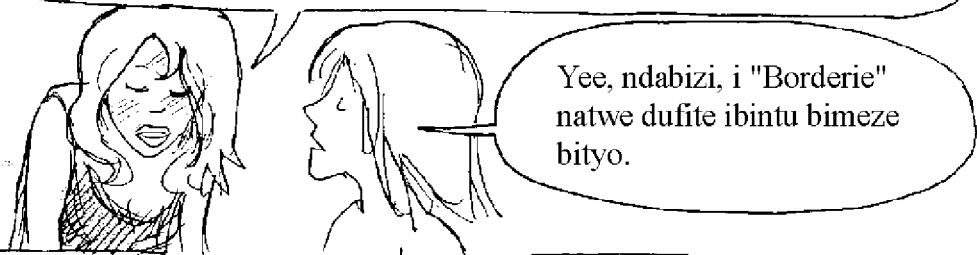

Yee, ndabizi, i "Borderie" natwe dufite ibintu bimeze bityo.

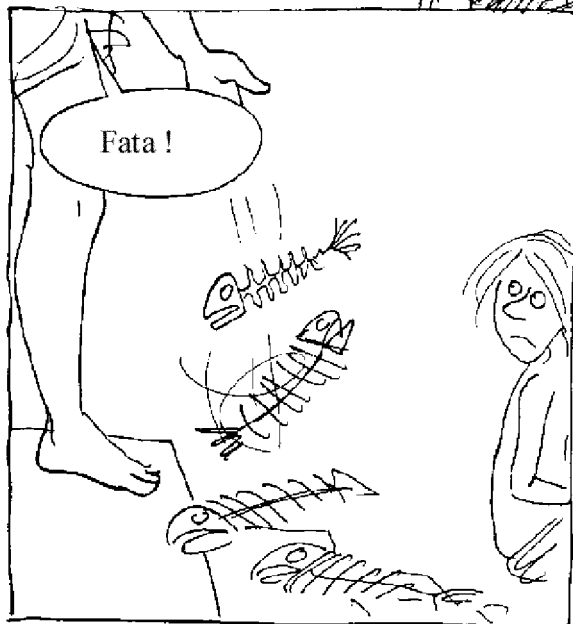

Fata !

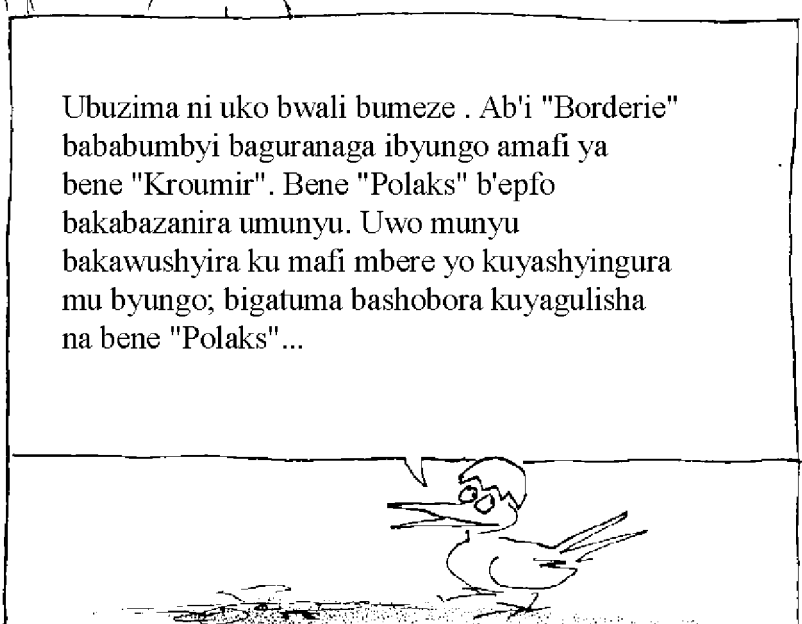

Ubuzima ni uko bwali bumeze . Ab'i "Borderie" bababumbyi baguranaga ibyungo amafi ya bene "Kroumir". Bene "Polaks" b'epfo bakabazanira umunyu. Uwo munyu bakawushyira ku mafi mbere yo kuyashyingura mu byungo; bigatuma bashobora kuyagulisha na bene "Polaks"...

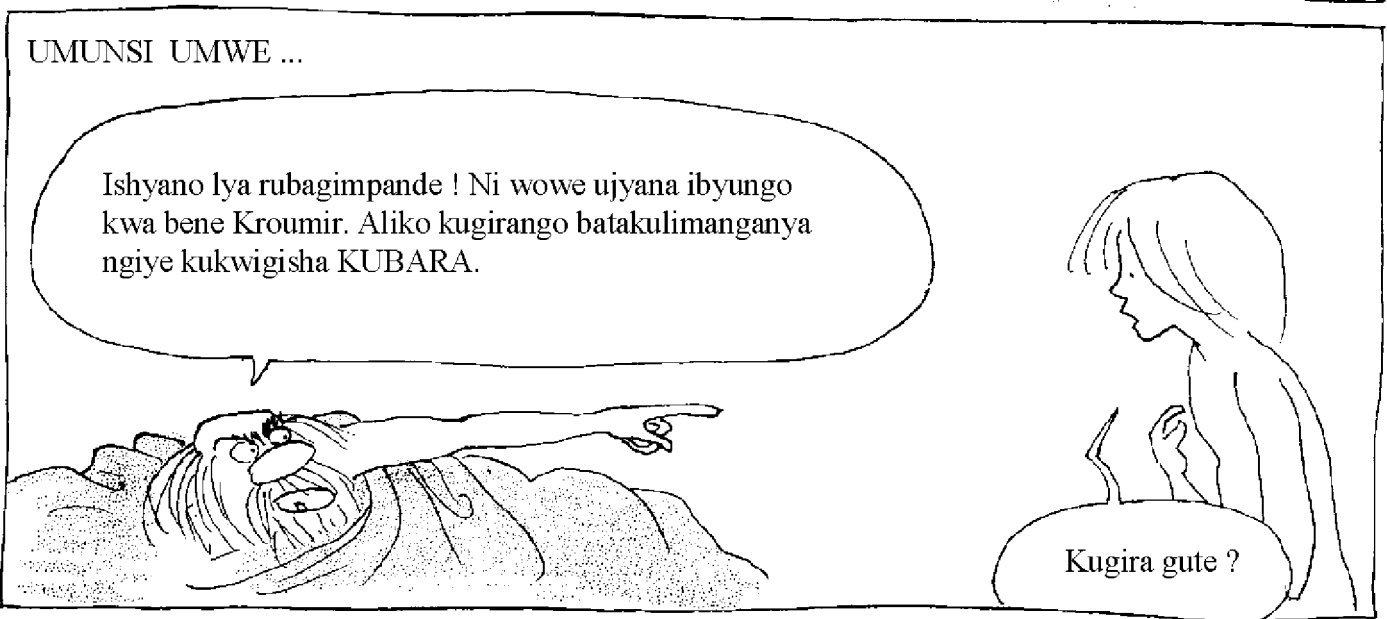

UMUNSI UMWE ...

Ishyano lya rubagimpande ! Ni wowe ujanya ibyungo kwa bene Kroumir. Aliko kugirango batakulimanganya ngiye kukwigisha KUBARA.

Kugira gute ?

Ngiye kukwigisha IBANGA LY'INTOKI ? Umva, wa musenzi we, urabona ibiganza byawe ? Urabona ko bifite intoki ? Buli rutoki rukaba rufite ingingo ?



Sinali nkwiye kubikwigisha aliko nintabikora mwene "Kroumir" araza kukulimanganya.



Kandi njye, sinshaka abanyambura.

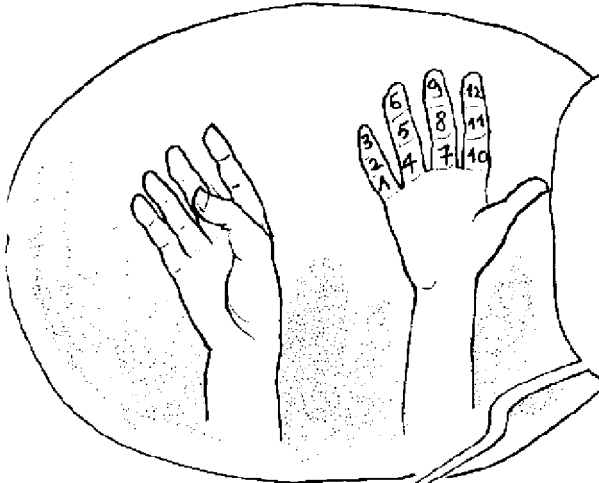

Reba, ukoresha igikumwe kugiragngo werekane ingingo, muli uyu murongo. Nurangiza uraba ugize IDUZENE. Ufate agashishwa k'igiti ko kwandika byose.



Ngaho genda, utazagira uwo umenera ilyo banga cyangwa imana "Wall" izakwihanira. Uraza kunyereka uko wabaze ! ...

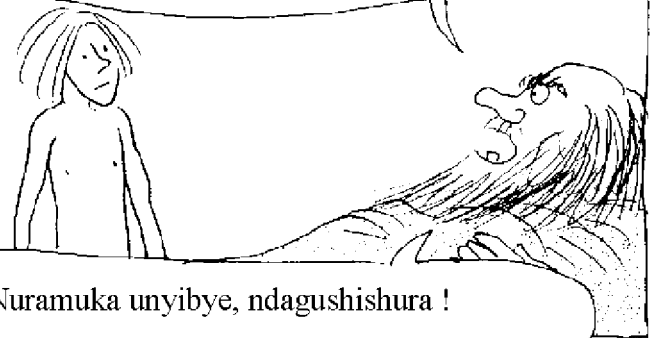

Nuramuka unyibye, ndagushishura !

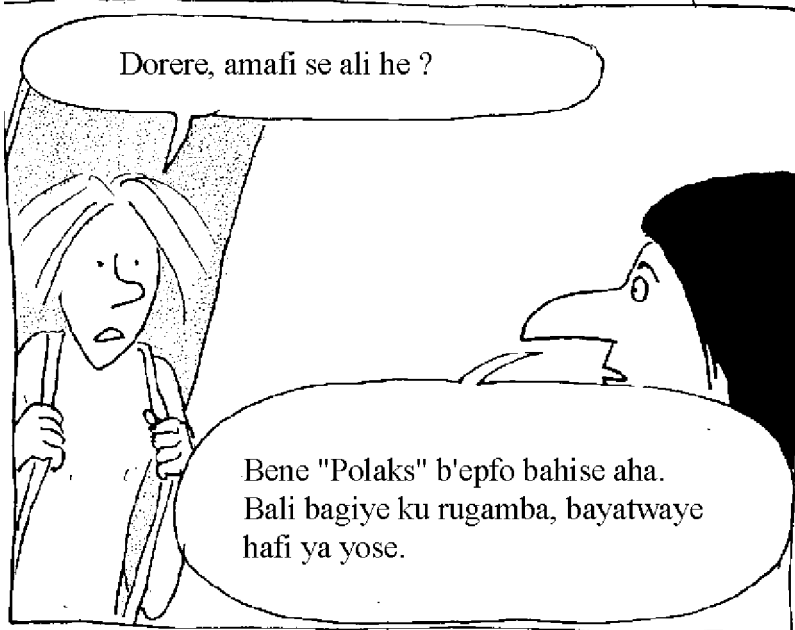
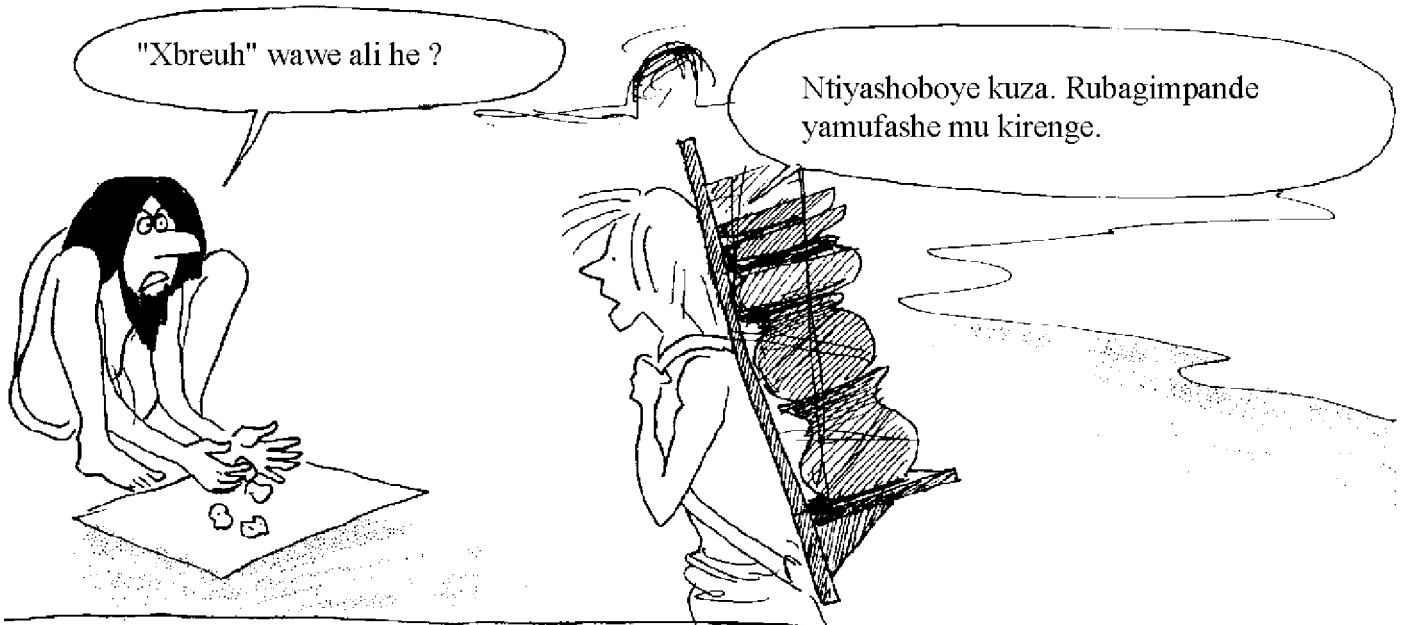

Ngufitiye ibiyaruse. Urabona utu tuntu dukoze mu cyuma ? Rero, buli kose KANGANA ni ifi.

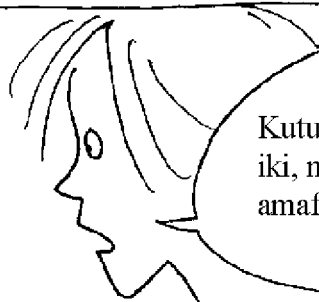
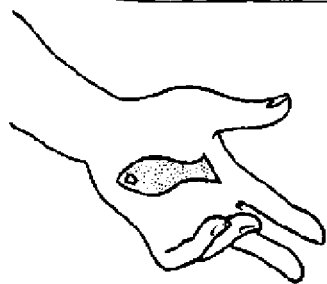

Kutubona ndatubona. Aliko se databuja aravuga iki, nimushyira utwo tuntu aho kumuzanira amafi nya mafi..

Uzi ukuntu utwo dufi twicyuma dushakishwa. Bene " Polaks" b'epfo hali ubwo batunguranira imyaka. Abahigi bazi kudukoramo ubusongero bw'imyambi. Kandi ngo iyo utuyengeshesheje ushobora kudukoramo ibindi bintu byinshi.



Oya, SINTWIZEYE. Ni duto cyane. Ndazagukubitwa.

Uzajya ubara umutungo wawe ute n'ibyo byungo byawe ?
Ubu bulyo bworoshya kubara : ifi, ikintu, ifi, ikintu.

Gutyo ntushobora kwibeshya. Ushobora kudutungamo urunigi : biratuma utaduta mu nzira ! (*)

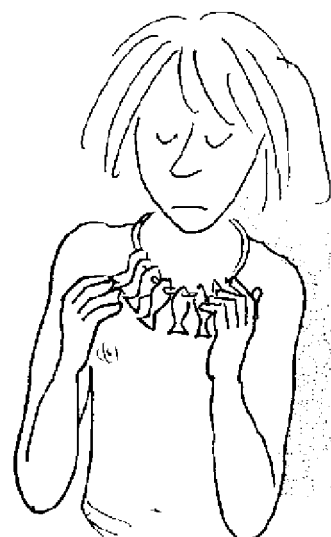

(*) Ubwo bulyo bwakoreshejwe nyuma yaho mu turere tumwe na tumwe two muli "Méditerranée".

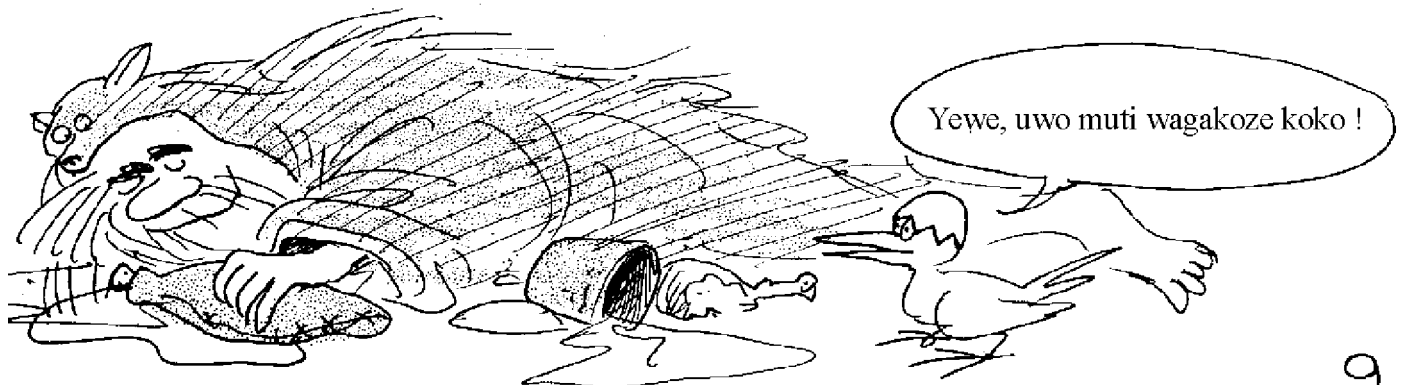

AMAFARANGA atuma bagura bakagulisha ibintu batagombye kuzana aho ngo babigurane ibikoresho cyangwa ibilibwa. Mwene " Xbreuh " akoresha ibiceli kugirango ahindure ibyungo bye mo inyama n'inzoga, akemera kuba abitse ibintu adakeneye vuba aliko bizatuma ashobora KUVUNJAMO ibindi.



Ikiza cyayo, ni uko ataremereye.

IMIBEREHO ISHINGIYE KU IGURA

Nafashe ikiyemezo. Ugiye kubumba ibindi byungo byinshi, umusozi w'ibyungo. Aho kugirango kubigurane amafi nya mafi, uzanzanira utu tuntu, nzatuguramo inyama n'imiti myinshi



Wowe se byakumaliye iki kubumba ibyungo byikubye gatatu ibyo wajyaga ubumba ? Bikubye inshuro eshatu ibyo mukeneye ?

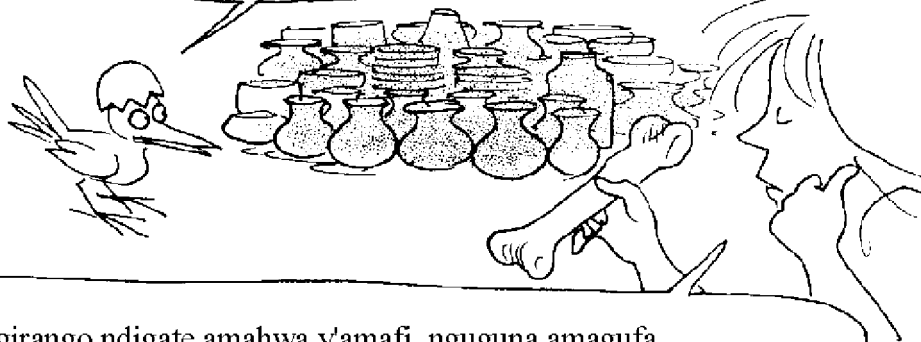

Yewe, aho kugirango ndigate amahwa y'amafi, nguguna amagufa.

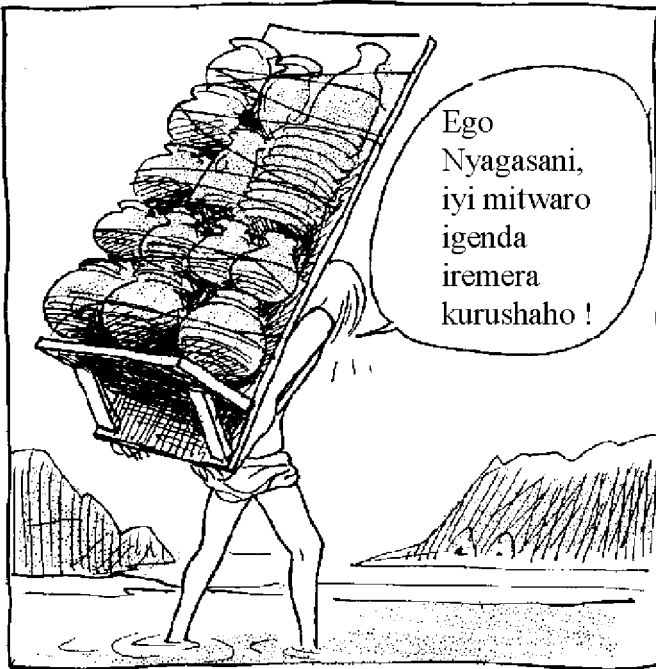

Bene "Polaks" b'epfo barwanaga na bo babonye bose. Baza kurakaza umwami "Numis" arabahagurukana. Bituma atwara igihugu cyose. Yabonye igitekerezo cy'udufi tw'icyuma gishimishije, yigarulira ubutaka bacukuramo amabuye y'icyuma ndetse naho baculira utwo dufi. Ubu niwe wenyine ubifitiye ubushobozi. Ashyira ikimenyetso cye kuli buli gafi.

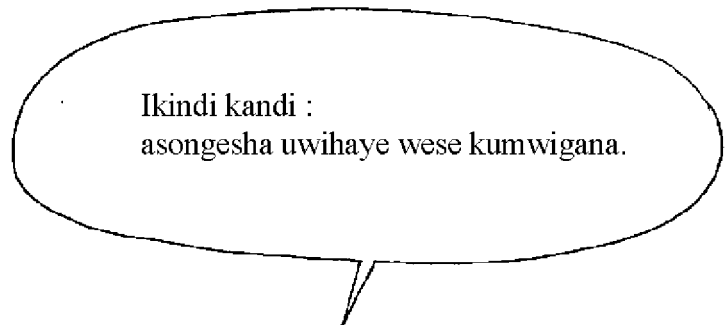
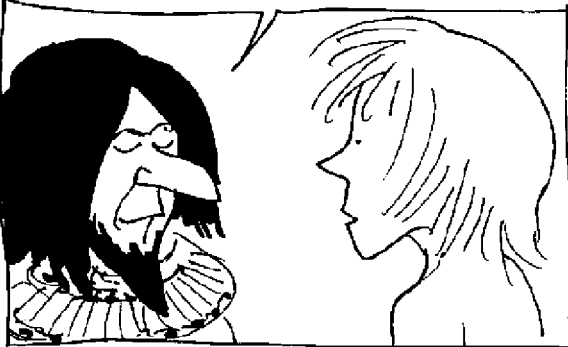

AMAFARANGA Y'IGIHUGU

Kwa mwami "Numis" :

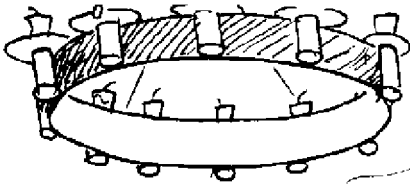

Ubwo buhimbyi bwa bene "Polaks",
ayo MAFRANGA...biratangaje !
Tugiye kugura Isi
yose !



Isi, Nyagasani ?
Isi n'ijuru ! ...

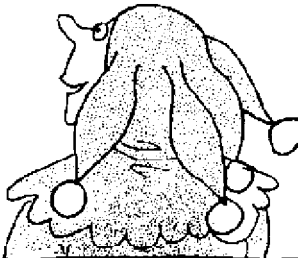

Nibyo koko : reka tugure Isi n'ijuru !

"Sophia" ubucuruza buragenda pe. Ninkubwira umubare w'ibintu umwami "Numis" yatumije ntubyemera. Yiyemeje gutumira abaturage b'Isi yose akaba rero ashaka amafi ishyano lyose.

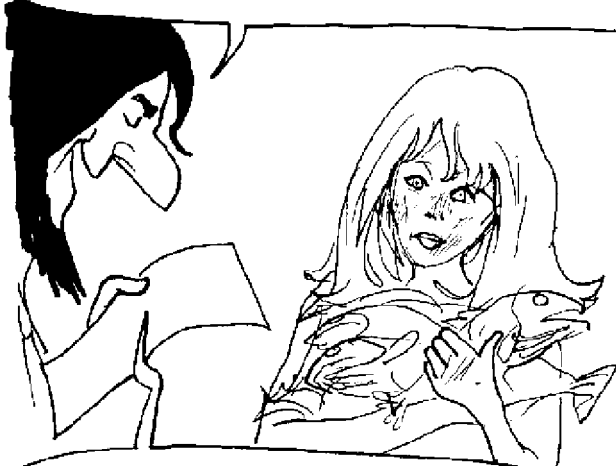

Tugiye kuroba amafi menshi kurushaho.
Uzabohe ubucundura bunini cyane
buzakwira ubuliri bwose bw'ikiyaga.



Hano, muzane amafranga !

Naho "Anselme", abumbira mwene "Xbreuh" w'i "Bordurie" ibyungo ishyano ni shyano.

Ni ikiganza cy'ibiganza by'ibiganza (*)



Uravuga iyi myambi ifite ubusongero bw'icyuma. Erega twujuje imifuka yacu, muvandimwe. Nta kindi dushaka.

Maze kandi ... icyuma n'icyuma ...

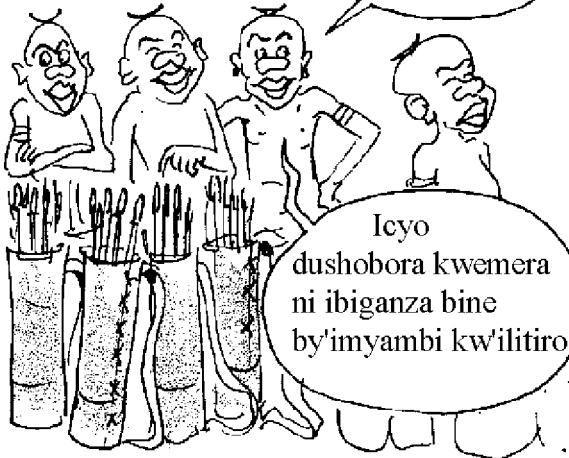

Icyo dushobora kwemera ni ibiganza bine by'imyambi kw'ilitiro

Aliko kwa bene "Tayaks" alibo baheruka ubwo bucuruzi, ...

Reka se, litiro magana abili z'umuti wa rubagimpande ?



Aliko ...nshobora KULIHA ...mfite amafaranga.

Ye...ntaburenganzira mubifitiye. Yali umwambi ku ilitiro! Nshobora kubagumisha kuli icyo giciro !

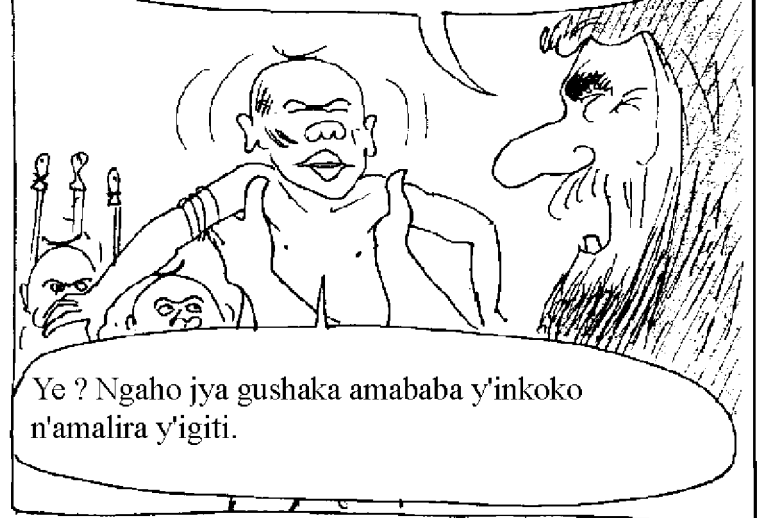

Ye ? Ngaho jya gushaka amababa y'inkoko n'amalira y'igiti.

(*) $12 \times 12 \times 12 = 1728$

(ikiganza gifite ingingo cümü n'ebiyili)

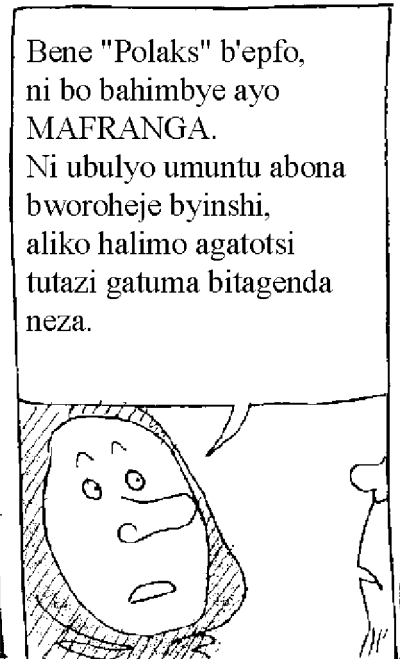
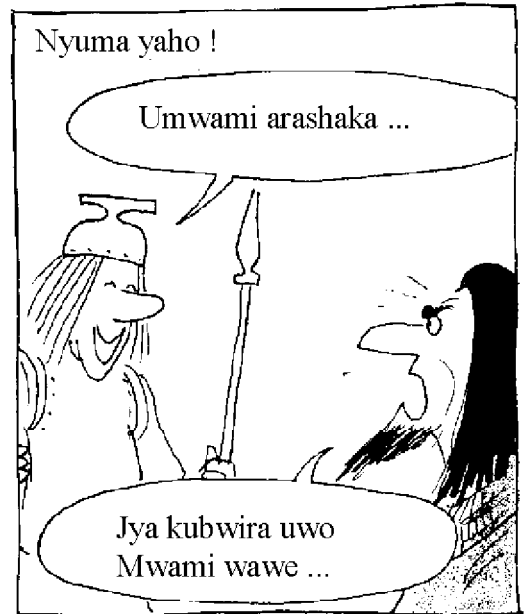
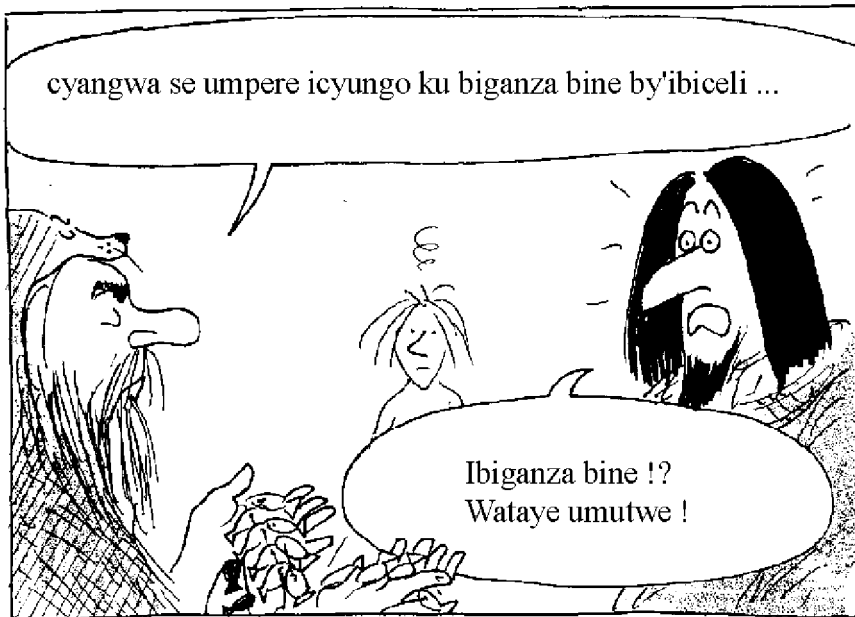
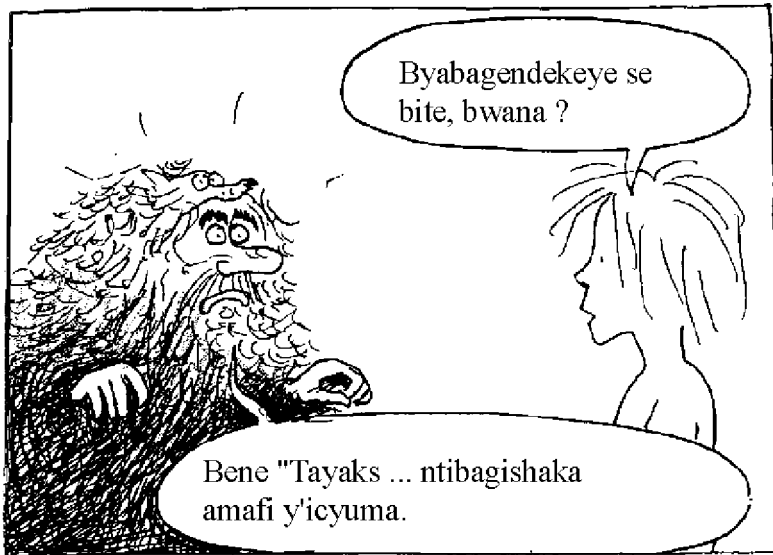



Aliko kwa "Kroumir", ibyo byemezo bihambaye byafashwe n'Umwami "Numis" byateye ibindi bibazo :

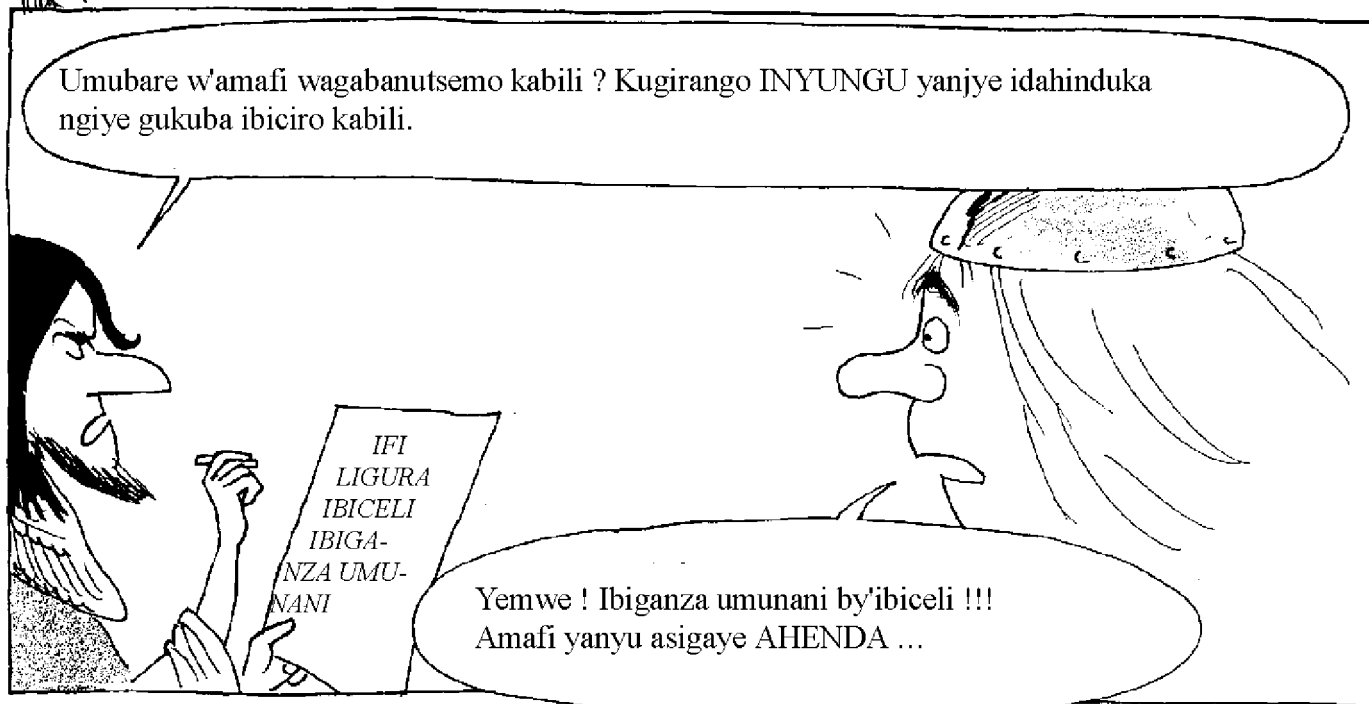
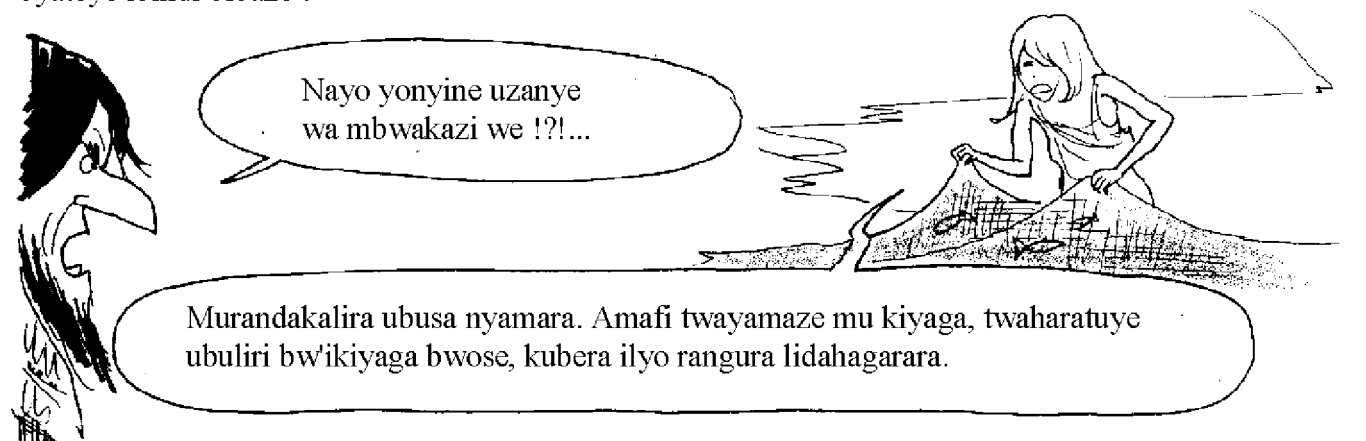

IMBONEKA LIMWE IRAHENDA

Nyagasani, mwabonye ko kubera ko amafi atangiye kubura igiciro cyayo cyilimo kuzamuka. KUBURA KW'IKINTU BYONGERA IGICIRO CYACYO.



Ifaranga lyacu tugomba kuba tutaralihisemo neza. Ibintu by'icyuma bisigaye biboneka ahantu hose. Basigaye icyuma bagikoramo amalingi ya galiyamoshi. Ubucuzi bulimo gutera imbere. Twagombye gukora amafranga yacu mu ibuye LITABONEKA.



Ni ikihe gitekerezo unyunguye?

ZAHABU

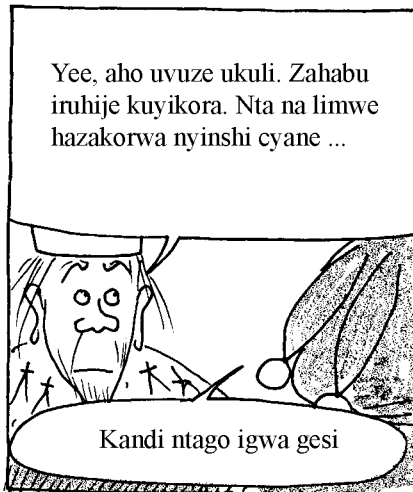

Yee, aho uvuze ukuli. Zahabu iruhije kuyikora. Nta na limwe hazakorwa nyinshi cyane ...

Kandi ntaho igwa gesi



Aliho, hali icyo nibaza : icyo zahabu NTACYO IZAMARA. Ni icyuma cyoroshye.

Kuki mushaka ko igira icyo imara ?

Sinzi ... icyuma cyashoboraga gucurwamo ibintu byinshi byo GUKORESHA : ubusongero bw'imyambi, imisumali, ...



Ibintu bishobora KUGULISHWA

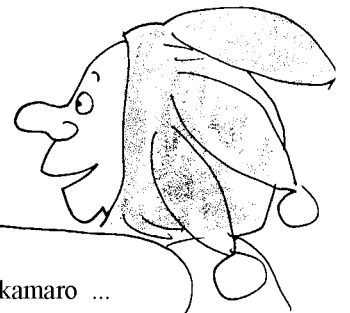

Yemwe, zahabu nayiboneye akamaro ...



Igihugu rero kimara igihe gifite IFARANGA LY'IGICIRO KIDAHINDAGULIKA. Mu igura no mu igulisha, IVUNJA, amafaranga aba aliyo yonyine akoreshwa. ARAHUNIKWA, ARABIKWA bigeze aho AZIGAMWA.

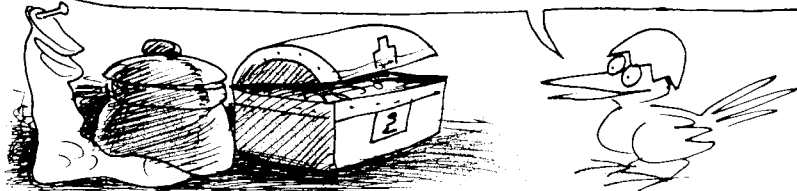

Uko bimeze kose ubucuruzi bukomeza gutera imbere. Mwene "Xbreuh" w'i "Bordurie" yemeza bene "Tayaks" kumugulira ibyungo, aba abiboneye ABAGUZI BASHYA, ISOKO LISHYA.

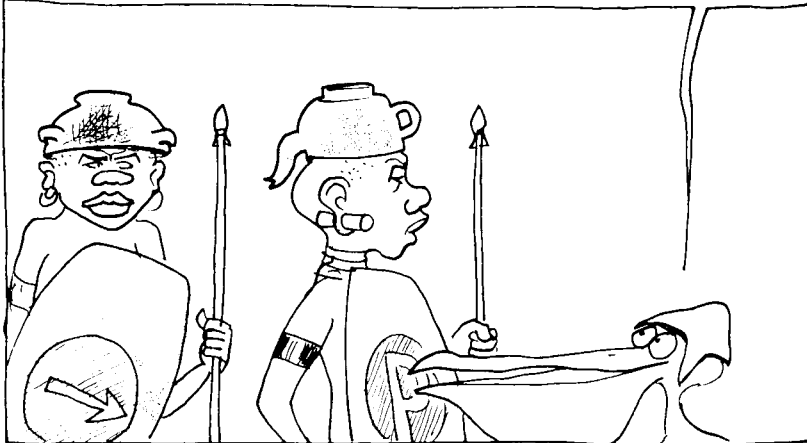

BANKI

Umwami wa bene "Tayaks" yiga nawe umunezero wo kugura, noneho kubera amafaranga yakuraga mu nyama zavuye mu guhiga ashobora kugura ibintu byiza byinshi.



Kubera gutinya ko hagira uwiba amafaranga yazigamwe n'abaturage be, yiyemeza kuyabikisha umuturanyi utagira amakemwa, wemeye kuyabika ahantu yizeye, noneho akamuhembaho make akulikije igihe azayamugumanira.

IZAMUKA LY'IBICIRO LITEWE N'UBWIYONGERE BW'ABAGURA.

Muntege amatwi ! Wowe ugenda nta ngofero, unyagirwa n'imvura , n'ibivuye mu kirere byose, ufatwa n'abazimu bangara, wicwa n'izuba, ambara iyi ngofero y'i "Borderie" izakugira umutware. Gura izi NGOFERO zitaragucika.



HANO TUGULISHA

INGOFERO

Murekere aho kujya gucira amakabutura yanyu ku ntebe z'ishuli. Ingofero yacu y'amaji izabazanira ubwenge bwose mekeneye ihita YINJIZA MU MUTWE.



"Anselme Lanturlu" mureba aha, yali umuswa mubi, yigishijwe IBANGA LY'INTOKI ni iyi NGOFERO.

Ego, mwene "Xbreuh" nta muntu atinya mu MATANGAZO.



aliko se ntutekereza ko ...

Ufite mu mutwe hazima !?!

"Anselme", mwana wa, ubucuruzi buragenda kubulyo buteye ubwoba !



Amagilibari mirongo itanu, muvandimwe !

Bwana, hasigaye eshatu gusa!

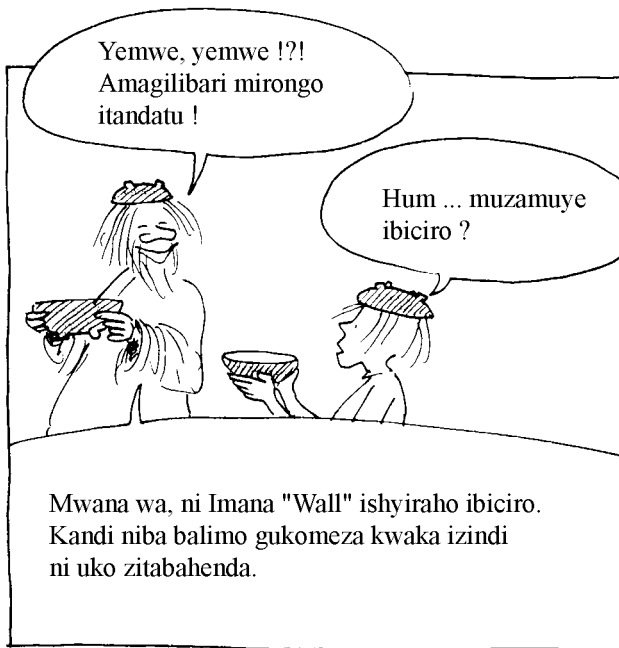

Anselme, ibintu byose nabiteguye. Kuva ubu tuzajya twokeshya ibyungo aya mavuta y'umukara, iyi mazutu.

IZAMUKA LY'IBICIRO LITWEWE
N'IHENDA LYO GUKORA IBINTU



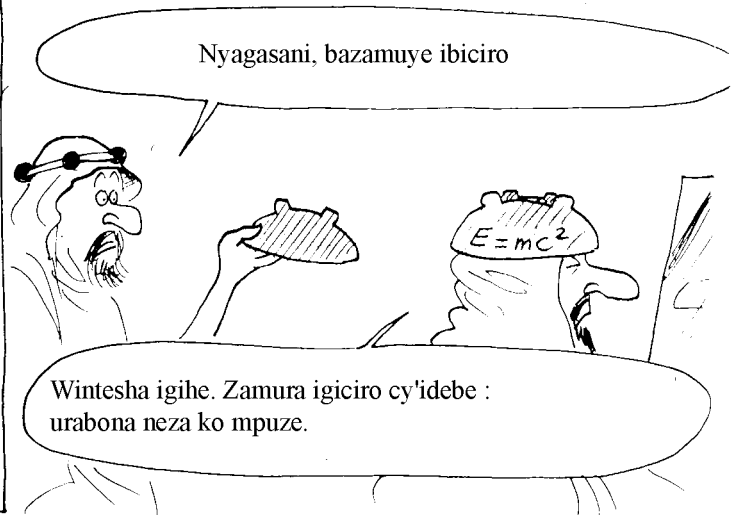
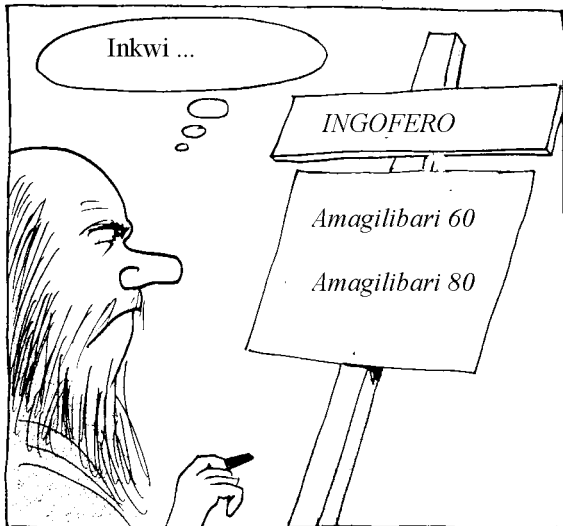
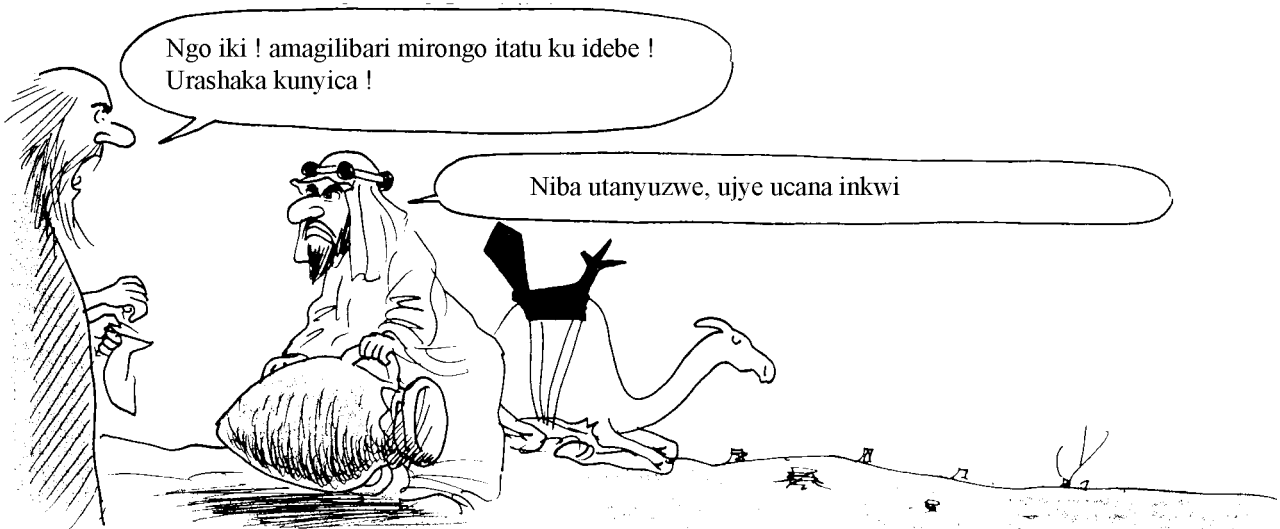

Umunsi umwe ...



Aha, ndabibona. Ni uliya mukobwa ukora ku kiyaga wagushyize mu mutwe ibyo bitekerezo ! ...

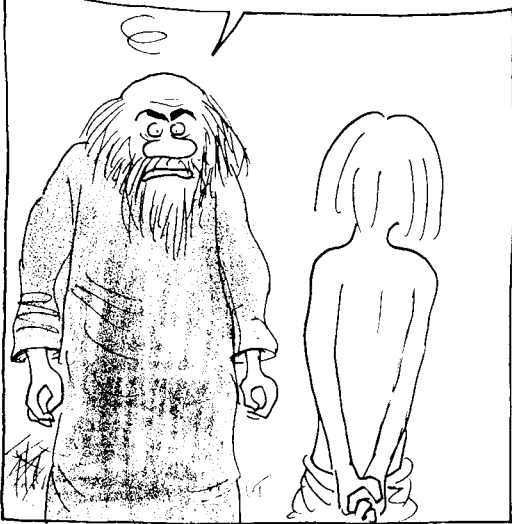

Ngo iliya bashinze "Koperative" cyangwa ikindi kintu nk'icyo !



Ndashaka amagilibari atanu ku muni ...

... n'umuni w'ikiruhuko mu cyumweru

Urashaka gusenya urugo ? Ngomba kwishyura mazutu kandi igiciro cyayo kirakomeza kuzamuka !



Nimugabanure kunywa... umuti !

Amagilibari atanu ku muni ! Urashaka ko mpfa !

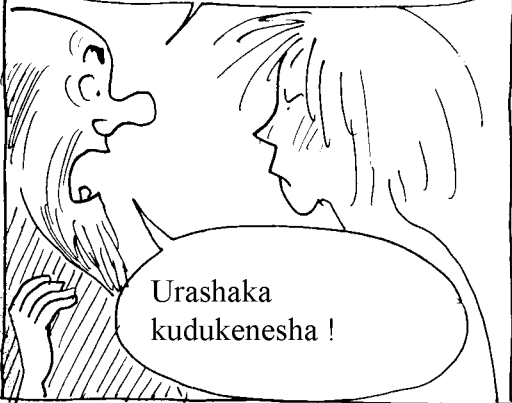

Urashaka kudukenesha !

Amagilibari atanu ku muni



Ego "Wall" ndimokurota, ni inzosi mbi.

Umva, nukora cyane, cyera nzakugororera ...

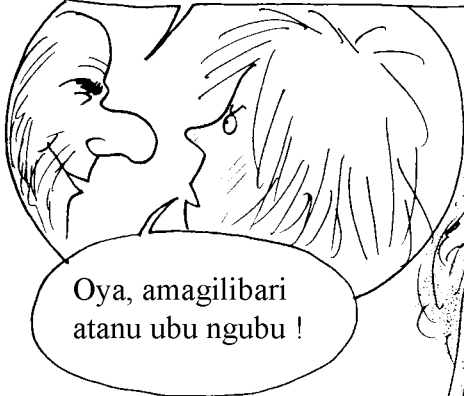

Oya, amagilibari atanu ubu ngubu !

Aliko se urasha kugura iki mu mafaranga angana atyo ?



Nzaguramo ishata n'isabune !

Aha, ni ibyo ! Urashaka kwigira umusilimu,
ejo uzabe wabaye ibandi, ejo bundi indaya !

Sinzatuma ubwawe wihemukira !

Wintesha umutwe ?!!
Njye icyo nshaka
ni ISHATI !



Niba ali ibyo,
ibyungo byawe uzage
ubyibumbira !

Nshinzwe imitwalire yawe
imbere ya "Wall"

Mbega ubwiture buke !
We ungomba byose, nagabuliye ...



Hum, agati
kanjye !



Kare mu gitondo :

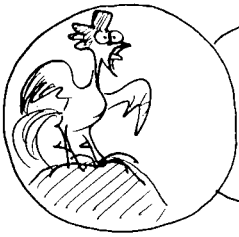

Anselme, manuka vuba aha !
Ugomba kubumba ingofero
z'aba "Broutchiens". Bazaza ejo.

Ndashaka amagilibari
atanu ku muni n'umuni
w'ikiruhuko mu cyumweru !



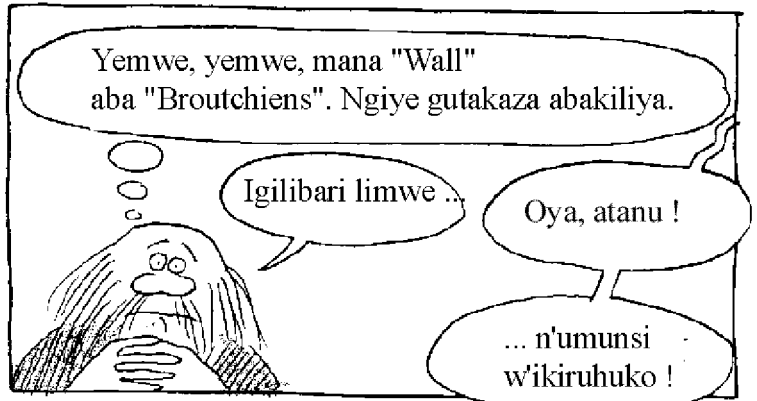
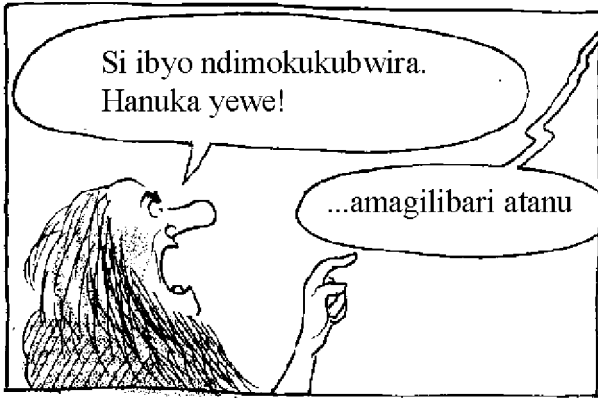

IRUSHANWA

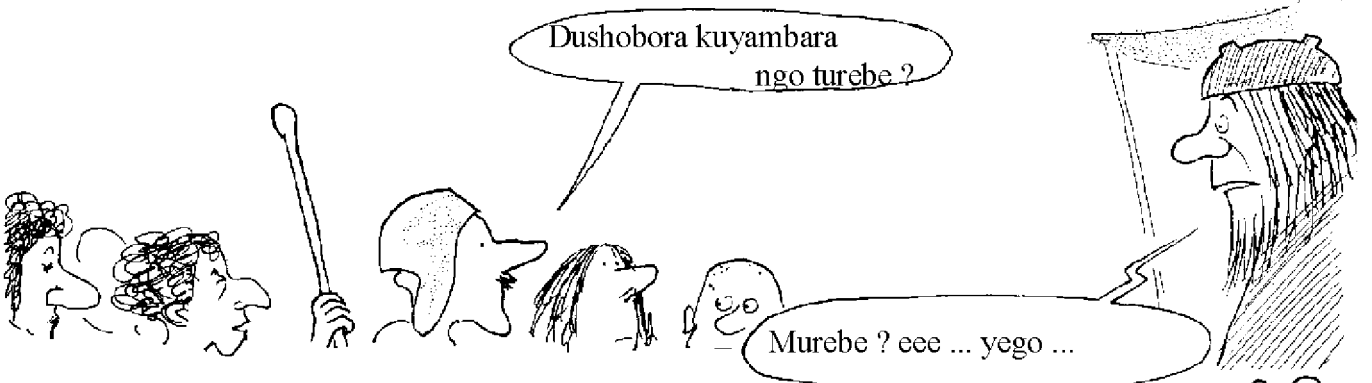
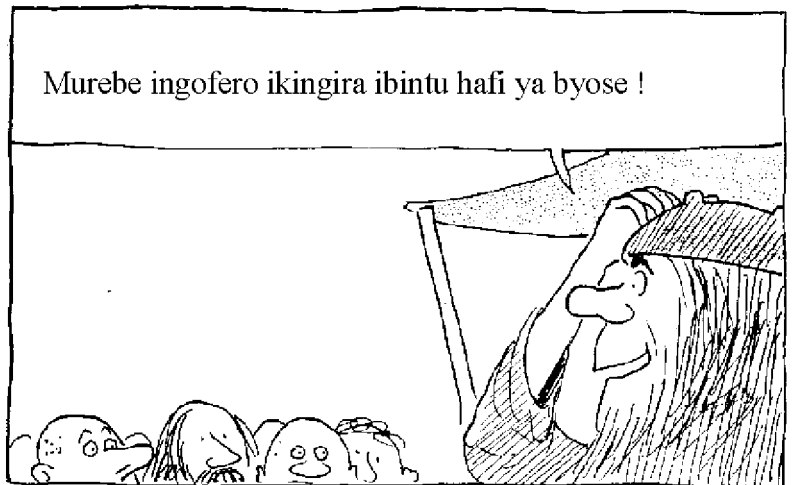

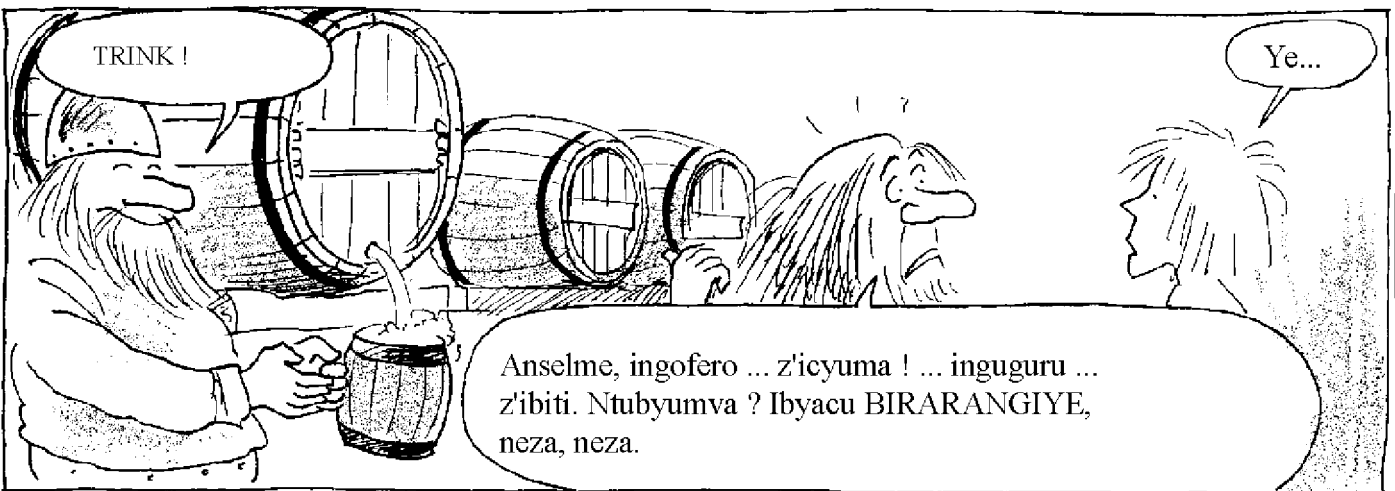
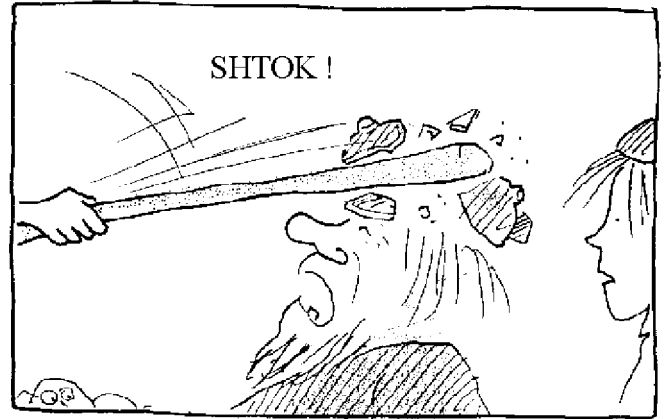

Ubwo buvumbuzi, ubwo BULYO BUSHYA BWO GUKORA bwica ubucuruzi bwa bene "Xbreuh" w'i "Boderie" mu gihe gito...



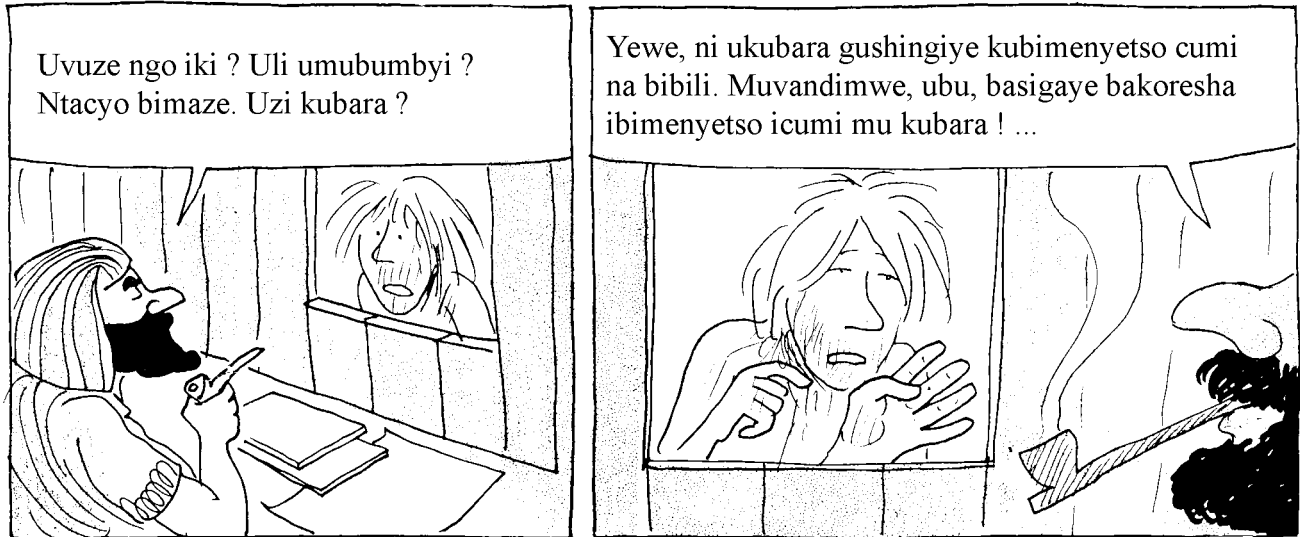

Uvuze ngo iki ? Uli umubumbyi ?
Ntacyo bimaze. Uzi kubara ?

Yewe, ni ukubara gushingiye kubimenyetso cumi
na bibili. Muvandimwe, ubu, basigaye bakoresha
ibimenyetso icumi mu kubara ! ...

Muli ubu bulyo bwinshi bushya, ntawe ugikulikira.



Mu gihe Lanturlu ali mu nzira y'ubutayu y'UBUSHOMELI, ku nkombe y'ikiyaga, Sophia :

MATKOBOWSKA ! Kuva twica "Kroumir" tukigarulira ikiyaga,
kugeza ubu, byagenze bite ?

Twe, abarobyi twarakomeje turagakora. Nyuma yaho, tubona
hagobotse abanyunyuzi b'imitsi y'abandi ilyaguye, none imibereho
yacu ntacyo yungutse.

Koperative yacu ni nziza !

Muvandimwe, ntugomba kuvuga utyo. GUKORERA HAMWE ni intambara. Ni ugushora urugamba hejuru y'ibyo abantu bagezeho (imyaka basaruye, ubikoresho babumbye, bacuze, ...). Abandi barwanira hejuru yo kigira umutima nama wa POLITIKI n'UMUTEGANYO w'ibizakorwa. Muli iki gihe UBUKUNGU BW'IGIHUGU BURATEGANYWA (*).

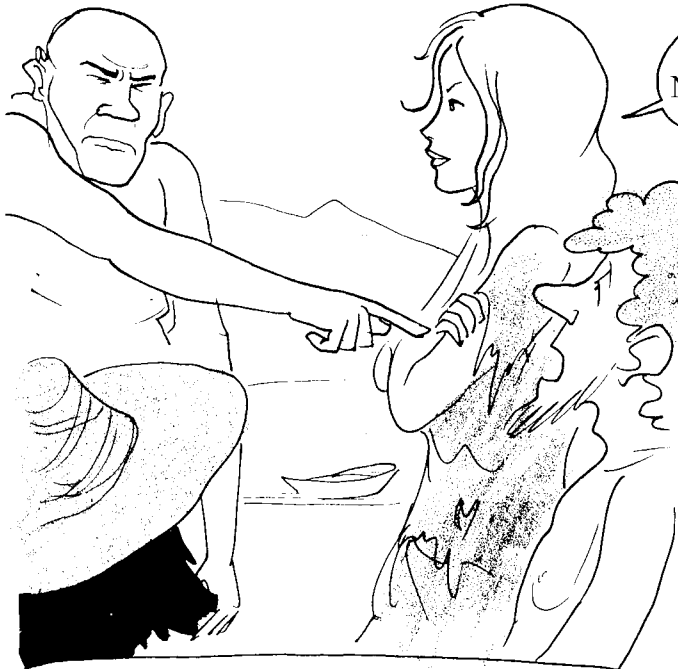

Ngwino, ngwino urebe izo mena zawe za politiki !

Barebe uko bilirwa bihereza barangiza bagasinzira !

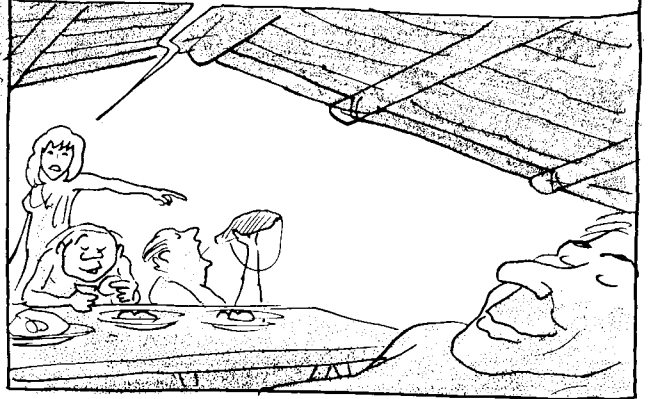

Ntabwo balimo kulya, barasogongera. Balimo kumva niba ibyo bilibwa cyangwa ibinyobwa bikulikiza amategeko agenga uko bigomba kuba bimeze.

Tubayeho neza kurushaho dushyize hamwe. Nta shomaje. Buli wese afite akazi.



Ngo barareba ko bikulikiza amategeko ? Winsetsa !



Nta bakire bakiliho.

Niba hali umwe ukora nyagukora, abandi icumi baliyicaliye cyangwa barasinziliye.

Utamwisukira Sophia, ni uwa sekilite ashobora kukugilira nabi

Ibyo byose mbizi mu mutwe. Ko ibintu bihinduka, narabishakaga rwose.
Tumaze kwica Kroumir sinamuliliye.
Aliko se uzabigira ute kugirango abo bantu bose batongera
kwitoramo imbura mikoro, abanebwe n'ibigolyi, ahubwo bagumye
kuzilikana politiki ... Ese ubundi kuki bafata imilizo y'amafi twe
bakaturekera imitwe ? Kuki halimo ilyo BERERWA ?

Ibitekerezo byawe bya kera bilimo kukubuza kubona ukuli. Ugomba kubirebera limwe
byose aho kugirango ugende uninjura buli kantu.

Inyuma yiliya misozi i Borderie hali
abantu bafite ABAGARAGU

Aha, noneho ino biraculitse !

Birakabije ! Ngiye kugukorera raporo ! ...

Kuli data w'abaturage !

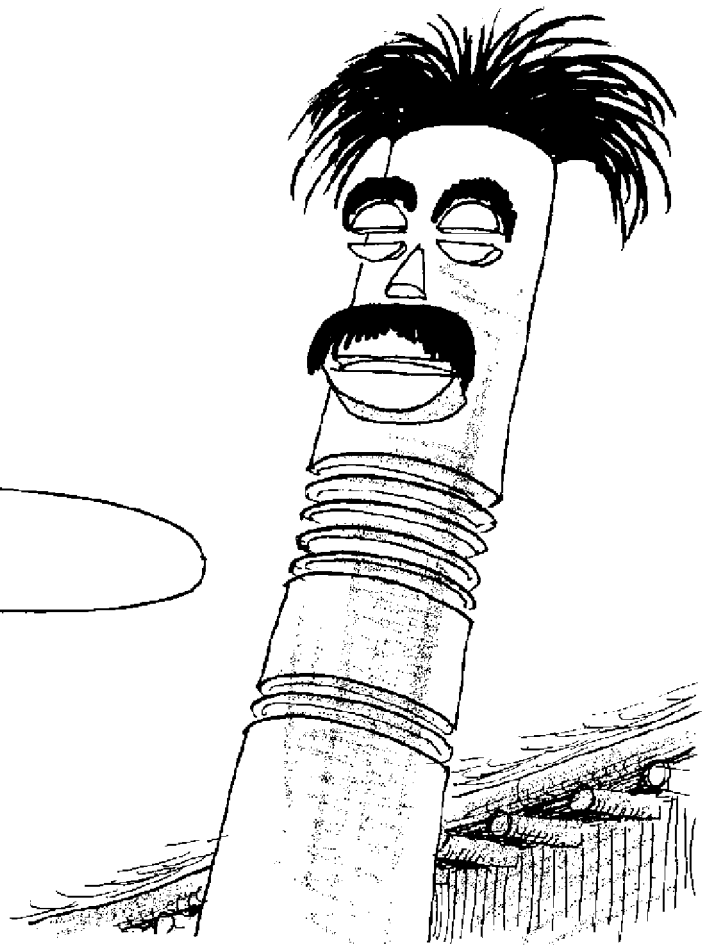

Kwa Mwami Noumis :

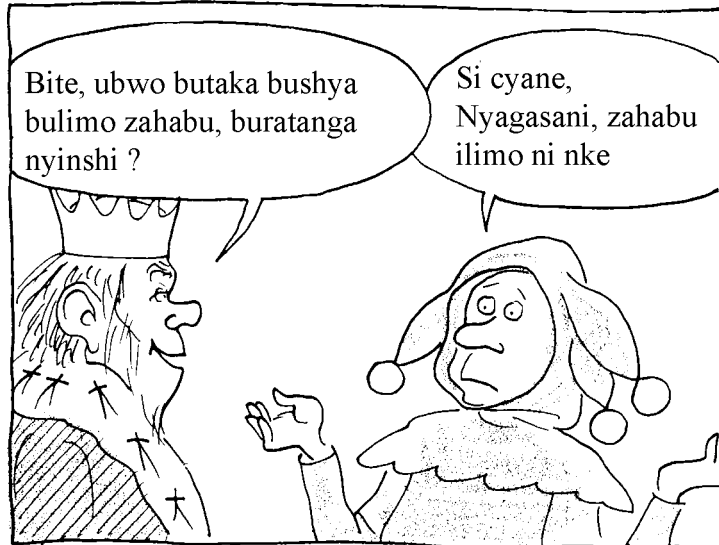

Bite, ubwo butaka bushya bulimo zahabu, buratanga nyinshi ?

Si cyane, Nyagasani, zahabu ilimo ni nke



Nibyo ! Ni ikibazo. Dukeneye cyane amafaranga hagati aho

Sinshaka ko hano naho bizatugendekera nko mu karere ka Kroumir k'iburasirazuba.

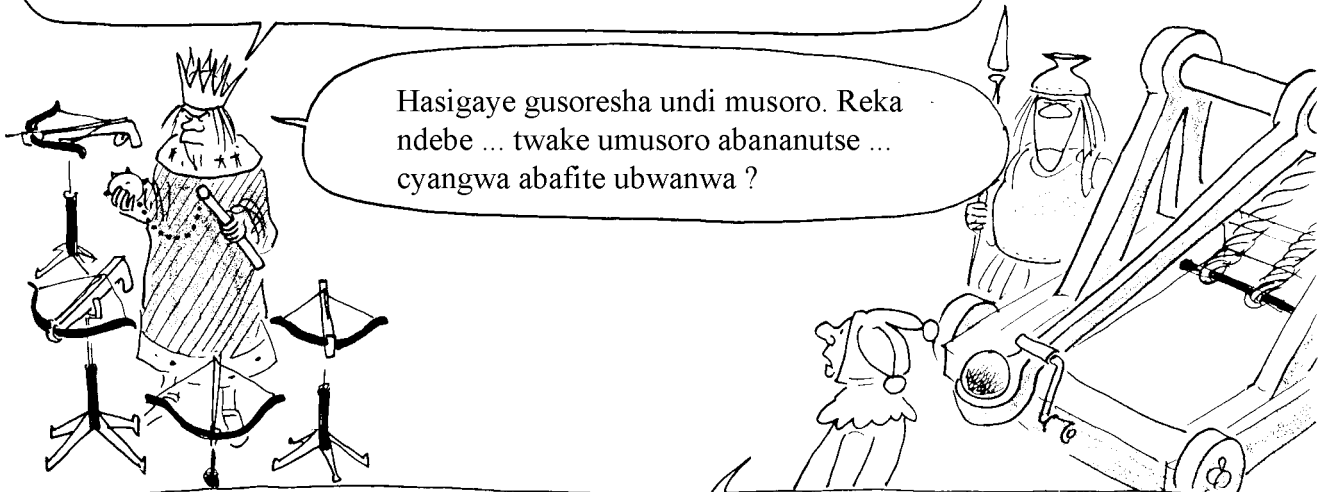

Hasigaye gushyirira undi musoro. Reka ndebe ... twake umusoro abananutse ... cyangwa abafite ubwanwa ?

Nyagasani, ntabwo ibintu nk'ibyo bigishoboka. Byafatwa nabi. Kandi ntidushobora kongera ku gabanura umubyimba w'ibiceli bya zahabu, byasigara bibonerana.

Umva, ntuli umucunzi w'ubukungu bwanjye ? Ni wowe ugomba kubona ubulyo bwo kubambura mu mayeli kubulyo batabibona. Niba utabishoboye ndagusongesha !



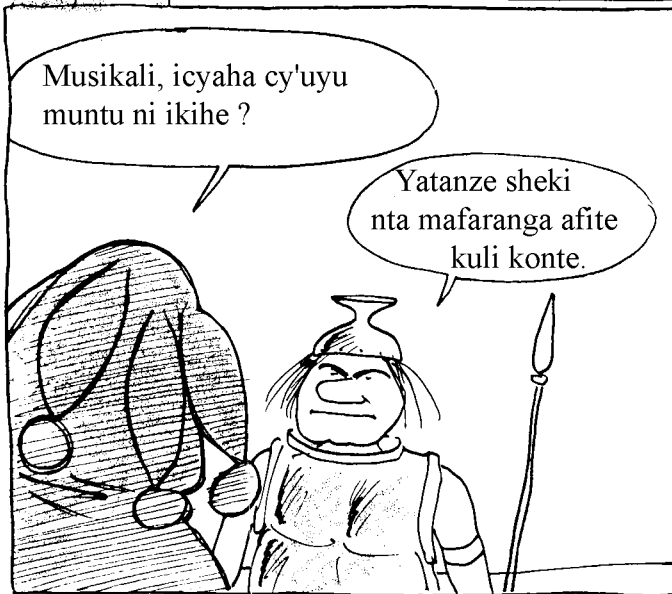
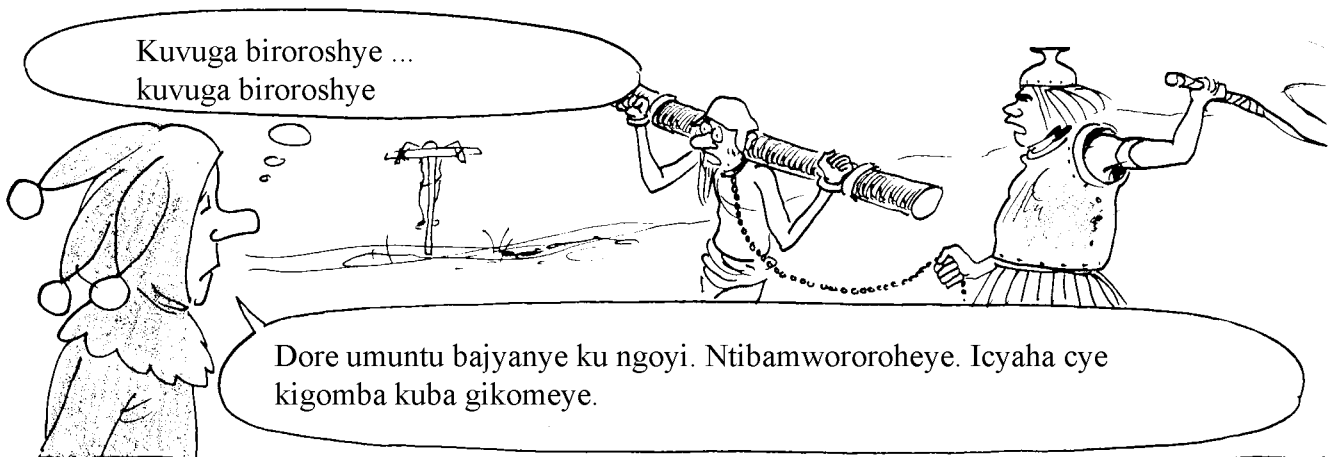

Nuko rero hali abatekereje ubundi bulyo. Bandika ku gapapuro ko kemewe ku ma gilibari aya n'aya maze bagashyiraho umukono wabo. Utwo dupapuro nitwo bita sheki. Birumvikana ko amategako abuzza gutanga sheki ziruta amagilibari umuntu afite mu mwobo we, muli banki, igihano ni urupfu. Ushobora kugura ibintu utanze utwo dupapuro.

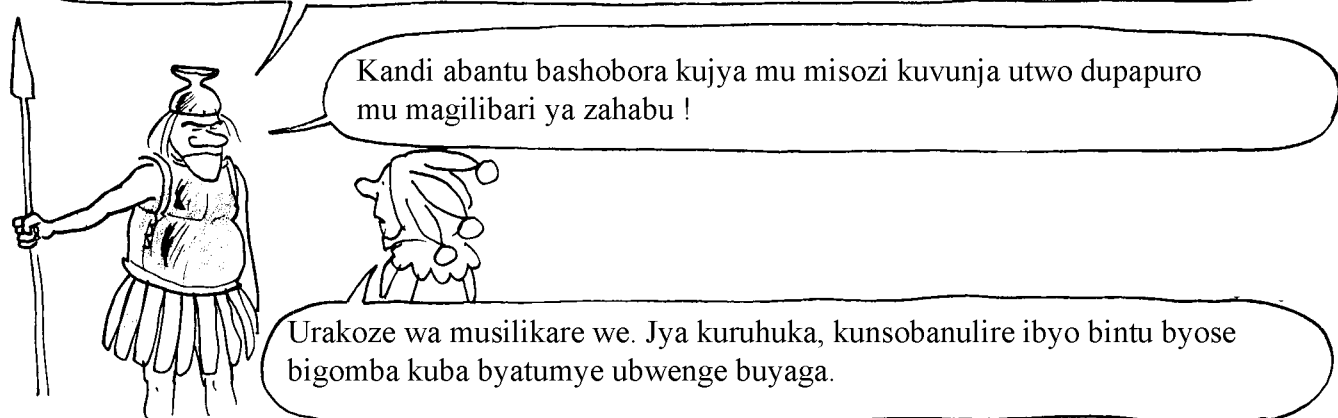

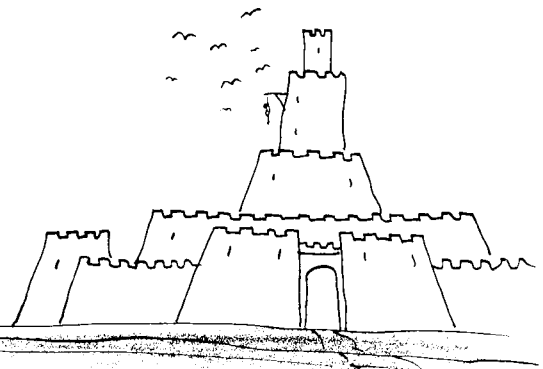

AMAFARANGA Y'IGIPAPURO

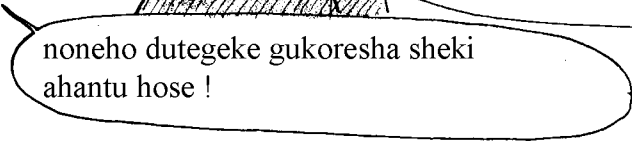
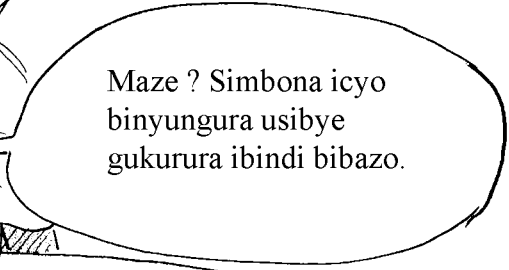
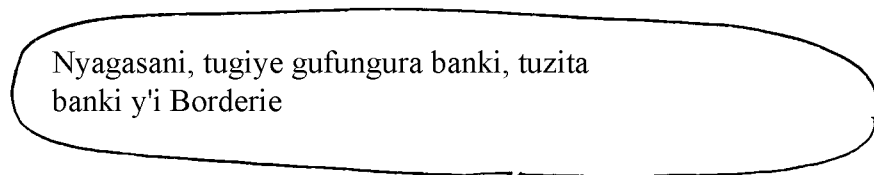

Tuzabanza twakire zahabu y'abaturage bose muli banki yacu. Nibiba ngombwa tuzabasunika ... Noneho twe tubahe impapuro twanditseho amagilibari aya n'aya. Tuzakora kubulyo ntawe uzongera gukoresha ubundi bulyo agura.

Aliko ... ntabwo bizatugira abakire kurushaho !?

Aha, buretse, banza ntangiye kubyumva

Natwe tuzatanga izo gilibari z'impapuro. Zizaruta ubwinshi kure gilibari za zahabu.

Hum ... byali bitangiye kugaragara ko gilibari za zahabu zacu zalimo guta agaciro., aliko se ninde uzamenya ko alitwe dukora ayo **AMAFARANGA Y'IGIPAPURO ?**

Izaba inkuru ya mbere y'amasheki atagira amafaranga kuli konte.

Amafaranga y'ubuhendabwenge !

...Ikosa ! ...

Hmmm ?! ...

Oo, ntacyo mvuze, Nyagasani, ...

Buretse gato : nidukora amagilibari y'igipapuro menshi, abantu baba ibigolyi bagira bazabyibazaho. Kandi amagibari y'igipapuro naba menshi, menshi cyane, akaruta ubwinshi amagilibari ya zahabu, tuzananirwa kuyavunjira limwe, igilibari imwe y'igipapuro kuli imwe ya zahabu, kugirango akomeze KUNGANA.

Aliko : nshobora kwanga kuvunja ...

Nyagasani, ibyo bishobora gutuma abantu bose bata umutwe : abantu ntibongere KWIZERA AMAFARANGA Y'IGIPAPURO yacu.

Nidukora amagilibari y'impapuro akubye ubwinshi kabili amagibari ya zahabu, dupfa kuvunja ebyeli z'igipapuro kuli imwe ya zahabu.

Mbonye uko tuzabigira : abantu nibamara kutuzanira gilibari za zahabu zabo, tuzaziyengesha !

Byaboneka nabi, Nyagasani ...

Maze se bitange iki ?

ZAHABU gusa ...

Indurubuli y'amasheki atagira amafaranga kuli konte yatangiye atyo mu mateka y'iyo Ngoma. Ibintu bigenda nk'uko bali babiteganyije. Abantu bazana amagilibari ya zahabu yabo, ahita avumbikwa ayengeshwamo zahabu, nti hagira uwongera kuyumva. Umwami Numis yandikisha inote ishyano lyose, abantu bihutira kuziguramo ibintu hilya no hino. Birumvikana, ibiciro birazamuka kimwe na zahabu. Aliko kuko byose byahendaga nti hagira uwongera kumenya ifaranga lya kera ly'i Borderie ...

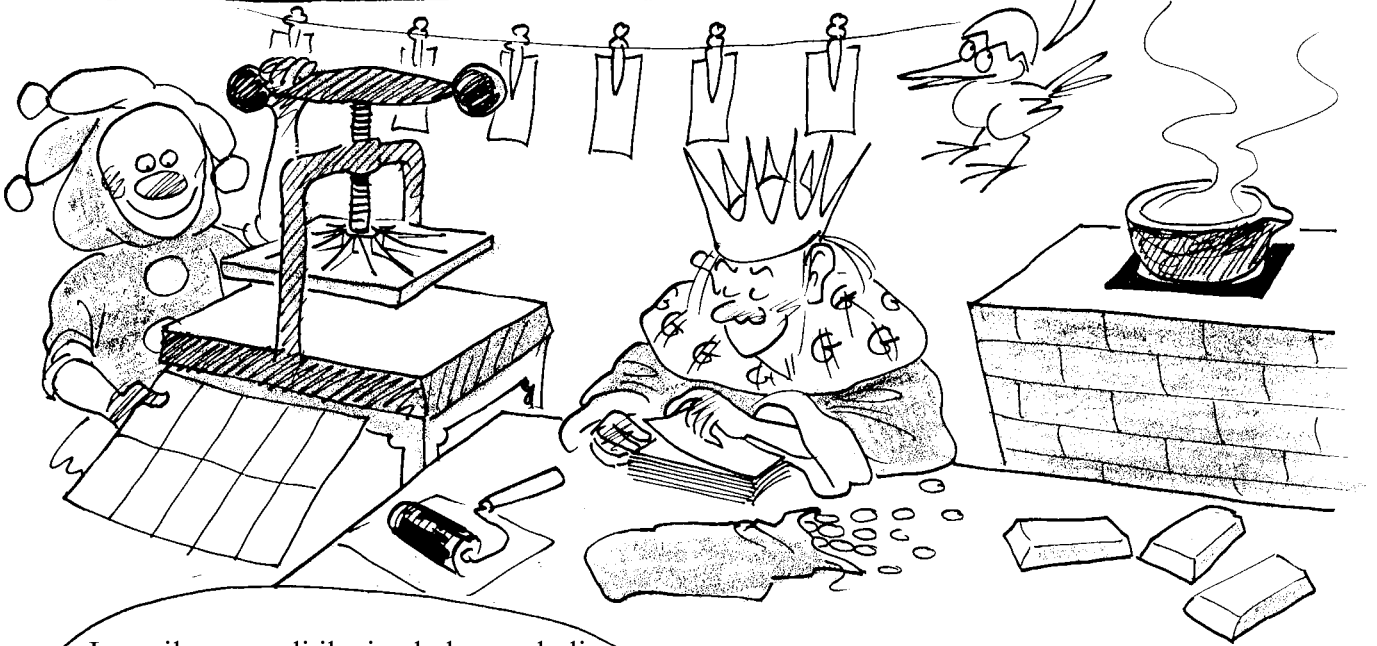

Iyo mikorere yali ikwiye kohereza buli munya "borderie" wese mu munyururu bayise **UBUKUNGU BW'IGIHUGU**.

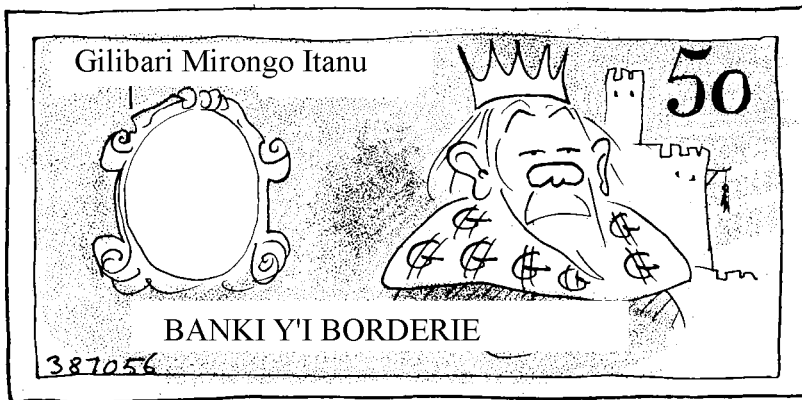
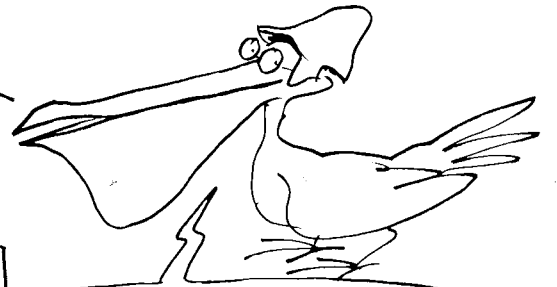

Nkuko byumvikana Numis acira urwo gupfa abashatse bose kwikorera ku giti cyabo **UBUKUNGU**.

Mbere yo kugirango abantu bafate amafaranga, bagombaga kuliha imisoro myinshi



Numis akomeza guca imisoro, aliko kubera ko yashoboraga kongera uko ashatse AMAFARANGA Y'IGIHUGU, nta na limwe yigeze abura amafaranga y'igipapuro yo gukulikira IZAMUKA LY'IBICIRO yali yarateye. Hagati aho ibiciro bikomeza kuzamuka, kuzamuka.



Aliho imikorere izana ubukungu i Borderie yali yinjiye mu GIHE CY' INGANDA kandi ilimo guteraimbere. Mu gihugu cyose bubakaga inganda, abanya "borderie" bakoramo ali abakozi bahembwa. Inyinshi ali iza Numis n'umulyango we, baguze ... amafaranga y'igipapuro.

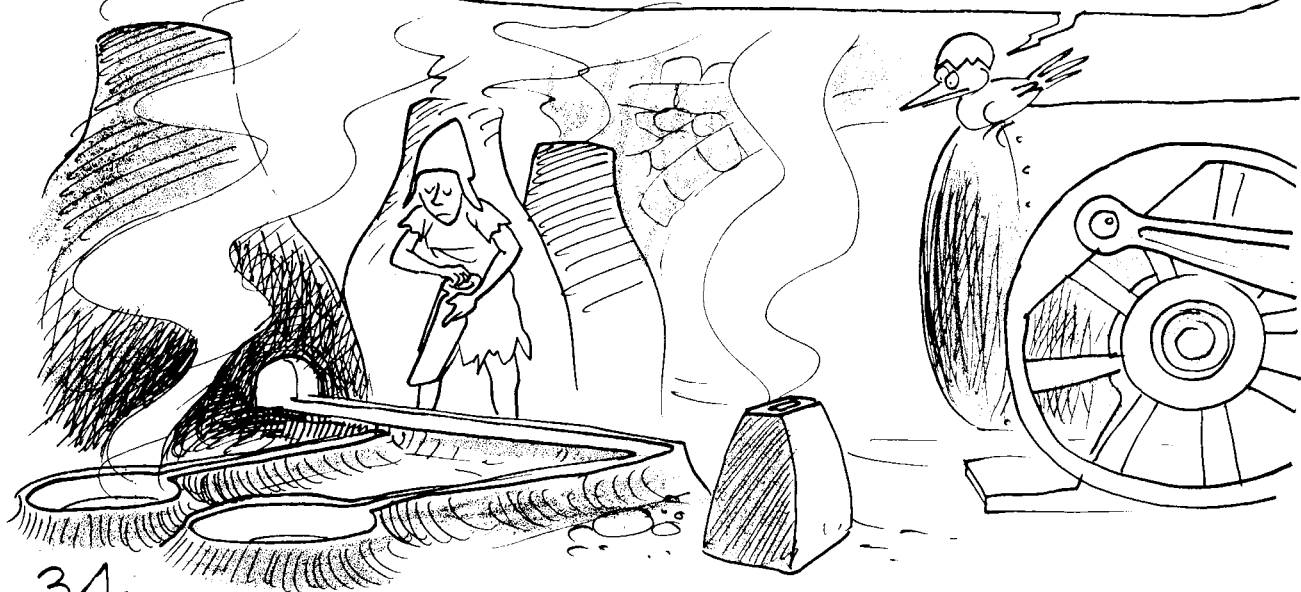

Kubera izamuka ly'ibiciro abakozi baka ko imishahara yabo yongerwa.
Nuko, limwe na limwe bakigaragambyana amahane :

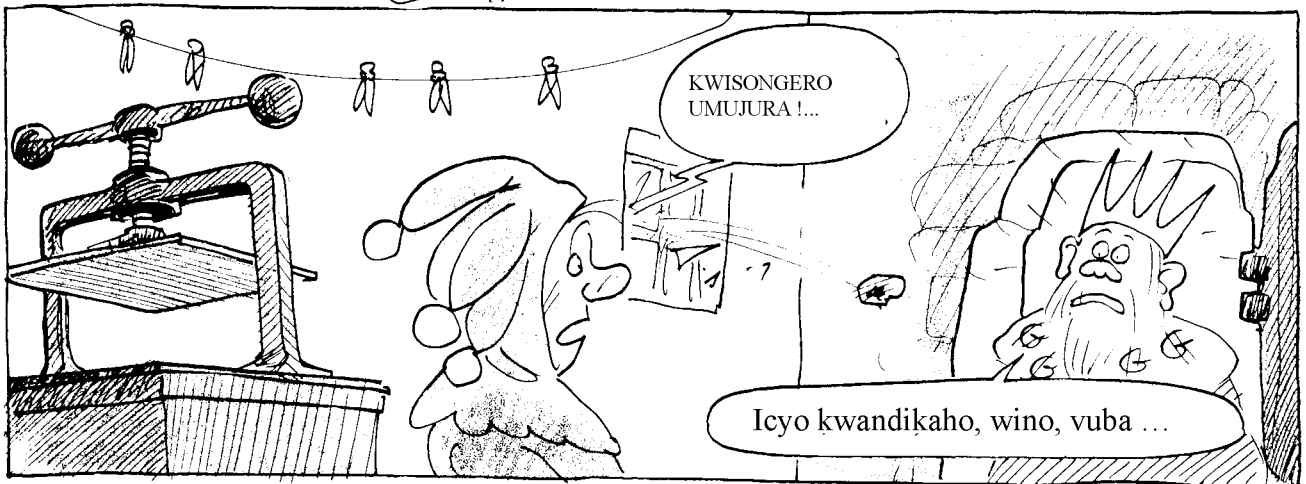

Mu gihe gito, byatumaga abantu biyibeshyamo abakire

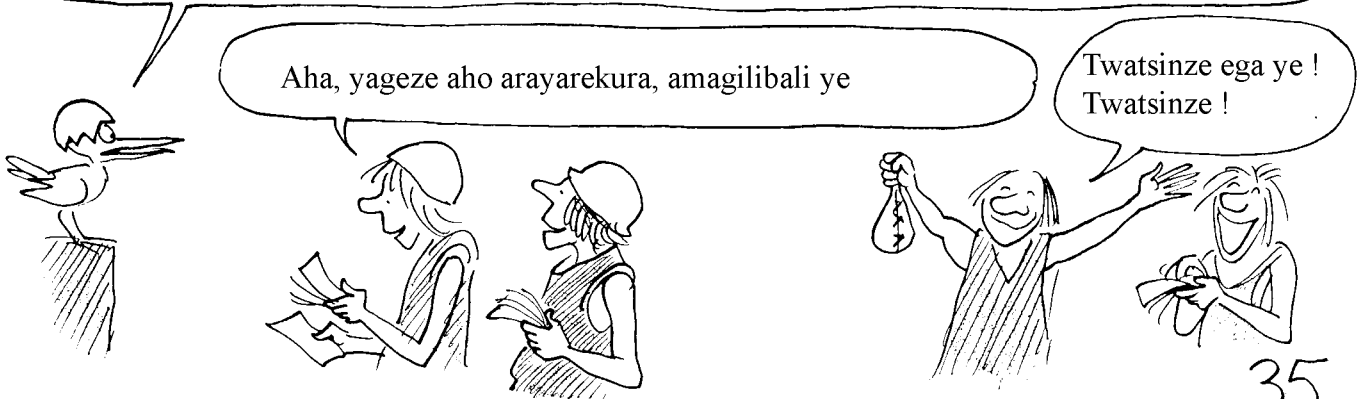

Abantu bihutira mu maduka kugura ibintu



Kugirango yizere KONGERA INYUNGU ye, umucuruzi nawe, ni mugoroba akazamura ibiciro

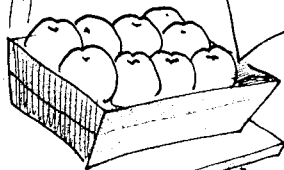
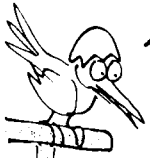

~~800 G~~
900 G

Niba bakomeza kugura ni uko bidahenze bihagije, kw'izina lya "Wall" !

Ugomba kongeraho n'umushahara w'uyu twagombye gufata ngo adufashe



Uko bihinduka, niko mbona ali ha handi, ali kimwe.

Simbyumva !

Amagilibali magana abili ! Mu myaka icumi ishize nahembwaga atanu !

Aliko se wabonye ibiciro ?

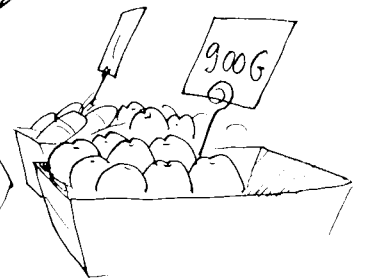

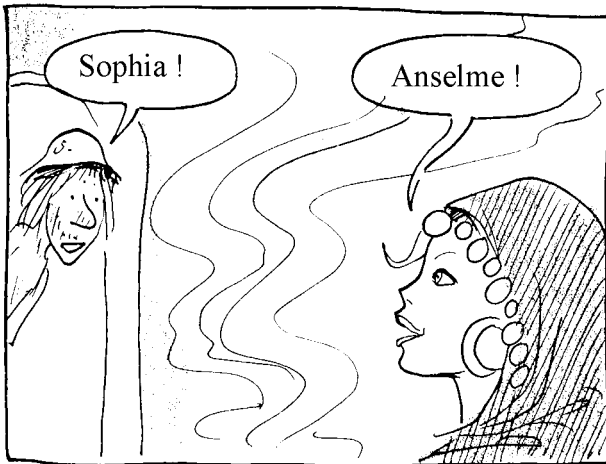
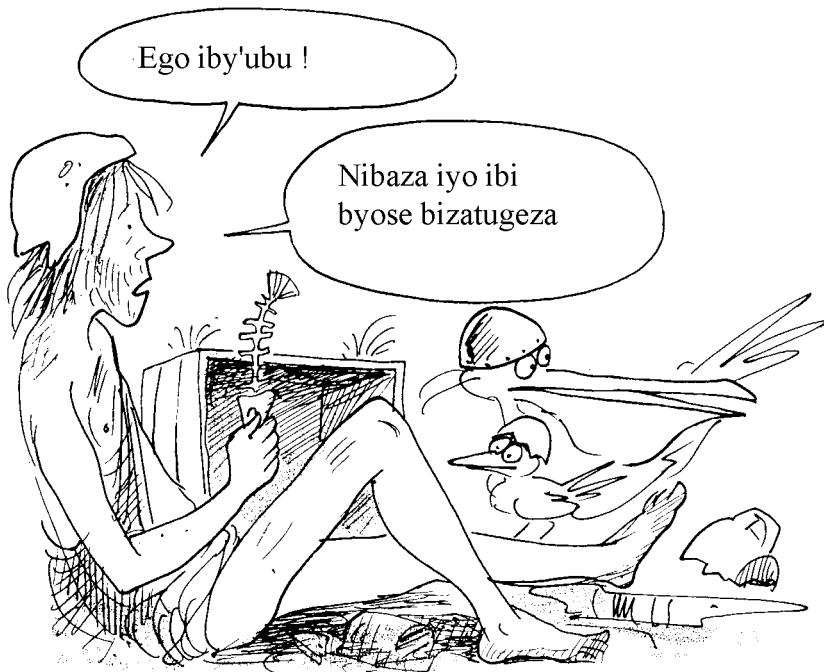

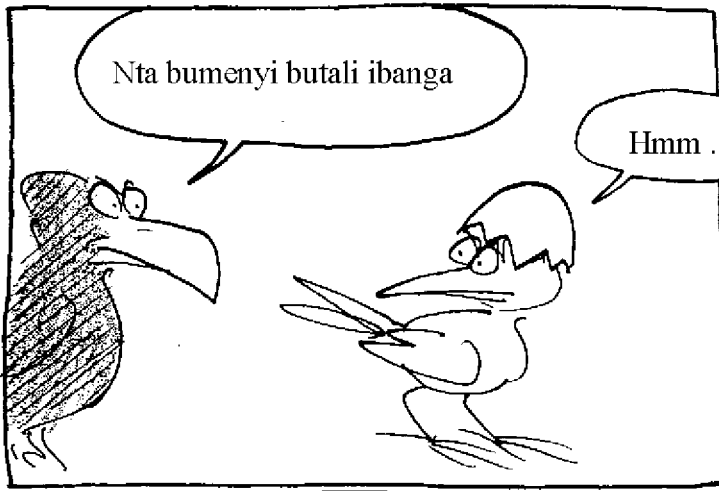

Nta bumenyi butali ibanga

Hmm ...

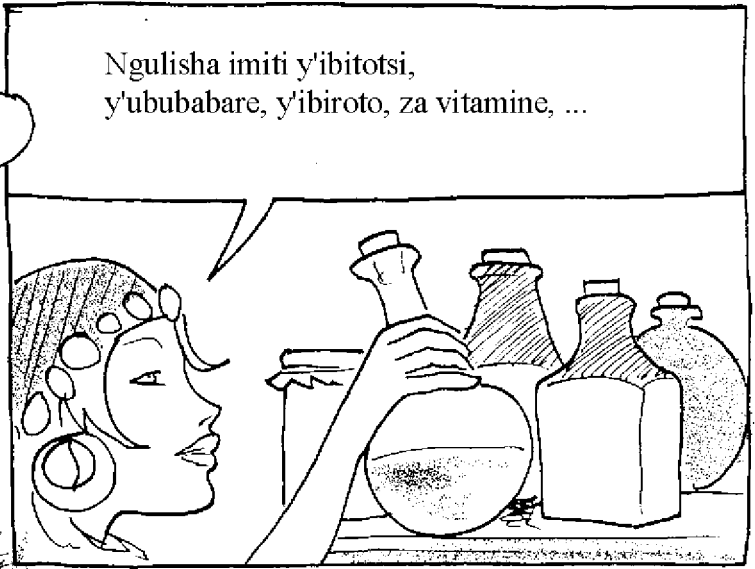

Ngulisha imiti y'ibitotsi, y'ububabare, y'ibiroto, za vitamine, ...



Bikagenda se ?

Ntacyo mbaye ... mu nzara, igihe abantu baburaraga naronse amagilibari ibihumbi magana atandatu.

Gilibari ibihumbi magana atandatu !

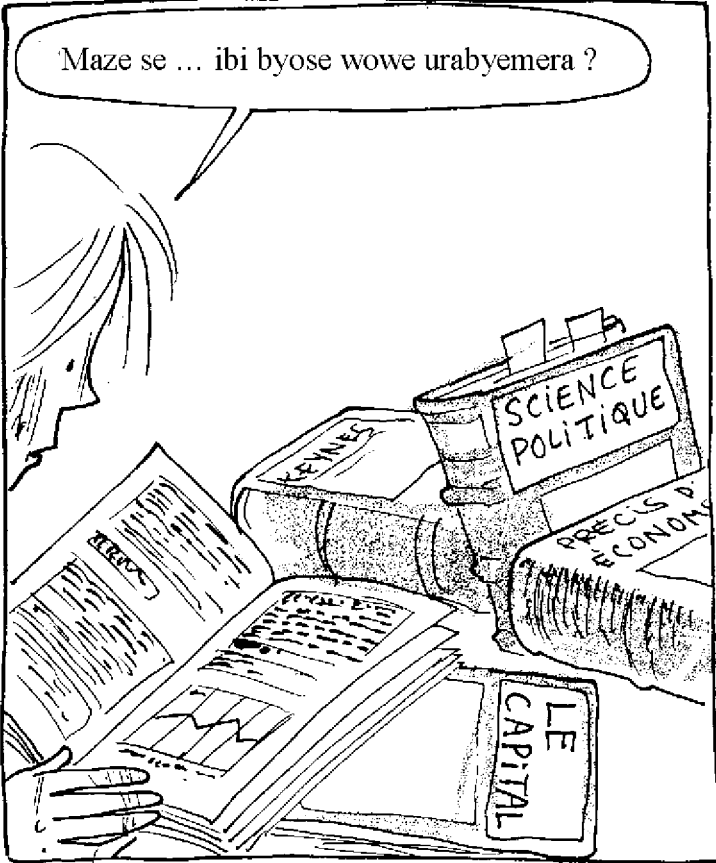

Maze se ... ibi byose wowe urabyemera ?



Urabize, ibyo alibyo byose, umuntu agomba kubona ikimutunga ...

Ukize cyangwa ukennye bitwaye iki mu gihe ufite amafaranga ...

HA! HA! HA!

Kuli ubu butindi bw'isi, ndabona ikintu kimwe gusa amafaranga atagura ...

Ntabwo ufinda icyo alicyo? ...

Eee... oya

e... yego

Sinje wahera ...

Reka tubapfe agasoni dupfuke iki gice k'inkuru ...

GUGU...GUGU



KLOK !

PA !

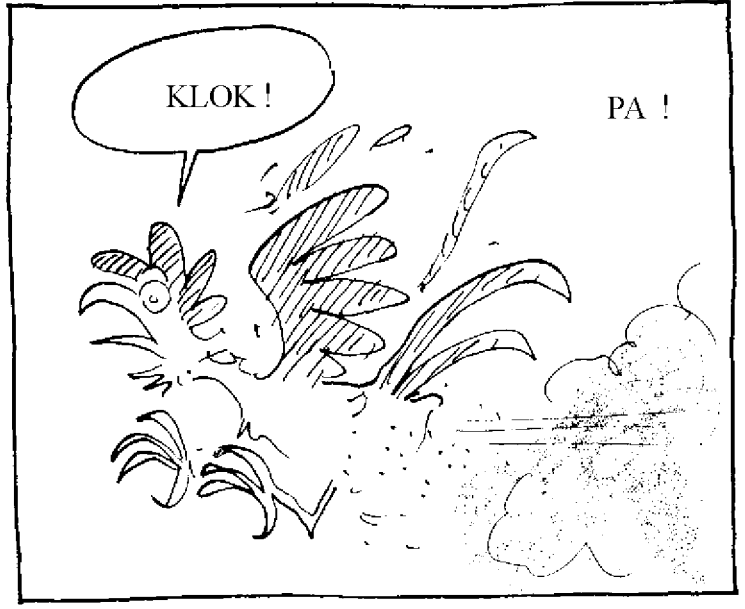

Hali abarwaye umutima cyangwa amaguru ...



Njyewe ni umutwe !

Reka ndebe. Yashyize he bisurufite ya palimezane ?



Anselme, njye ni icyayi gikaze ...

Aliho ibi byatsi ni nyabaki ?

Ni ibibabi bya FUTURODANDURO

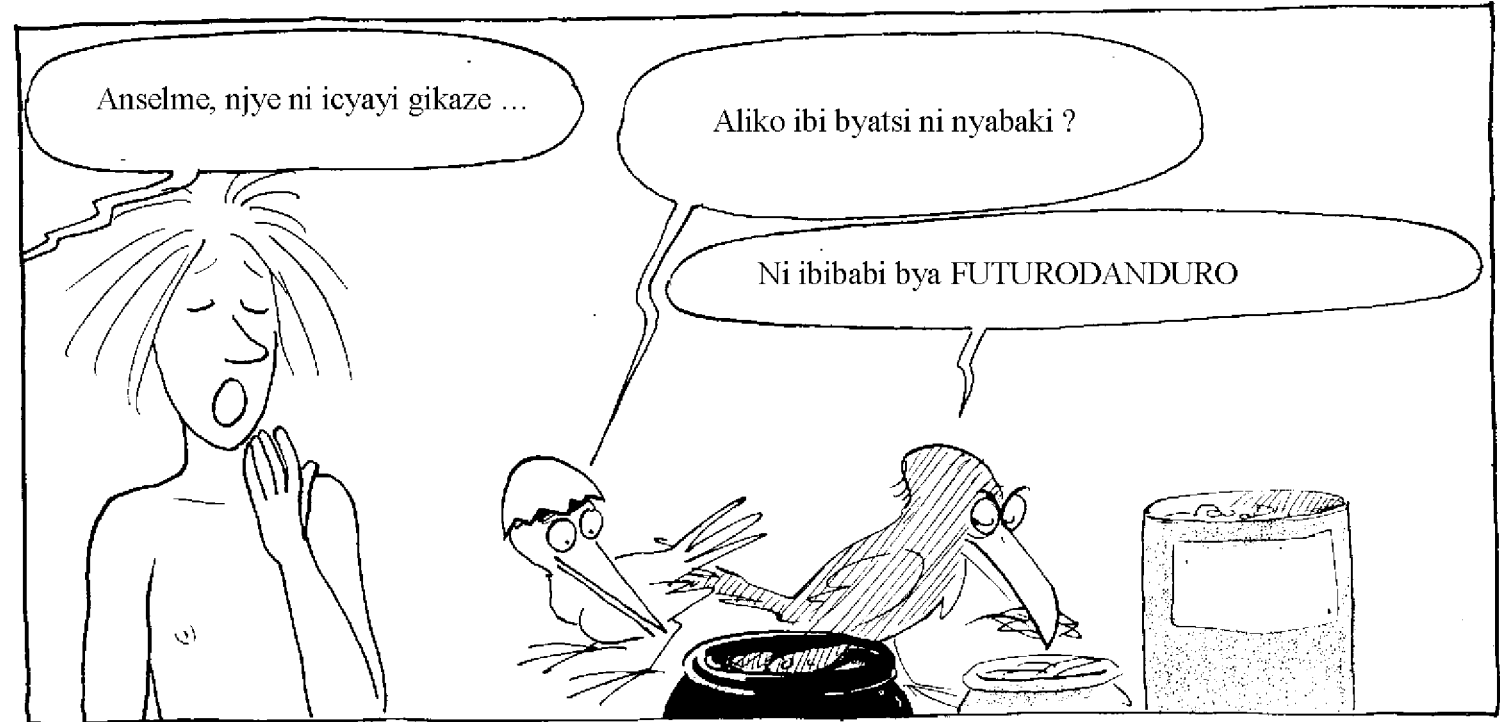



Aha, ka cyayi !

Umutobe w'ibibabi w'igiti cy'inzuzi
iyo uwunyuye utuma ujya mu
BIHE BIZAZA

Ni iki utazanyemeza !!!

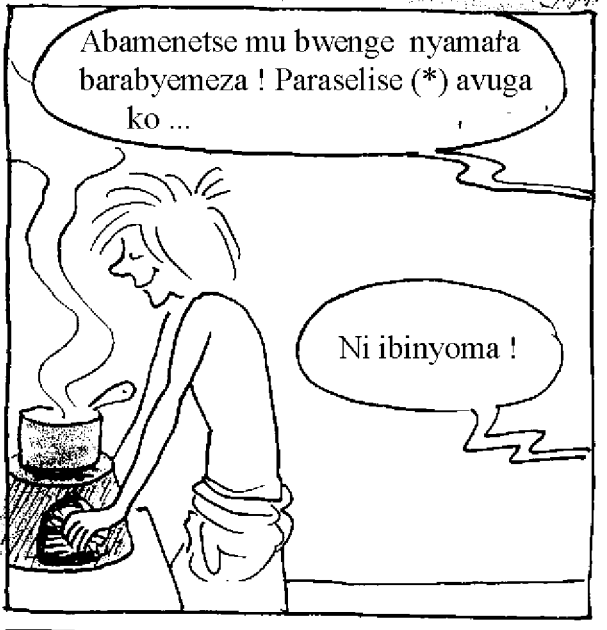

Abamenetse mu bwenge nyamafa
barabyemeza ! Paraselise (*) avuga
ko ...

Ni ibinyoma !



Bigenze bite ?

Paraselise avuga
ngo iki ?

(*) umwalishimisiti w'imena

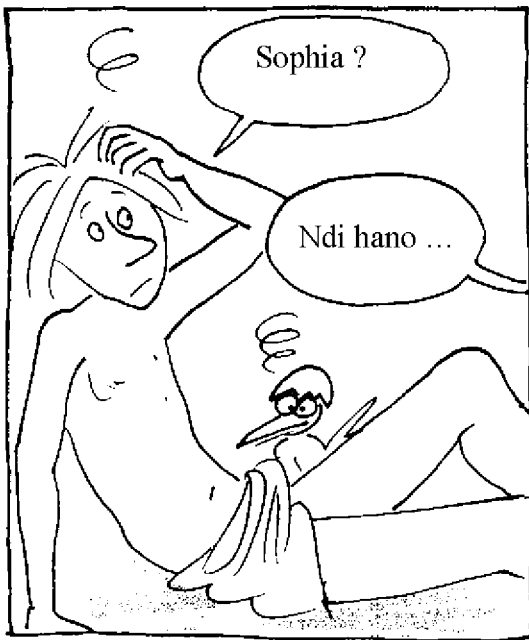

Sophia ?

Ndi hano ...

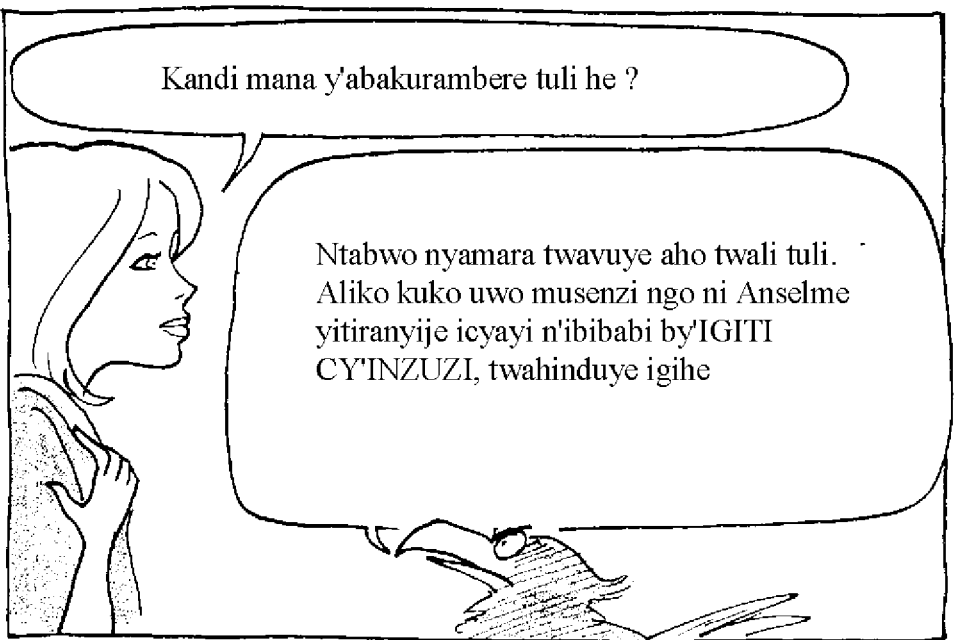

Kandi mana y'abakurambere tuli he ?

Ntabwo nyamara twavuye aho twali tuli.
Aliko kuko uwo musenzi ngo ni Anselme
yitiranyije icyayi n'ibibabi by'IGITI
CY'INZUZI, twahinduye igihe



Mwabonye izi mashini zose !

Bite ! Ni ubwambere ubonye IMASHINI
Y'UBUKUNGU.

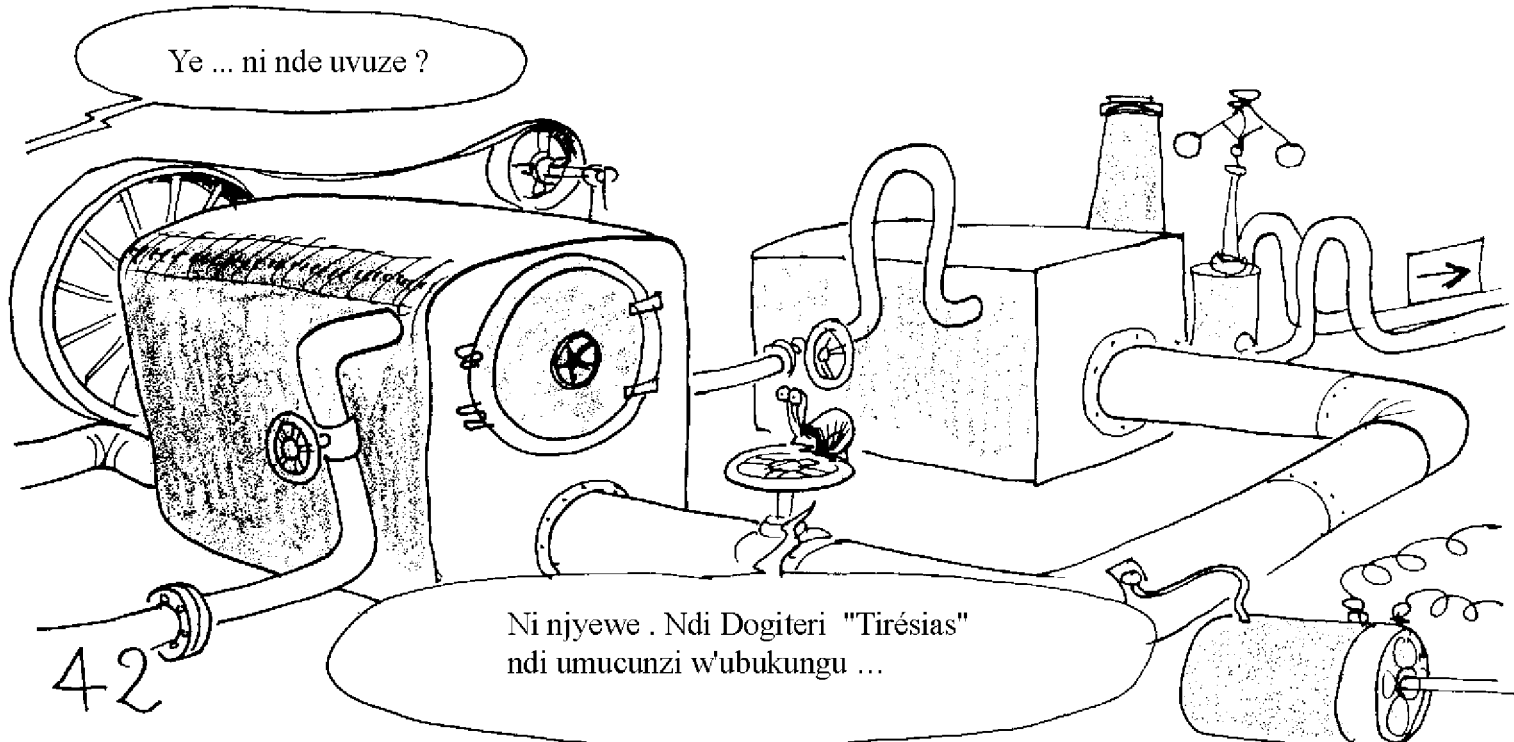

Ye ... ni nde uvuze ?

Ni njyewe . Ndi Dogiteri "Tirésias"
ndi umucunzi w'ubukungu ...

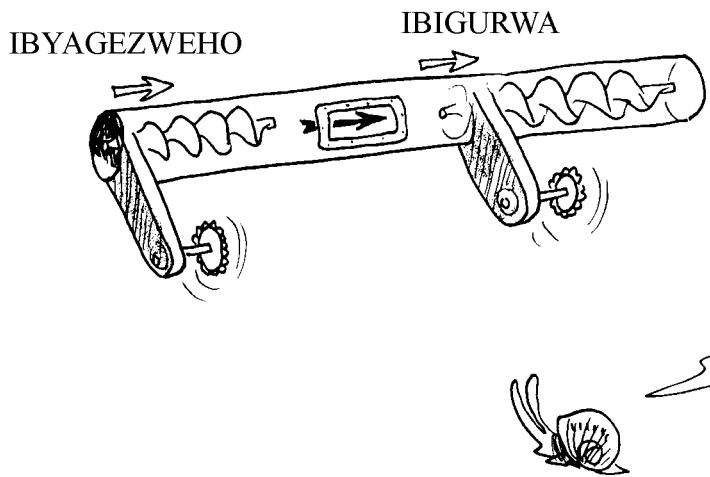
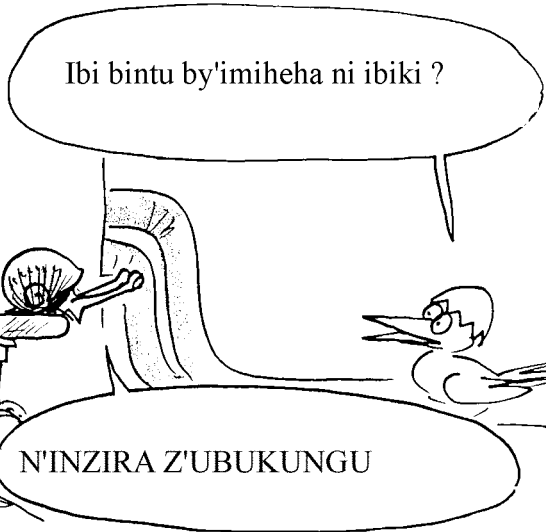
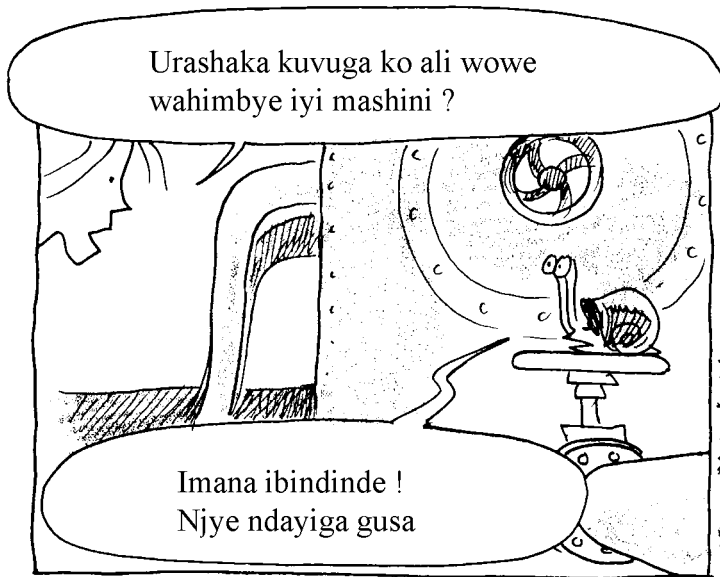

Mu matiyo, umugezi w'ubukungu, FULUZE, usunikwa n'amapompe y'amavisi y' "Archimède". Pompe iwusohora yitwa IBYAGEZWEHO naho pompe iwinjiza ikitwa IBIGURWA.



FULUZE ikozwe n'imvange ya "ERGOL" n'umwuka. "Ergol" itemba nk'amazi kandi NTIGABANURWA umubyimba. Aliko udupira tw'umuka tulimo dutuma umubyimba wa FULUZE ushobora KUGABANURWA.

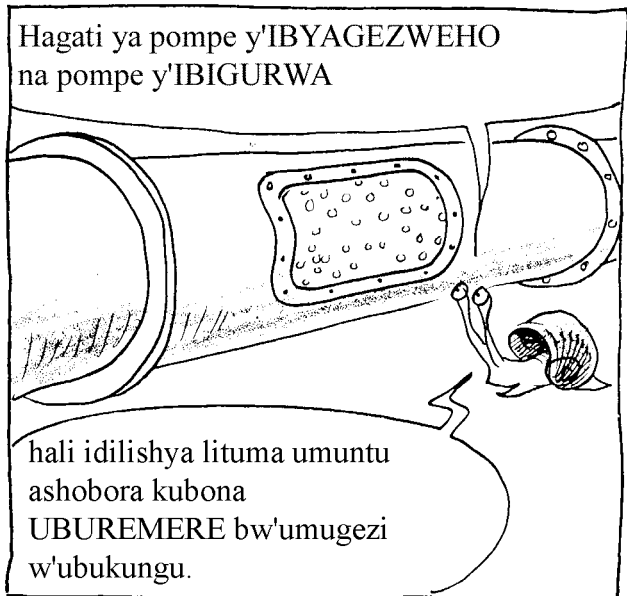

Hagati ya pompe y'IBYAGEZWEHO na pompe y'IBIGURWA

hali idilishya lituma umuntu ashobora kubona UBUREMERE bw'umugezi w'ubukungu.

(*) Izina liva kuli ERGOS mu kigereki : akazi

IBYAGEZWEHO

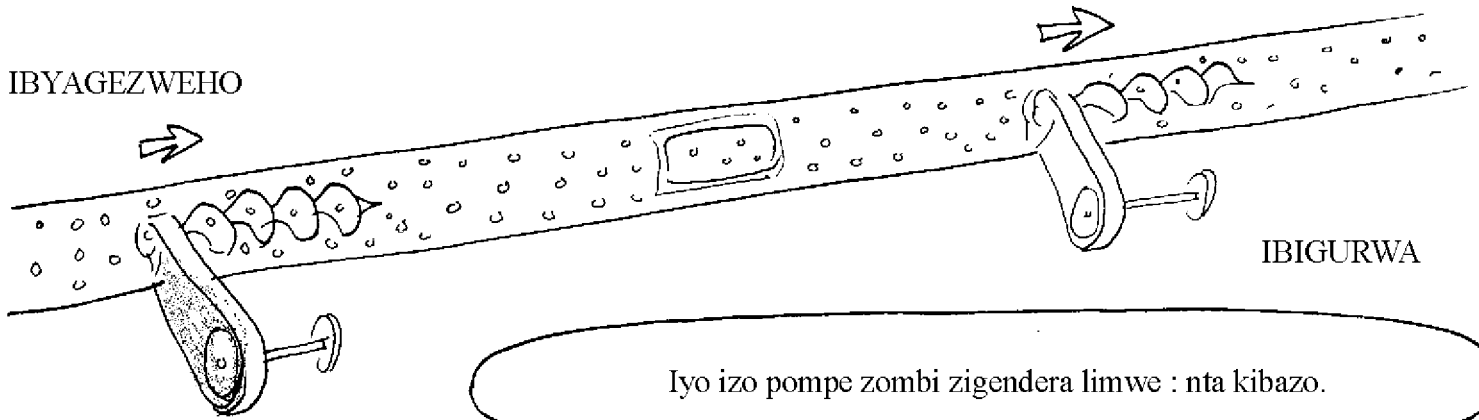

Iyo izo pompe zombi zigendera limwe : nta kibazo.

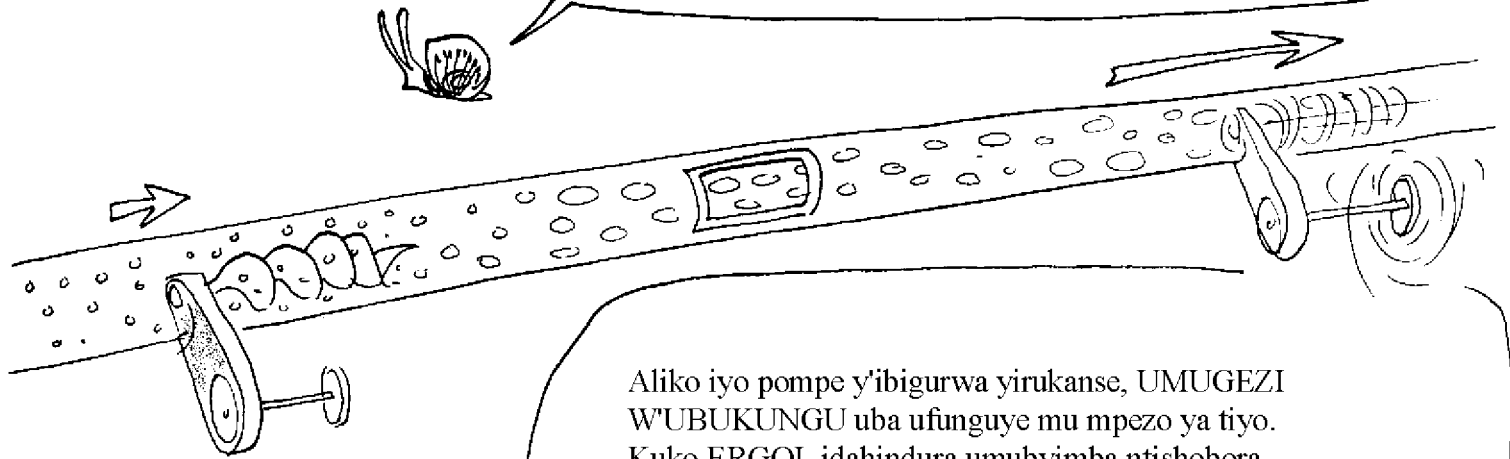

Aliko iyo pompe y'ibigurwa yirukanse, UMUGEZI W'UBUKUNGU uba ufunguye mu mpezo ya tiyo. Kuko ERGOL idahindura umubyimba ntishobora gufungurwa cyangwa gukomezwa, ni udupira tw'umwuka tubyimba noneho uburemere bwa fuluze BUKAGABANUKA.

Niko, Dogiteri "Tirésias" , igabanuka ly'uburemere bwa FULUZE lyibutsa ITA AGACIRO LY'IFARANGA lyatewe n'IZAMUKA LIKABIJE LY'IBICIRO.

Ni uko ni ibyo !

UMUVUDUKO ya pompe y' IBYAGEZWEHO ni IBIDANDAZWA ; naho ivudukaya pompe y' IBIGURWA ni IBIKENEWE.

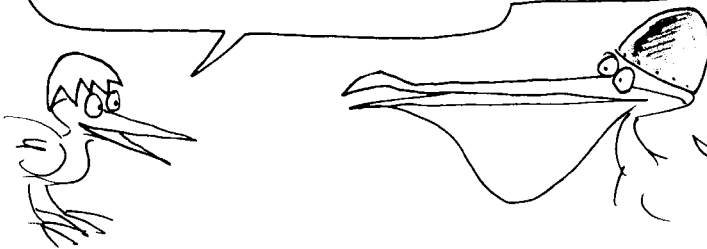

Iyo iyo mivuduko yombi ingana cyangwa zihinduka kimwe, mu NJYANA IMWE, FULUZE igumana uburemere bumwe : IBICIRO NTIHINDAGULIKE



Iyo pompe y' IBIGURWA itangiye gukurura cyane naho INJYANA Y'IBYAGEZWEHO ntikulikire, rero FULUZE iratubuka ; uburemere bwayo bukagabanuka noneho IBICIRO bikazamuka.

Buretse ...

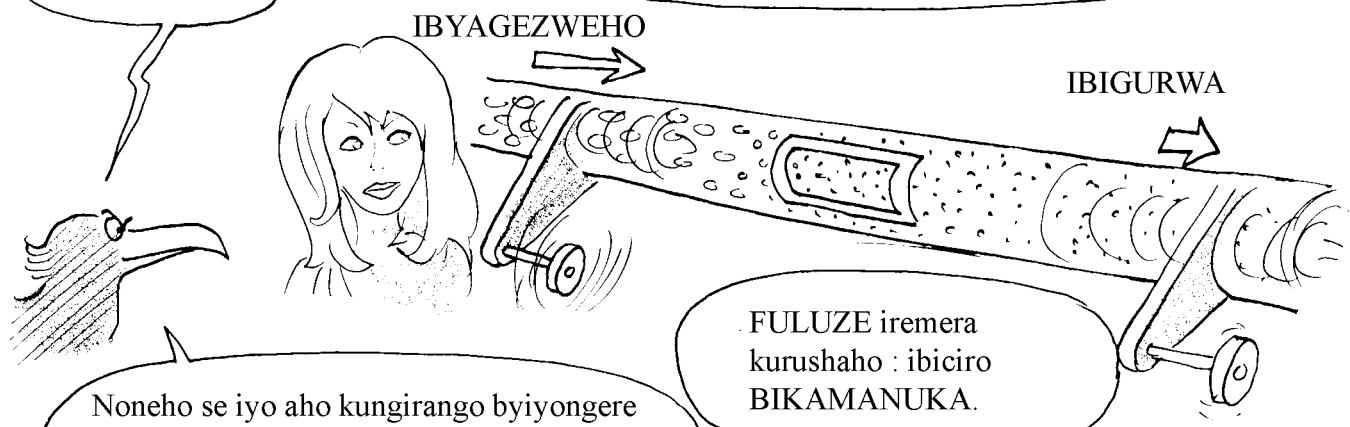

Noneho se iyo aho kungirango byiyongere iyo ibigurwa BIGABANUTSE ?

FULUZE iremera kurushaho : ibiciro BIKAMANUKA.



Ni kimwe niyo INJYANA Y'IBIGURWA idahinduka, IBYAGEZWEHO bikagenda buhoro : FULUZE iratubuka noneho ibiciro bikaguruka. Iyo IBYAGEZWEHO byihuse, IBYAGEZWEHO BIRENGEJE URUGERO bitsindagira FULUZE noneho ibiciro BIKAMANUKA.

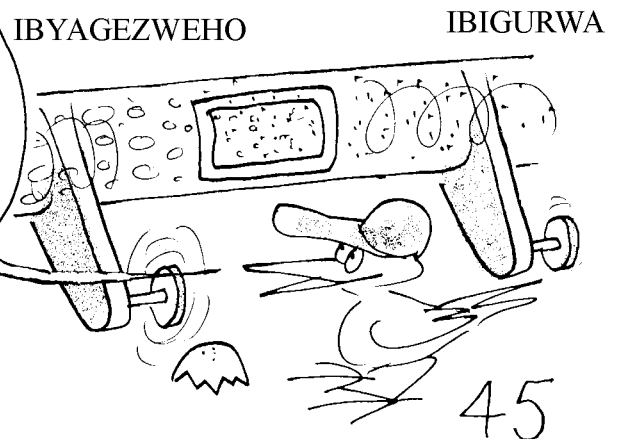

Niyo mpamvu, ibiciro bulya BYISHYIRAHO bigereranyije IBIGURWA n'IBYAGEZWEHO, hamwe n'IBIKENEWE n'IBIDANDAZWA.

Muli pompe y' IBYAGEZWEHO hali IBIRO bicamo bya ERGOL mw'isogonda. Iyo ruhurura y'IBIRO ni imwe nkihita muli pompe y'IBIGURWA

Igereranyo ly'umuvuduko mu mbyimba no mu biro bya ERGOL muli pompe y'IBIGURWA, yitwa IGENGA LY'IBICIRO

Reka twitegereze iyi MASHINI Y'UBUKUNGU neza

Wagirango ni imashini ikora ubudahagarara

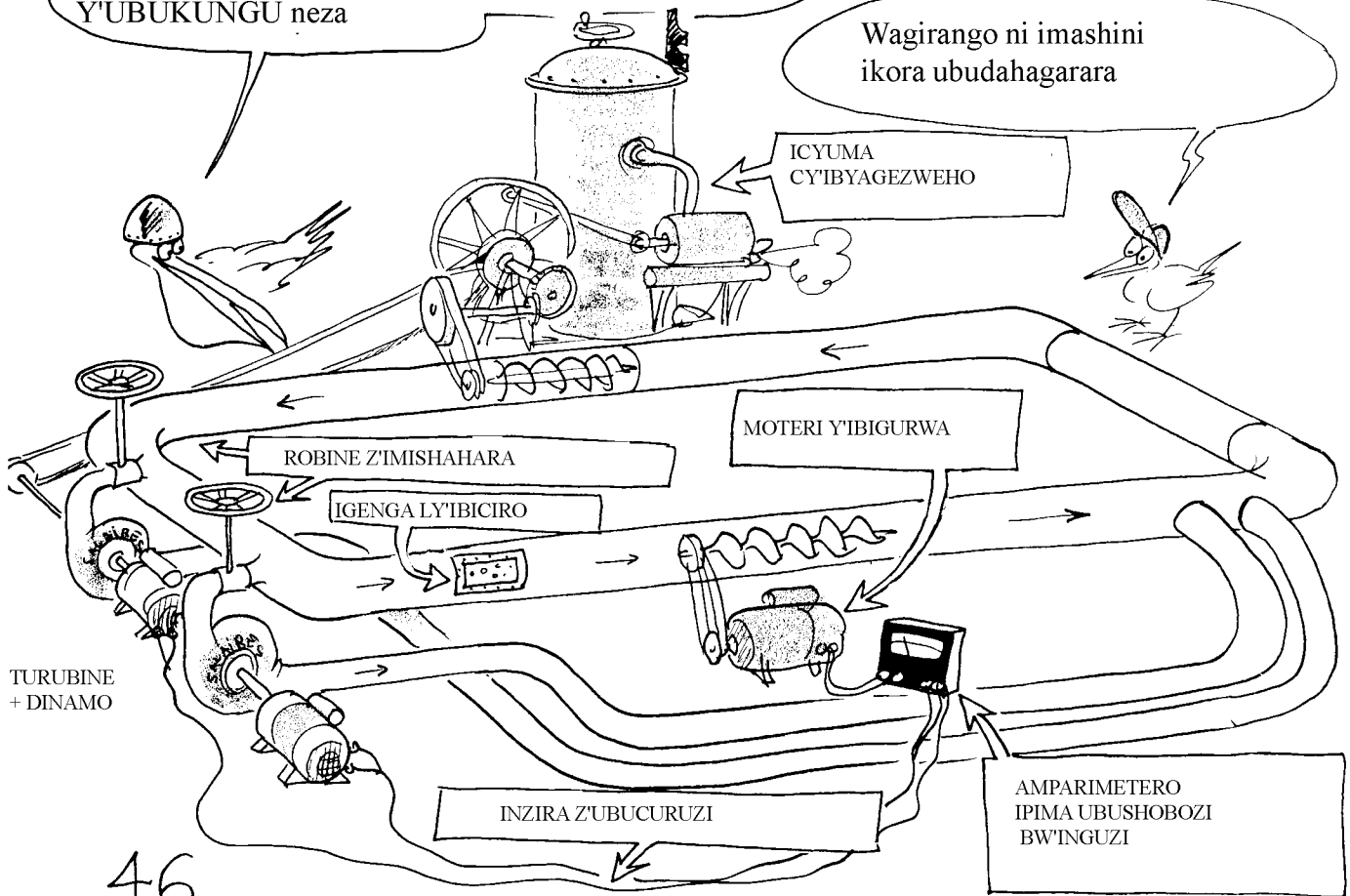



Oya da, ntabwo ali imashini ikora ubudahagarara

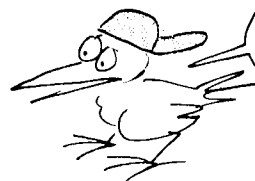

Njye, icyo nabivugagaho ...

FULUZE yitsilira ku nkombe, n'imbere musinga nti hanyerere, bikagabanura umuvuduko. Kugirango byose bigende neza bigomba guhabwa INGUFU.

ITEGEKO LYA KABILI LY'UBUTEMBERE BWA FULUZE

Itegeko lya kabili ly'ubutembere bwa FULUZE lishobora kuvugika gutya : NTA MASHINI Y'UBUKUNGU ISHOBOA KUBAHO YONYINE

Ntabwo abantu bashobora kugura cyangwa kugulisha gusa, ku jana mu masoko ibintu. Hagomba kubaho ahantu BIKORERWA bakoresheje ingufu, bagahera ku bintu bya mbere na mbere, mbere yuko bagira ibindi babihinduramo cyangwa bihita bijya mu masoko.

Birumvikana

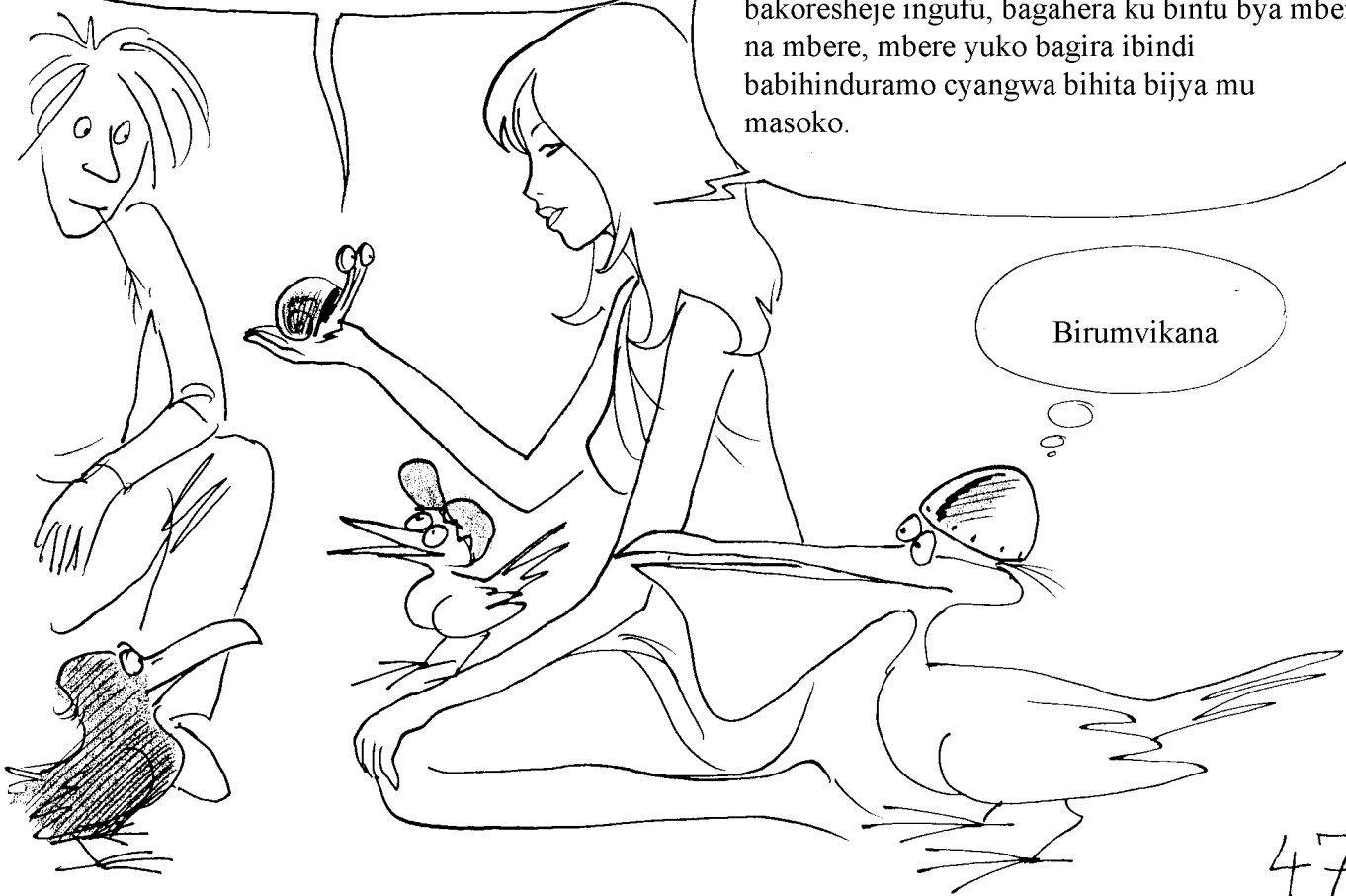

SEGITERI IGERA
§ ITAGERA KU BINTU

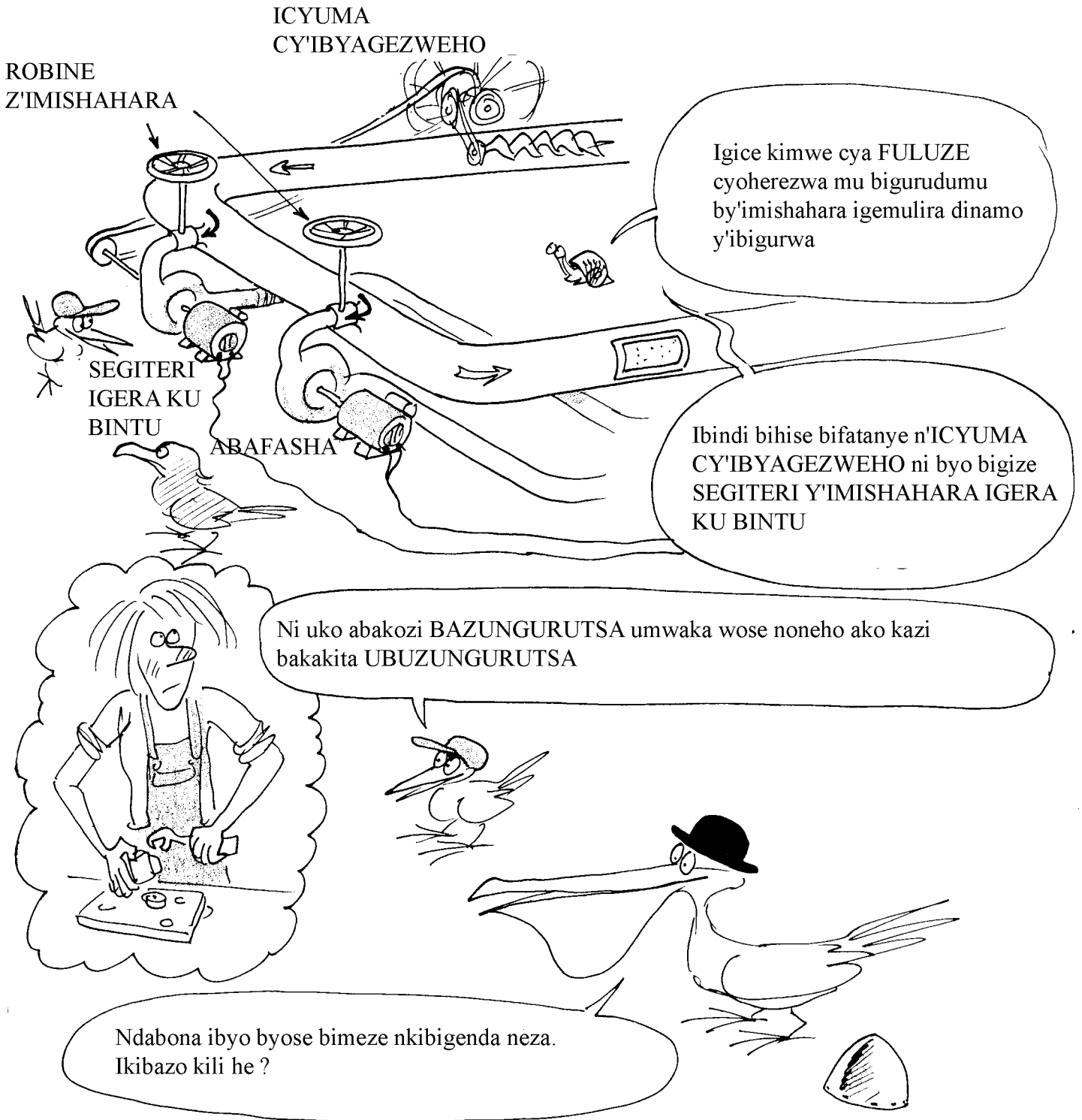

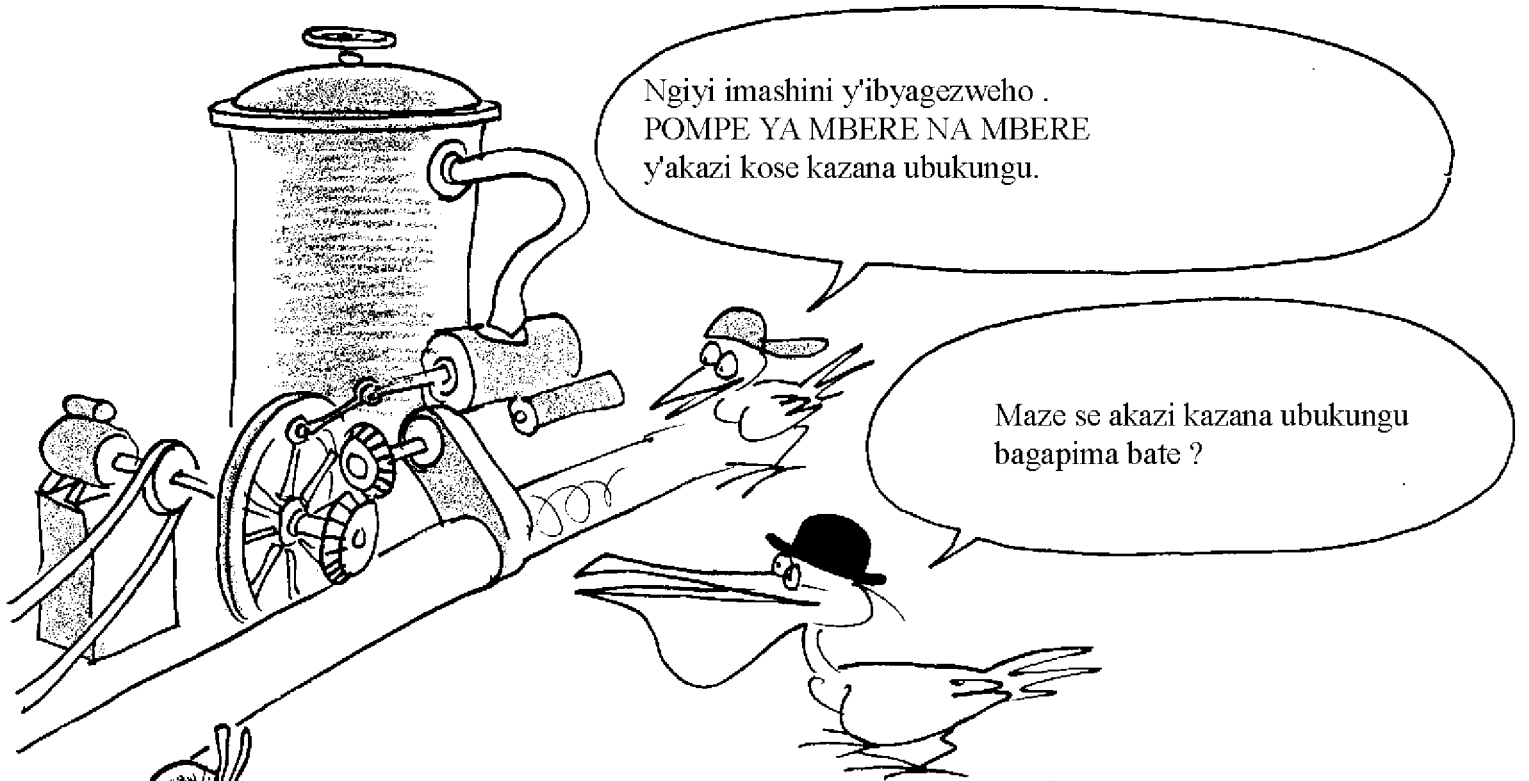

Ngiyi imashini y'ibyagezweho .
POMPE YA MBERE NA MBERE
y'akazi kose kazana ubukungu.

Maze se akazi kazana ubukungu
bagapima bate ?

Reba, AKAZI KAZANA UBUKUNGU kangana na :
 $\frac{1}{2}$ IBIRO BYA ERGOL X (UMUVUDUKO W'UKO ITEMBERA)2



Mu magambo make ni zo MBARAGA
ZISHOBORA GUKORESHWA

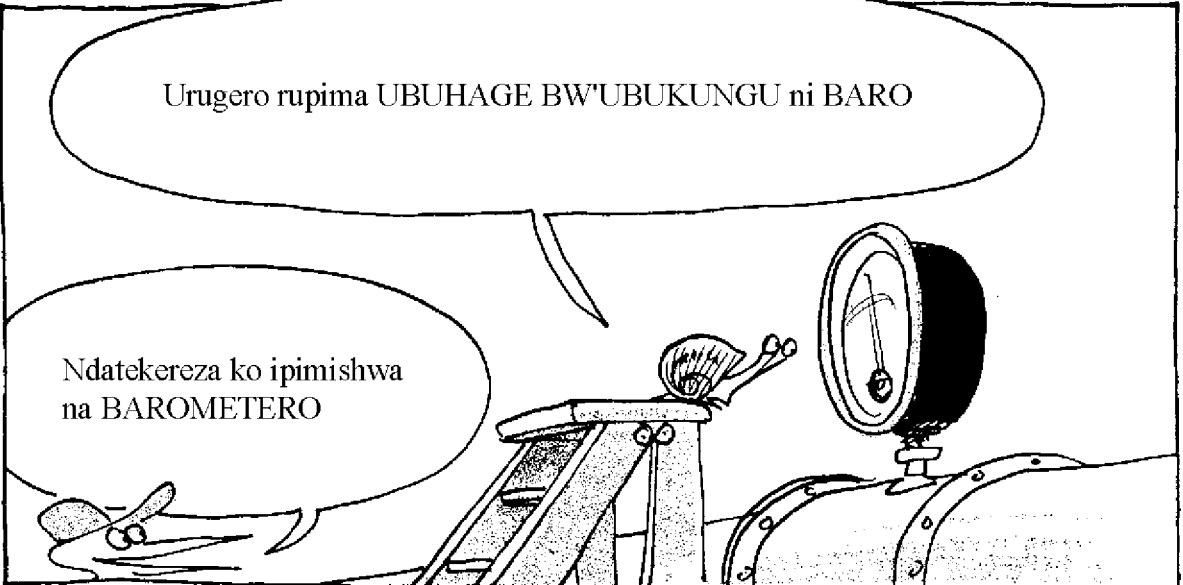

Urugero rupima UBUHAGE BW'UBUKUNGU ni BARO

Ndatekereza ko ipimishwa
na BAROMETERO

Kugirango bagure akazi kazana ubukungu, bashobora kongera **IBIRO BYA ERGOL**, alibyo bivuga **UMUBARE W'AKAZI KAKOZWE**. Alike ni ngombwa kurushaho kwiga neza ukuntu ako kazi gakoreshejwe, gatanzwe, alibyo bivuga **UBUKORWA BW'IBINTU**.

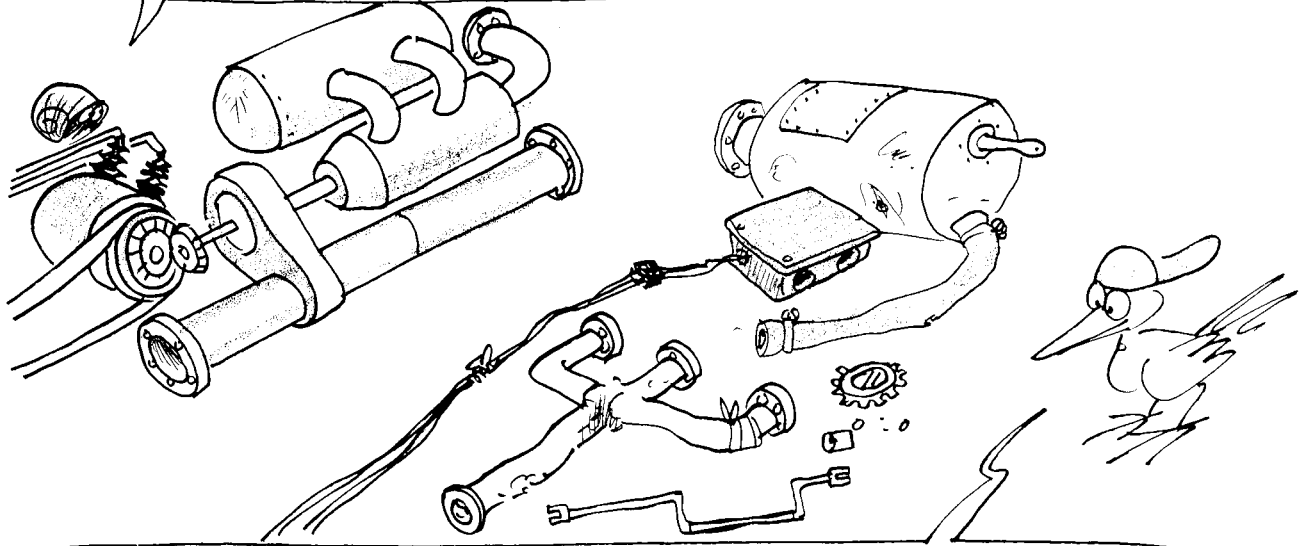

Yee, gushaka imashini irushijeho kuba nini ni byo byiza, imashini y'ubu, ifite amatiyo manini n'insinga z'umuliro nini, aho kongera inshuro ebyili cyangwa eshatu ibyuma by'imashini ya cyera.

Hali ikintu gikomeza kunyobera :
ni nde utegeka umubyimba wa **FULUZE**
bashyira mu mashini y'ubukungu ?

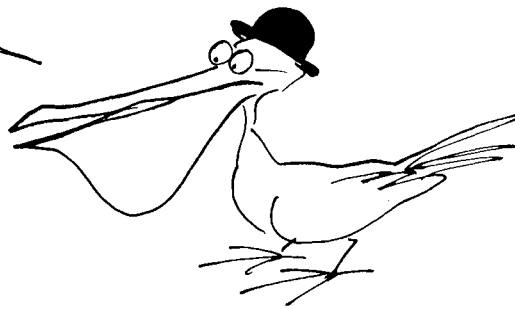

ITERA IMBERE LY'UBUKUNGU N'AMAFRANGA Y'IGIHUGU

Icyerekana ICUNGA BUKUNGU NYAYO bw'ahantu ni IBIRO BYA ERGOL bihatembera. Ni igice kiremereye cya FULUZE, IMBARAGA Z'AKAZI, wongeyeho UMUVUDUKO wa ERGOL. Bigenda bite iyo ucometseho ikindi CYUMBA CY'IBYAGEZWEHO ku mashini ?

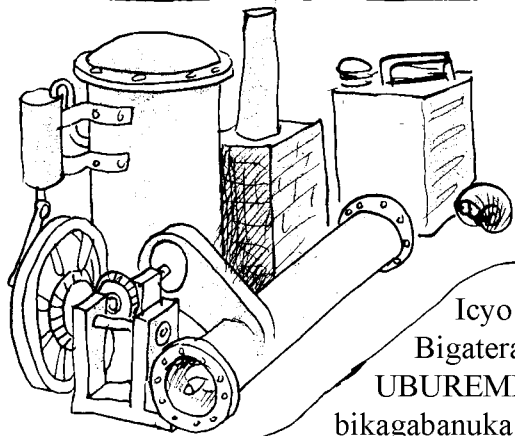

Icyo cyuma cy'ibyagezweho kigulishwa na ERGOL yacyo. Bigatera ily 'iyongere ly 'IMBARAGA Z'AKAZI, nazo zigatuma UBUREMERE BWA FULUZE bushaka rero kwiyongera (ibiciro bikagabanuka. Birumvikana ko muli icyo gihe cy 'itera imbere y 'ubukungu, bongeramo udupira tw'umwuka bivuga kongera UMUBYIMBA W'AMAFRANGA Y'IGIHUGU ku bulyo IBICIRO BIDAHAINDAGULIKA.

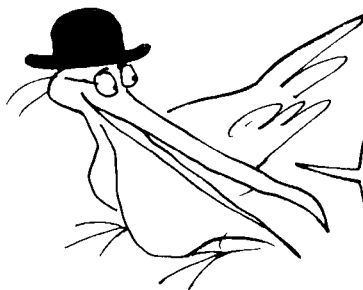

Bityo, ntawe ubibona, mukongeraho buli gihe, arushijeho buhoro, buhoro bikaramira umyiyongere y'imishahara.



Tekereza ko tuli mu gihe cy'itera imbere ly'ubukungu. Max, urakina umukozi wo muli segiteri igerera ku bintu, naho wowe, Albert, umukozi wo muli segiteri itagera ku bintu.

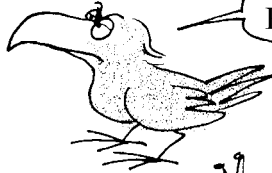

Kubera iki itagera ku bintu ? ...

Urakina ABAFASHA, abo MU BIRO

Ku mashini y'ubukungu hacometsweho ikindi CYUMBA CY'IBYAGEZWEHO. Byose biragenda neza. Ku gipimo cy'ubuhage bw'ubukungu handitseho baro cumi n'ebiyili zirenga.

Kongeraho ikindi cyumba cy'ibyagezweho bizatanga AKAZI bigabanure SHOMAJE. Aliko ikibazo cy'imishahara kizakara.

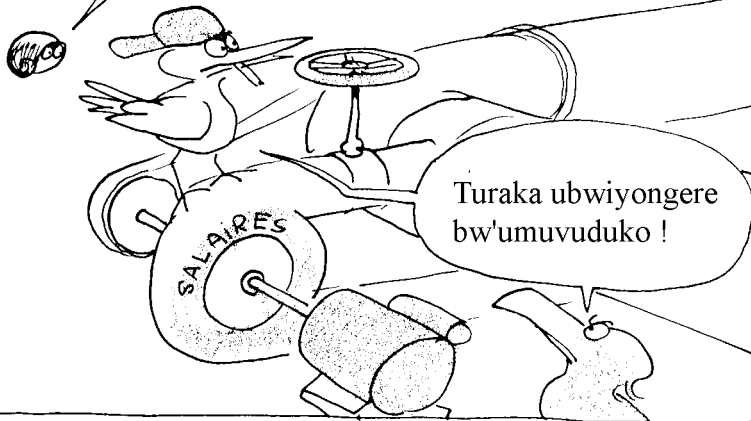
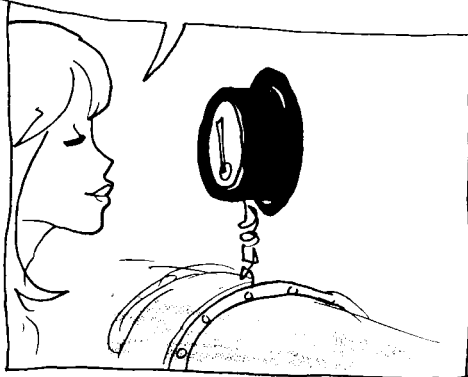

Turaka ubwiyongere bw'umuvuduko !

Sawa, nkoherereje ubwiyongere bw'umuvuduko

IBICIRO ... ni byo ... buhoro ...

Uburemere buliyongera. Ntabwo tulimo gutakaza cyane mu NZIRA Z'AMASOKO.

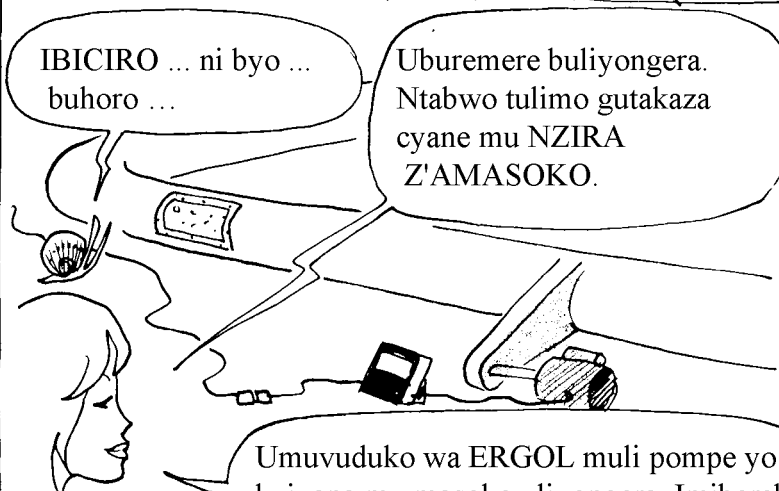

Umuvuduko wa ERGOL muli pompe yo kujyana mu masoko uliyongera. Imibereho iratera imbere.

Icyo cyumba gishya ntabwo cyikoze ?

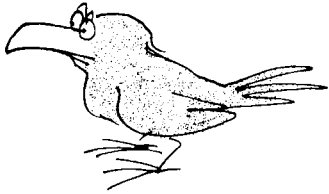

Uvuze ukuli. Bagomba gufata igice cy'imbaraga zishobora gukoreshwa za FULUZE kugirango BAKORE IBINTU BISHYA BANAVUGURURE icyuma cy'IBYAGEZWEHO.



ISHORA LY'AMAFRANGA

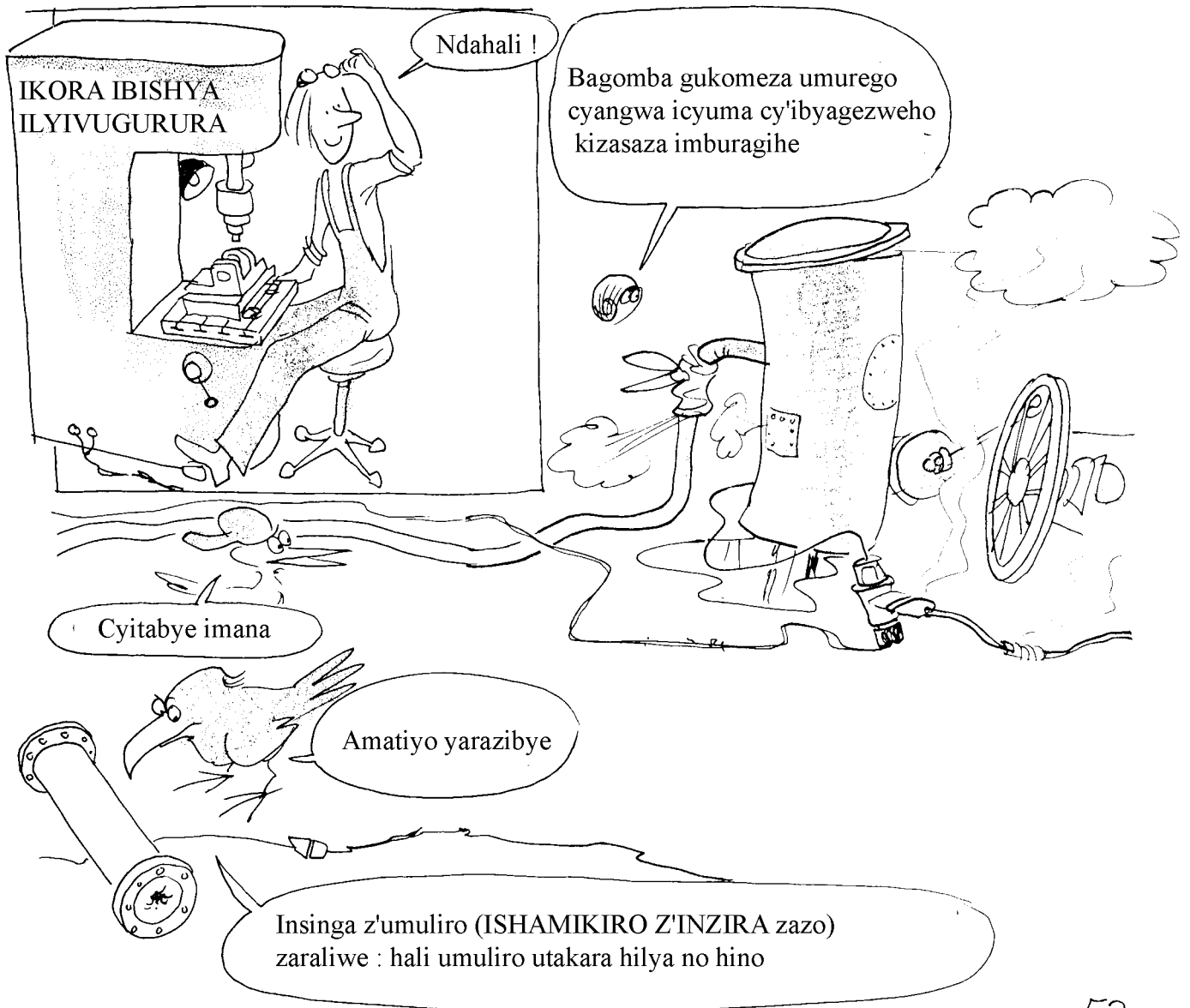

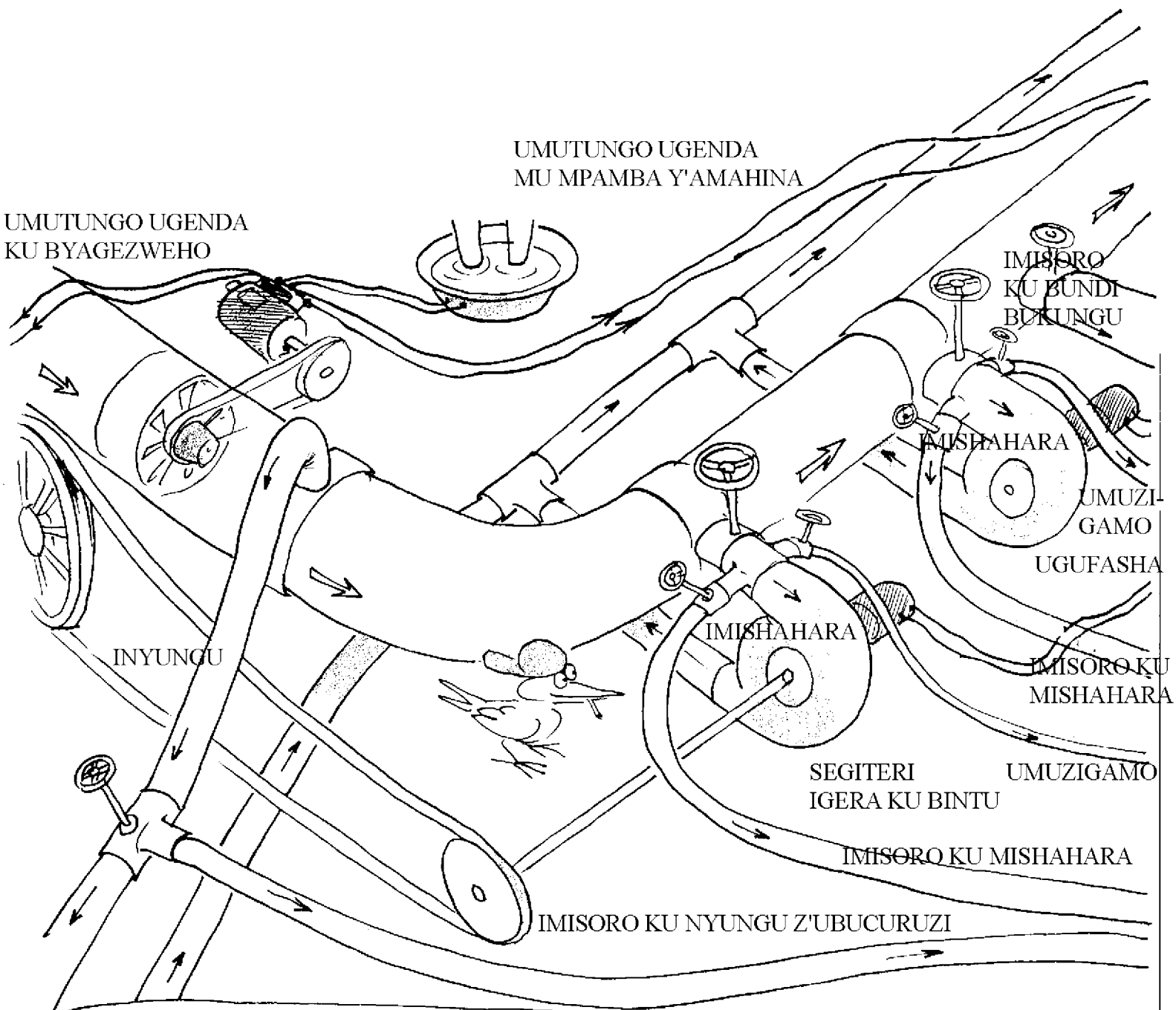

Itembera Iya FULUZE libogamiwe n'amayoba nzira menshi n'ibihombo bitewe n'ibigombwa kulihwa hilya no hino. Mu mpera ya pompe y'ibyagezweho, idatindijemo, ERGOL ikoresha ikigurudumu gifatanye n'icyuma gitanga ingufu. Igice kimwe cy'izo ngufu cyoherezwa mu nzira z'imfashanyo zitwa IMPAMBA Y'AMAHIRA. Ikindi gice kikajya kwishyura UMUTUNGO UGENDA MU BYAGEZWEHO naho ingufu zisigaye zikayoborwa mu gushyushya amazi yo koza ibirenge bya bwana FULUZEMAKER.

Dore hano bwana
FULUZEMAKER

Hilya inzira z' IMPAMBA
Y'AMAHIRA

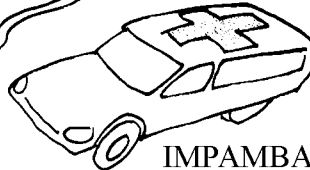
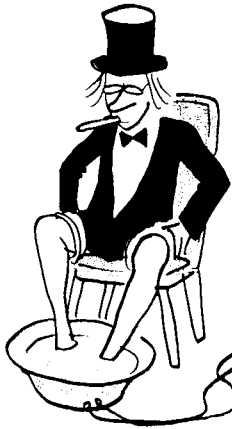

IMPAMBA
Y'AMAHIRA

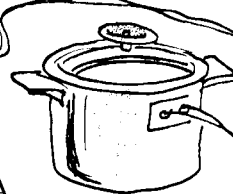

IKIRUHUKO
CY'IZABUKURU

IMPAMBA
Y'IMILYANGO

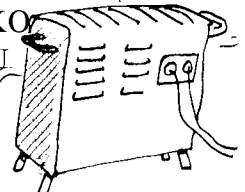

SHOMAJE

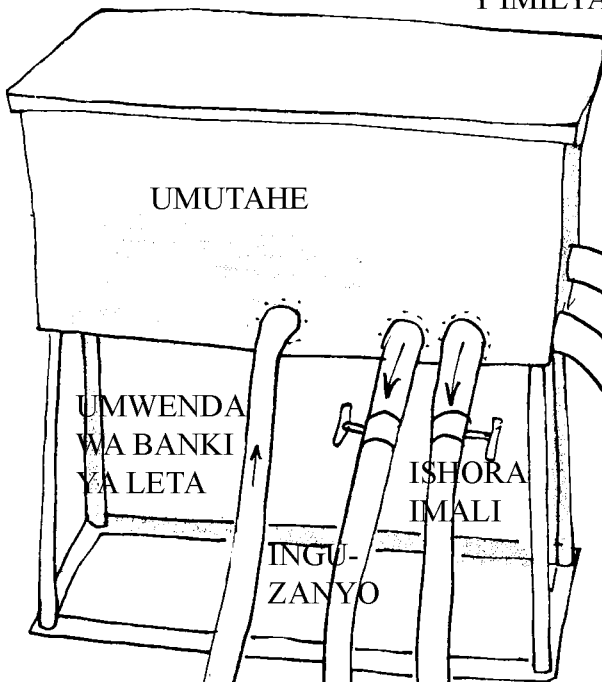

UMUTAHE

UMWENDA
WA BANKI
YA LETA

ISHORA
IMALI

INGU-
ZANYO

Mu icupa lyo kwagura, FULUZEMAKER ahunikamo FULUZE, iyo ahinduye ingufu z'imbaraga zituma ERGOL itemba mu ngufu z'imbaraga isanganywe : ITANGIZO

INYUNGU UKUYEMO
IMISORO

UMUZIGAMO

MU NZIRA
ZIBISHYA
N'IBIZAVUGURURWA

Ingunguru y'UMUTAHE igemulirwa n'INYUNGU ISIGARA UKUYEMO IMISORO, hamwe n'ikindi kintu bita UMUZIGAMO.

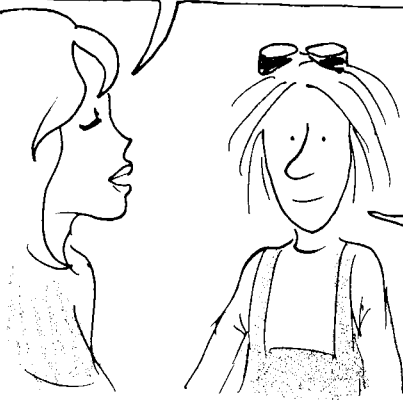

Naho FULUZE y'ilyo cupa ly'ukwagura ishobora koherezwa mu bigrudumu bifatanye n'ibyuma bitanga ingufu. Imwe igemulira imashini yanjye imwe y'ibishya n'ibivugururwa. Indi ikitwa INGUZANYO Z'UBUCURUZI.

Ku rundi ruhande, IMPANUKA Y'IMALI ifite umubiko wenda gusa utyo. Iwugemulisha IMISORO. Irabanza igafata UMUSORO KU NYUNGU Z'UBUCURUZI. Hanyuma UMUSORO KU MUTUNGO. Nyuma mu itangiliro ya POMPE Y'IBIGURWA ikahakura UMUSORO WO KU BUNDI BUKUNGU nahuha urugero rw'ISHA (umusoro baca kunyongerwa bukungu).

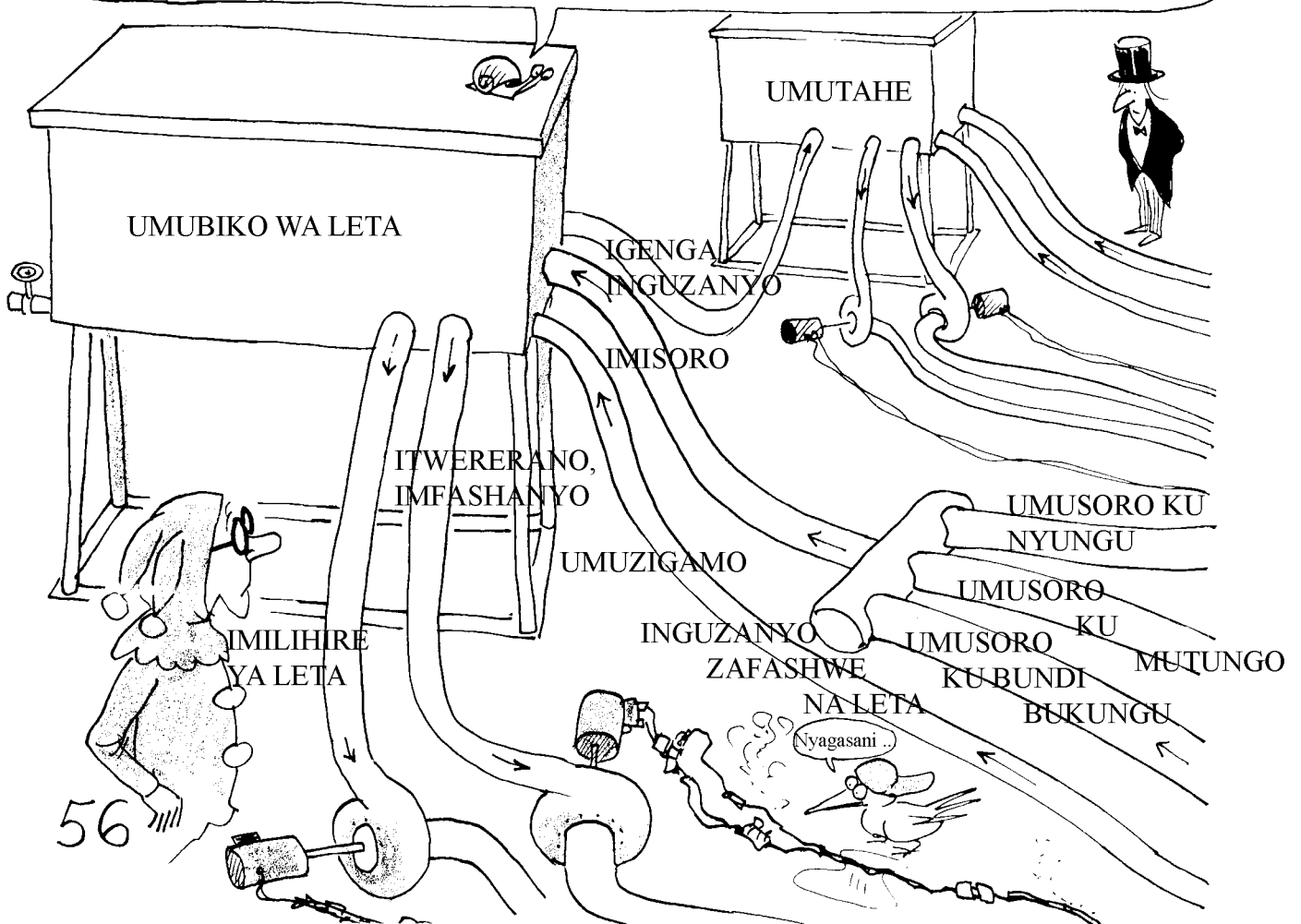

Aha, reba IMILIHE YA LETA

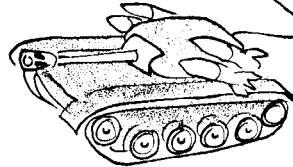

INGABO

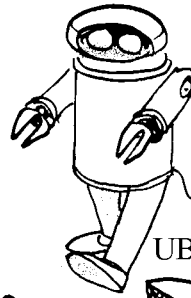

UBURERE - UBUSHAKASHATSI

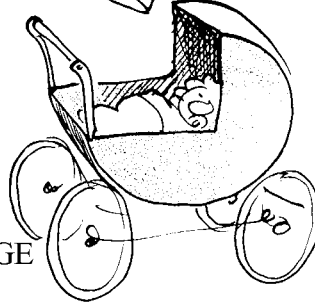

IMIBEREHO
Y'ABATURAGE

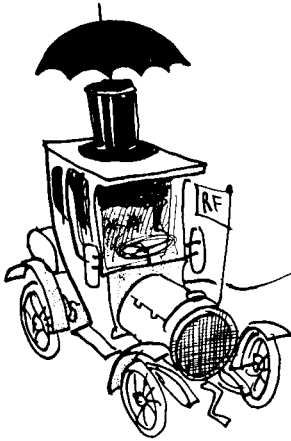

Iyi, ndakekako ali
GALIYAMOSHI YA LETA

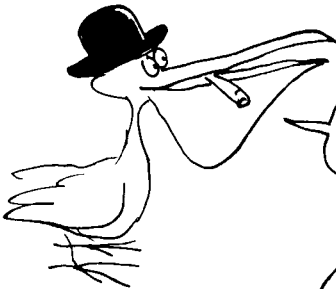

Naho UMUZIGAMO, INGUZANYO,
byo bigenda bite ?



Ayo macupa yose y'ukwagura agize UMUTAHE n'UMUBIKO WA LETA
afite IBIYAGENGA. Twabonye ko IMASHINI Y'UBUKUNGU ihora
IHUNGABANA, kubera isopana ya buli gihe y'IBYAGEZWEHO
n'IBIGURWA, ibigurwa bikaba bihora bishaka gusara bikazamura IBICIRO.



Noneho babwiliza abakozi gushyira FULUZE ya bo muli
ayo macupa abili y'ukwagura...

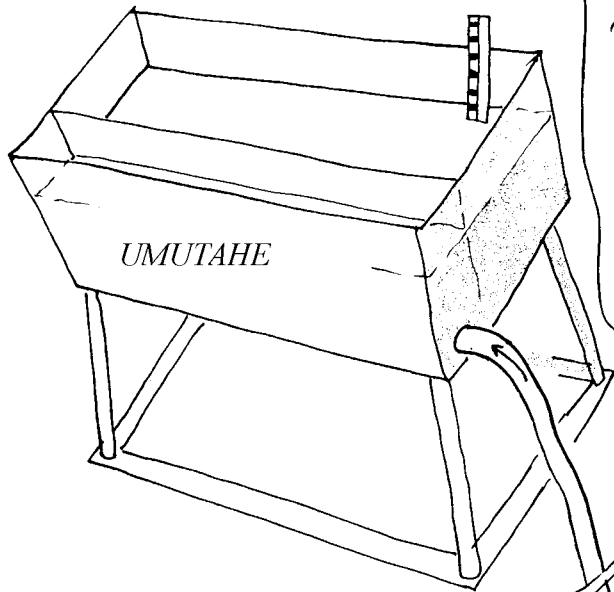

Nta mpamvu yuko mutagira uruhare muli uko gutera imbere k'ubukungu bwacu, bushimishije. Mu muvure wanjye wa FULUZE ndabagabiramo icyumba kidasanzwe (*) mushobora gushyiramo iyanyu. Ubungane bwayo buzakulikira ubwiyongere bw'umubyimba w'UMUTAHE.



Ntacyo muzatakaza. Mbijeje igihembo ku mwaka. Nimukoreshe FULUZE yanyu

Kubera icyo bika, tuzashobora gushora imali no kuvugurura imashini y'ubukungu yacu

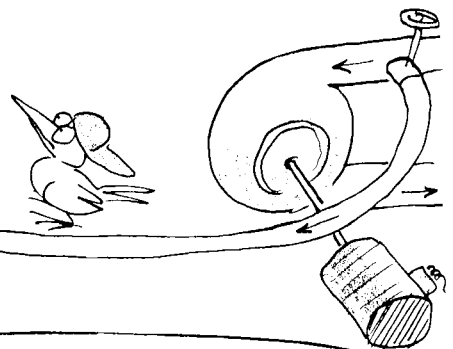

Nimushyingure FULUZE yanyu ahantu mwizeye. Nimwiteganyilize IMINSI ILI IMBERE. Mbijeje igihembo ku mwaka. Ni mumbikisha ubukungu bwanyu igihe kirekire bihagije, nzagira icyo mborohereza ku misoro.

Kubera icyo bika, tuzashobora gushora imali no kuvugurura imashini y'ubukungu yacu



Hum...

(*) Banki ya rubanda, ibikorwa.

HASHIZE IMINSI MIKE ...

Atujugunyira ubusa. Aliko, urabona ko tugize icyo twungutse mu mubyimba.

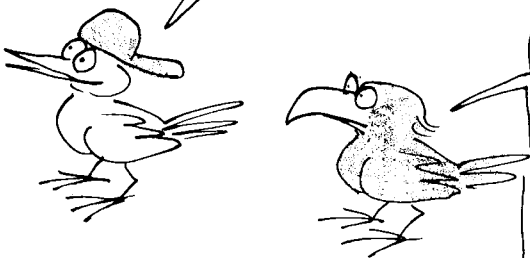

Uli umwana koko. Ibikorwa bizana ubukungu bilyongera. Kongeraho ibindi byumba bishya by'ibyagezweho bijyana n'itubuka ly'ibiro bya ERGOL. Aliko bashyiramo udupira tw'umwuka twinshi kubulyo UBUREMERE bwa FULUZE bukomeza kugabanuka. Amaherezo urahomba.

Urashaka kuvuga ko mu byo twazigamye, ubungane bwa ERGOL, igice kiremereye cy'umuvange, KIGABANUKA aho kugirango cyiyongere ?!...



Urakeka iki ? ...

Aliko imishahara yacu yaliyongereye. Imivuduko yikubye kabili ! Reba ...

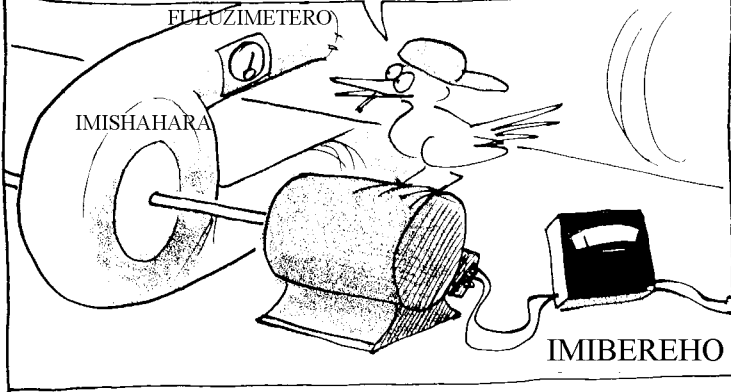

Erega ibyo uzungurutse ni IMPUHA, FULUZE igenda ifunguye kurushaho. Reba UBUREMERE !

POMPE Y'IBIGURWA



Bwo, bwazamutse buhora cyane

GUTERA IMBERE K'UBUKUNGU nyako ntabwo ali ukwiyongera umubyimba kwa FULUZE izunguruka, ni ubwa ERGOL ilimo. Nkuko izamuka y'IMIBEREHO atali UMUVUDUKO (umushahara) ali UBUREMERE (UBUSHOBOZI BWO KUGURA)



Nta kundi umuntu yakibikira FULUZE ye ?

Kugirango igumane IBIRO
BIDAHINDAGULIKA, ugomba
KUYIKONJESHAMO URUBURA

Icyo ni igitekerezo ! Kugirango twilinde
IZAMUKA LIKABIJE LY'IBICIRO,
iyo ndwara yamaze ubukungu, tugomba
twese kuyikonjeshamo urubura.

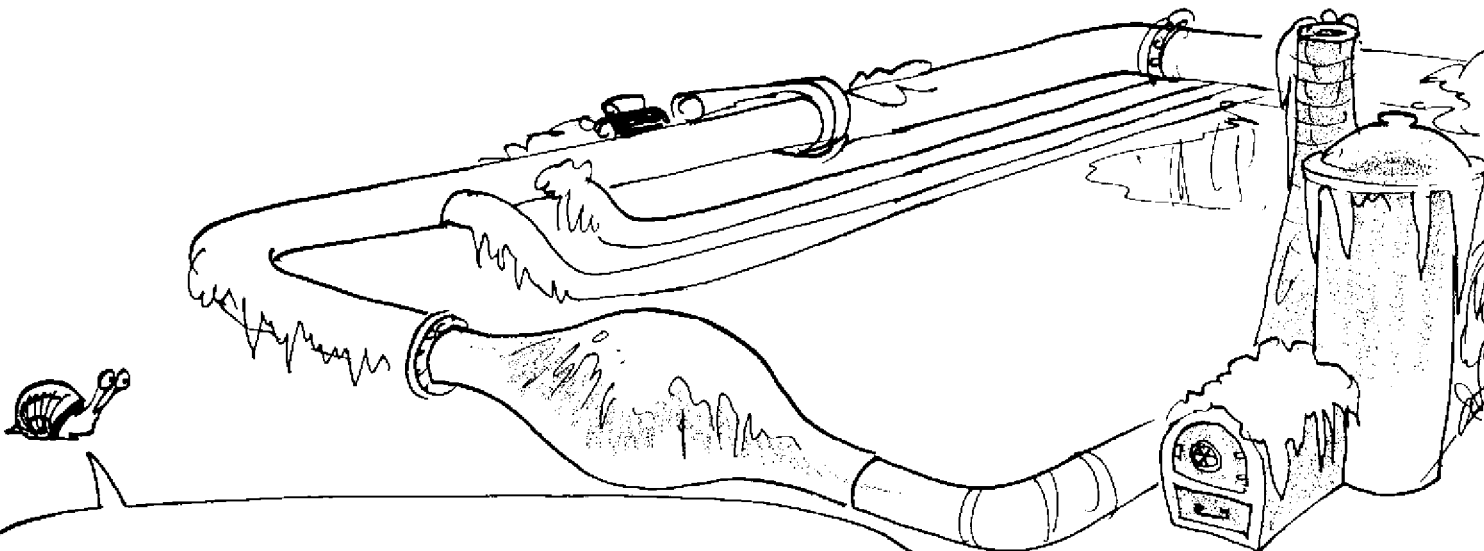
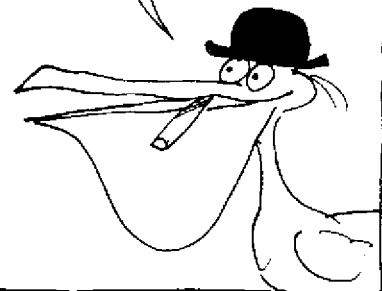
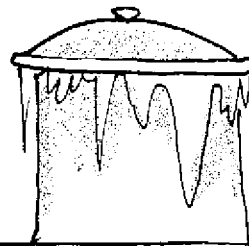

Maze se FULUZE nt'ita icyo bayikundiraga, cyali itemba lyayo.
GUHINDURA IMITAHE URUBURA, bihagalika imashini y'ubukungu.

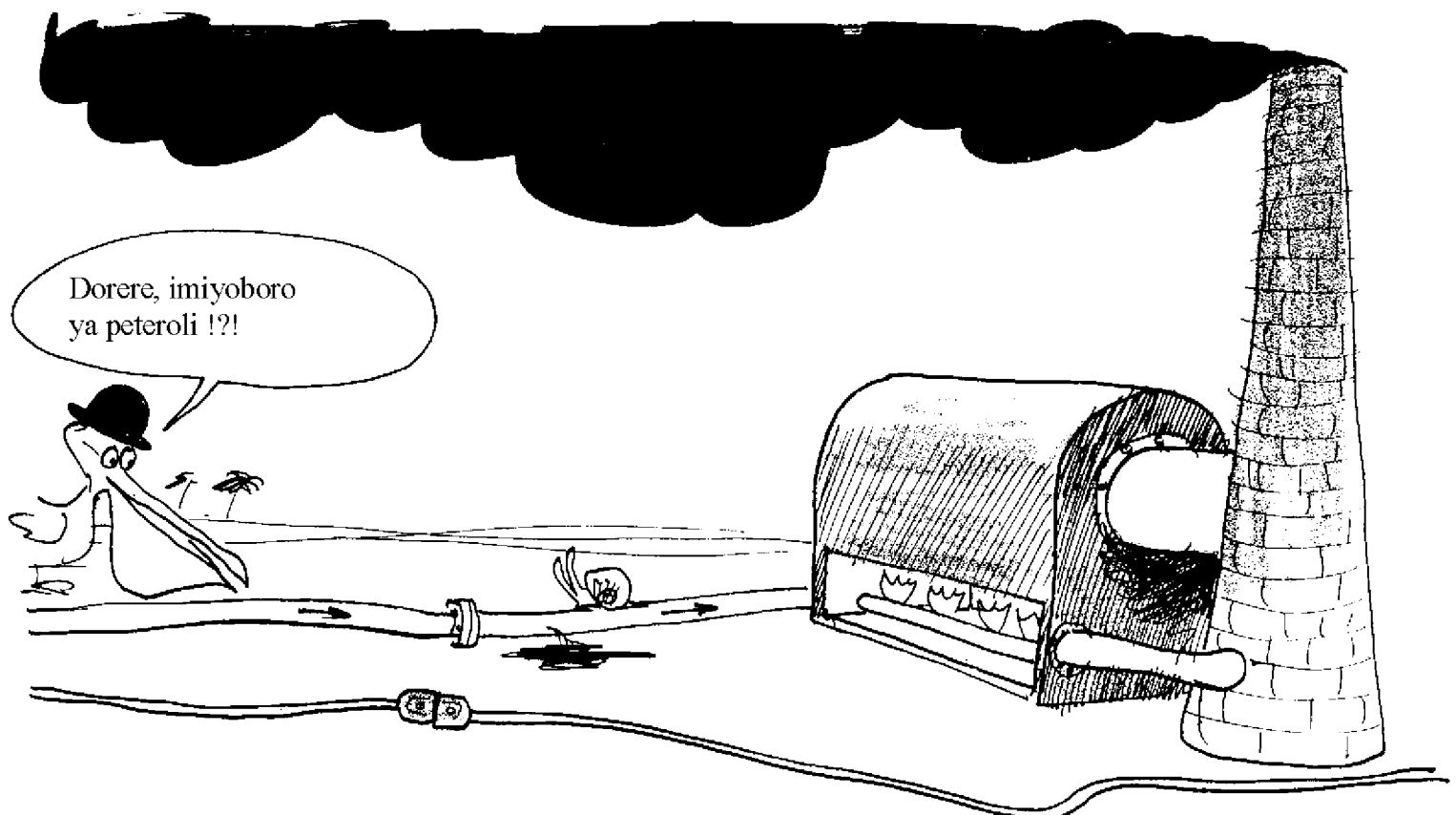

Ifuru ly'imashini y'ubukungu lyakishwa uru rubura rw'amazi, ruva mu karere ka kure k'ubutayo. Kuyazana ngo agere ino byaka ingufu nyinshi cyane (IMPAMYA BUGUZI BWA PETEROLI)



Noneho hali tiyo iva mu butayo ikagemulira hamana pompe y'ibigurwa (IGULISHA MU MAHANGA) (*)

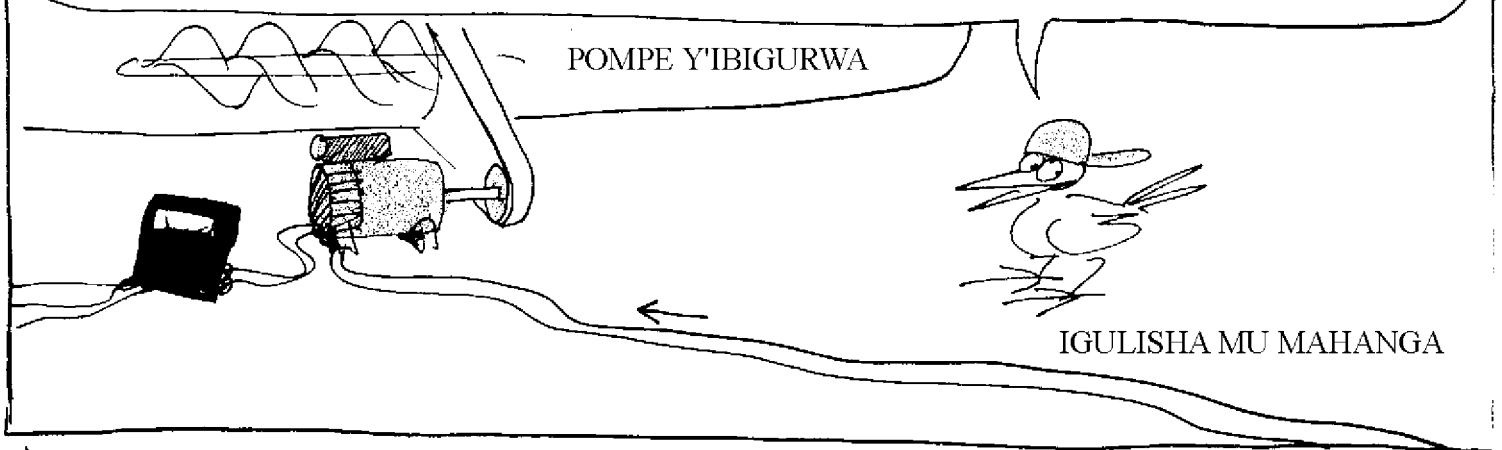

(*) IHUZA LY'UBUKUNGU BW'ISI YOSE tuzabuvuga mu gitabo kizakulikira : " L'inflatron international "

Dore, nguyo wa MUTERAMWAKU

Reka turebe amabaruwa



Yewe ga ...



Yewe ga ! ...



Bongereye ibiciro !

Ishishishi ! amazi natumbitsemo ibirenge byanjye alimo gukonja !

ICYO BISHYURA KUGIRANGO HABEHO



Birumvikana. Umuliro wose wigendara mu nzira Z'IBYO BISHYURA KUGIRANGO HABEHO IBYAGEZWEHO

IMPAMBA Y'AMAHINA

Yemwe ba sha, tulimo guta amaturu n'uguhaga k'umwuka kulimo kugwa

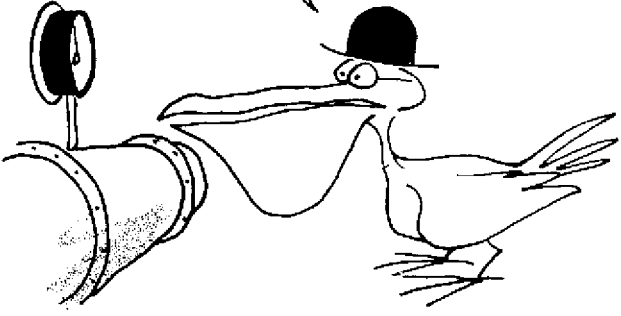

Bigenze bite ?



Fuluzemaker yafunze ibyumba by'ibyagezweho BITUNGUKA.

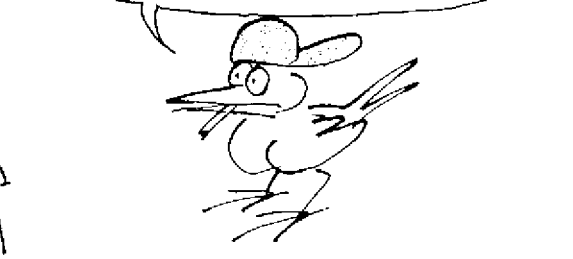

SHOMAJE iliyongera

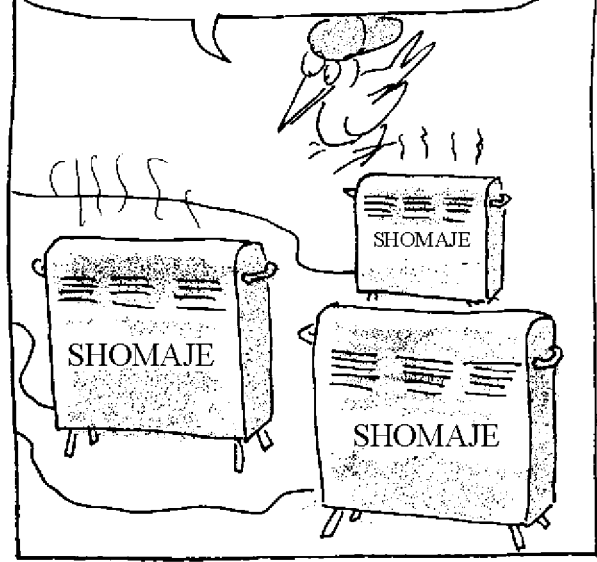

Ni ibiki ulimo gukora ?

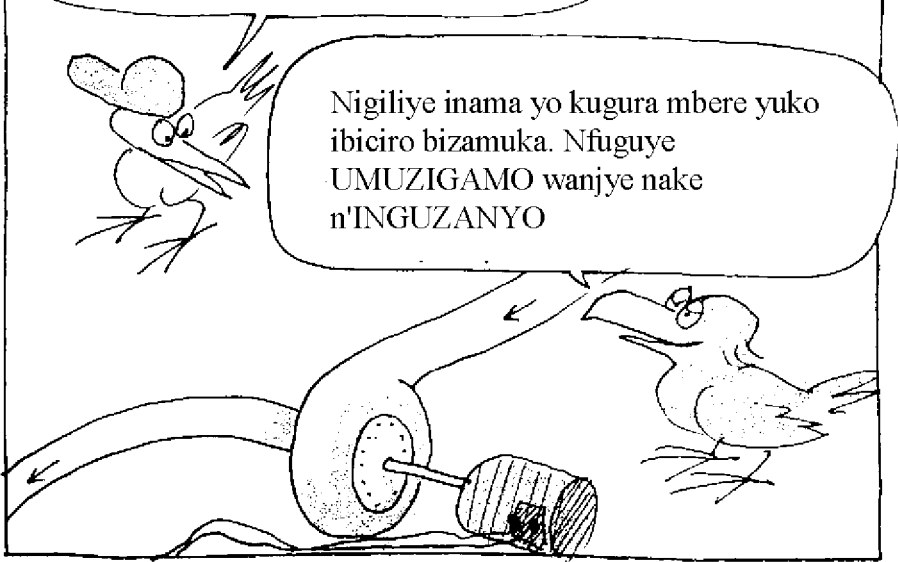

Nigiliye inama yo kugura mbere yuko ibiciro bizamuka. Nfuguye UMUZIGAMO wanjye nake n'INGUZANYO

Naho se Fuluzemaker we arakora iki ?

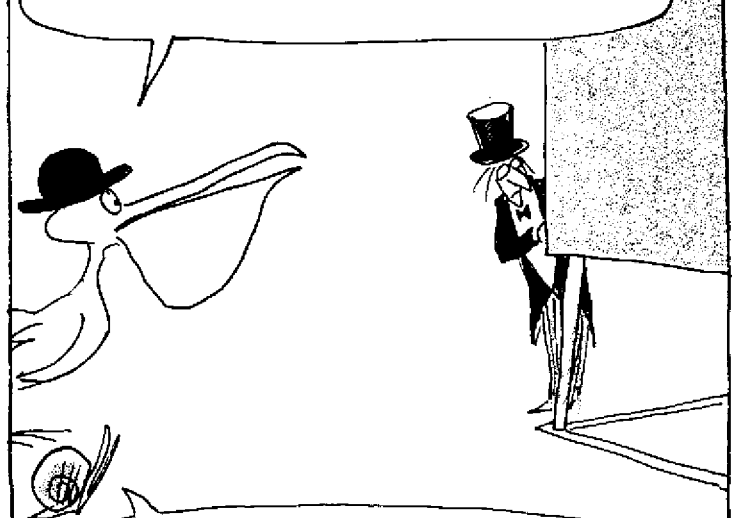

Ndatekerezako alimo kwinjiza rwihihwa umwuka mu nguguru ye (IZAMUKA CYANE LY'IBICIRO LITEWE NITANGA LY'INGUZANYO)

Biravugako Flouzemaker acura ... amafaranga ?



Oya, sibyo neza neza ... aliko ubwo bulyo bw'amabanki, izo mpapuro zose, izo nyemera z'inguzanyo ... ibyo byose bigera aho bigasa nk'amafaranga. Umunsi umwe, hagize uwoza ingunguru ya Flouzemaker twabona ibitangaza ...

Kwitabaza INGUZANYO no guta ICYIZERO byasalishije IBIGURWA noneho ibiciro BIRASARA ...

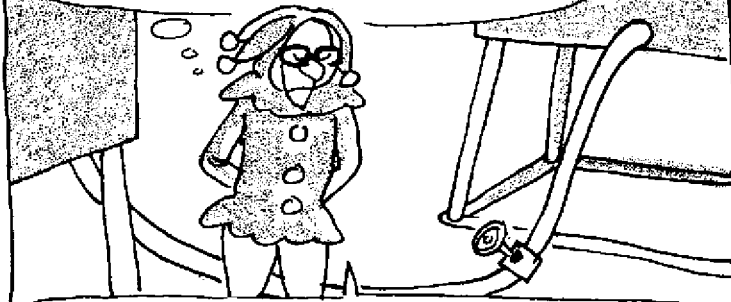

Ilyo lyirukira kwaka inguzanyo ligomba guhagalikwa

Fuluzemaker aguliza FULUZE nyinshi abantu. Aliko nanjye ndayimuguliza.

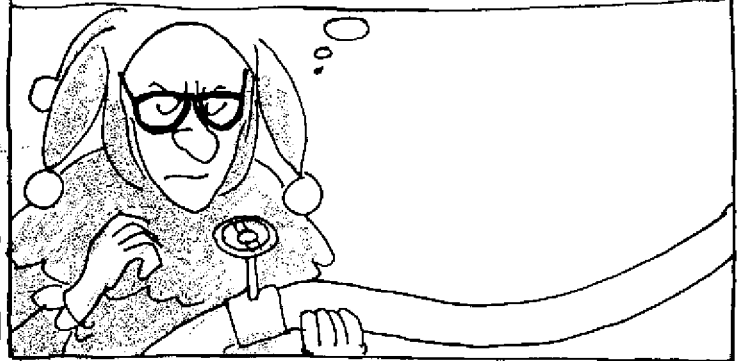

Noneho se buli muntu afite uwo aguliza ?

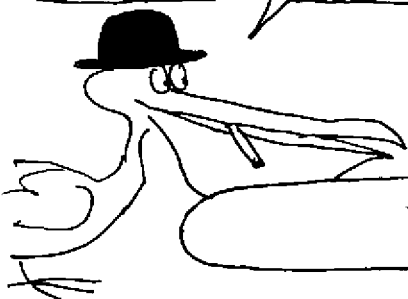

Yewe, urabizi, muli izo gulizana halimo impuha nyinshi

Ngiye kugabanura inguzanyo namuhaga biratuma abanza agatekereza mbere yo kuguliza uko abonye ...

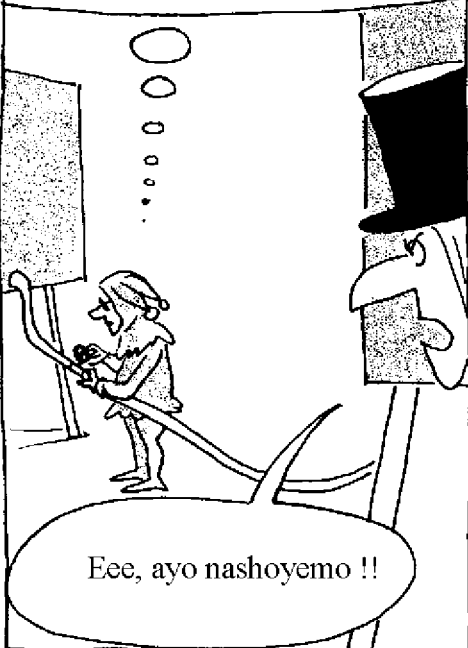

Eee, ayo nashoyemo !!

Yee. Twahagalitse gato icyo kibazo cy'inguzanyo. Aliko mu BUBIKO BWA LETA ibintu biragabanuka huti huti ...

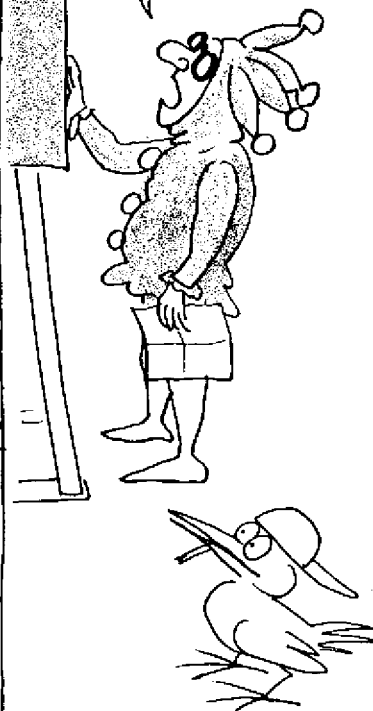

Umuntu yabigira ate ? Kongera imisoro yo ku mutungo ? ... imisoro yo ku bundi bukungu ... imisoro yo ku nyungu z'ubucuruzi ? ...



Imisoro yose ...

Turashaka ko umuvuduko yongerwa !

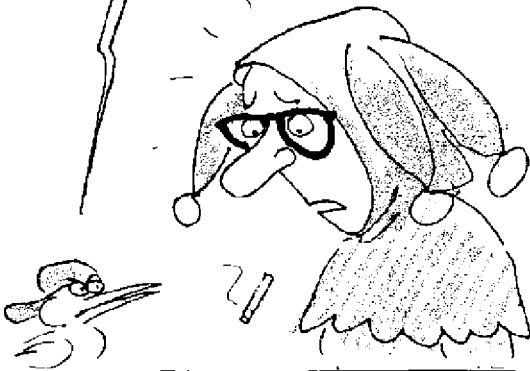

Bwana MUTERAMWAKU,
ihaga mu matiyo ilimo kugwa,
BAROMETERO yamanutse

Umubiko urenda kuduhamagara !

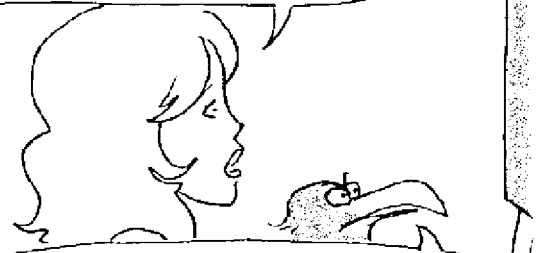

Ninde wanshyiliyeho iki kintazi !?!

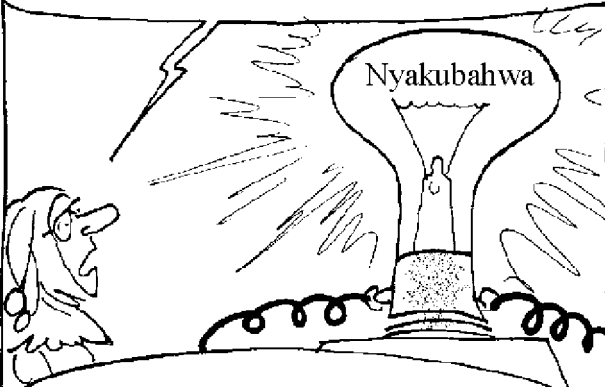

Ni itara linini likoreshwa n'amashanyarazi
ligemulirwa n'umubiko wa leta.

Bigatuma batubonera kure

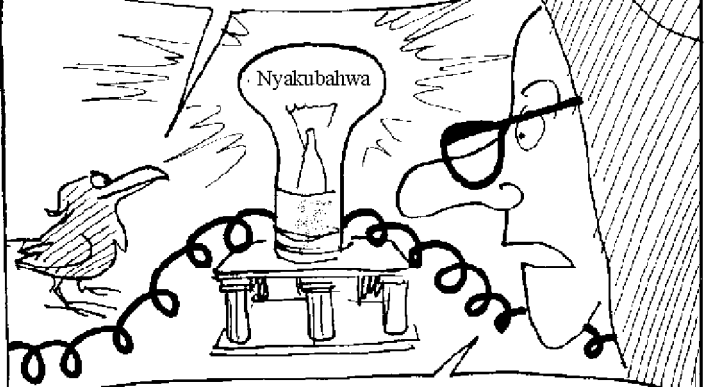

Yee ! ? Lizimye vuba cyangwa uradutemesha !

Ubwiyongere bw'umuvuduko
cyangwa turekeraho
KUZUNGURUTSA

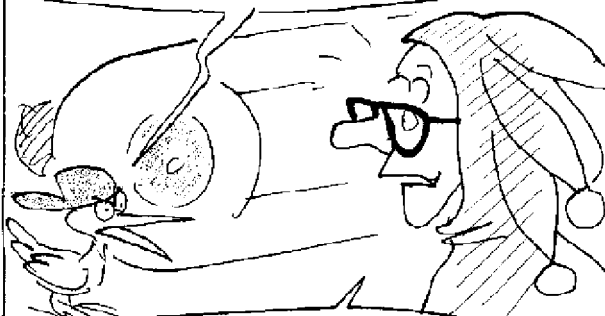

Yego, yego ... muli aka kanya

Hasigaye igisubizo kimwe gusa

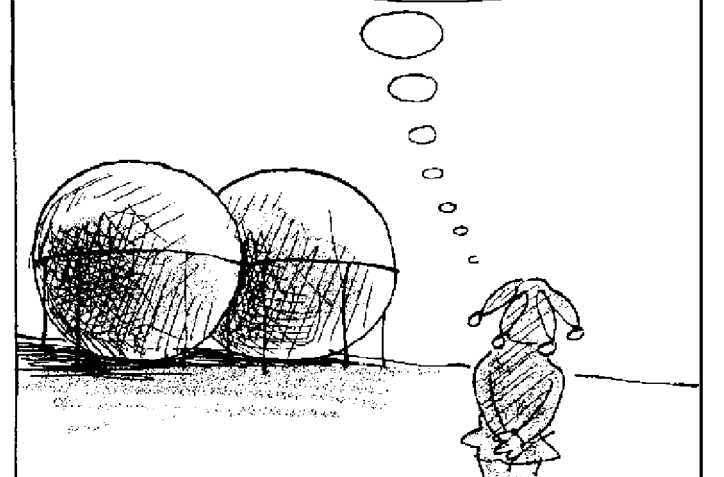



MUTERAMWAKU arakora iki ?

Alimo gucomeka ibingunguru binini cyane aho FULUZE inyura

Akongera kuzuza UBUBIKO BWA LETA

Izi ngunguru zibaye zibitswe ni nini cyane, biraturema umutima. Aliko se halimo iki ?

Sinakubeshya

Aha, ngaho bashyize bongera umuvuduko. Bali batinze !

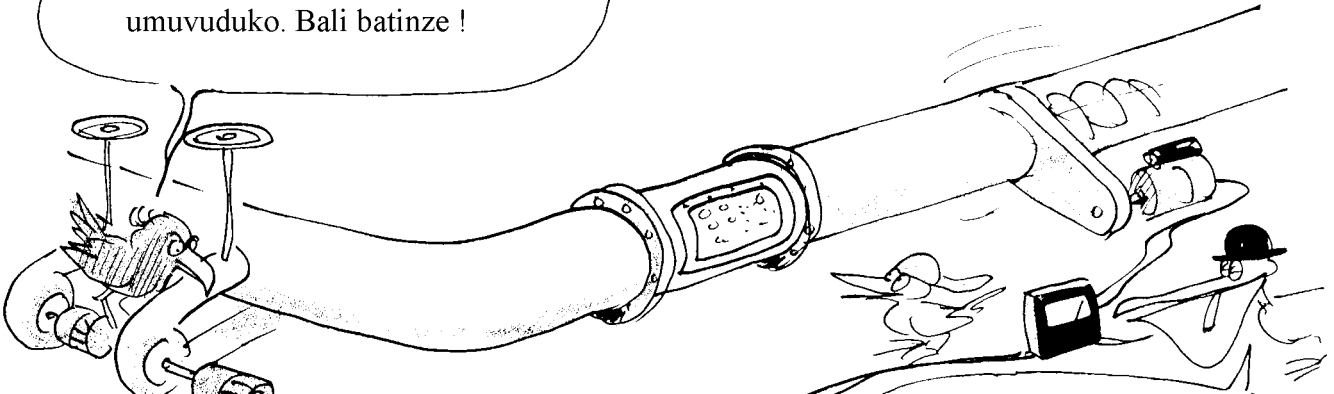

Mbega uburemere. Pompe y'ibigurwa irakora byasaze

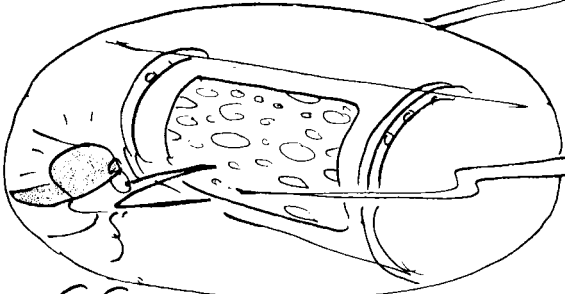

Yewe, itonde ! Ibiciro !!!

Ske, ntacyo, imashini irushijeho gukora neza,
amapompe aratanga umuvuduko mwiza

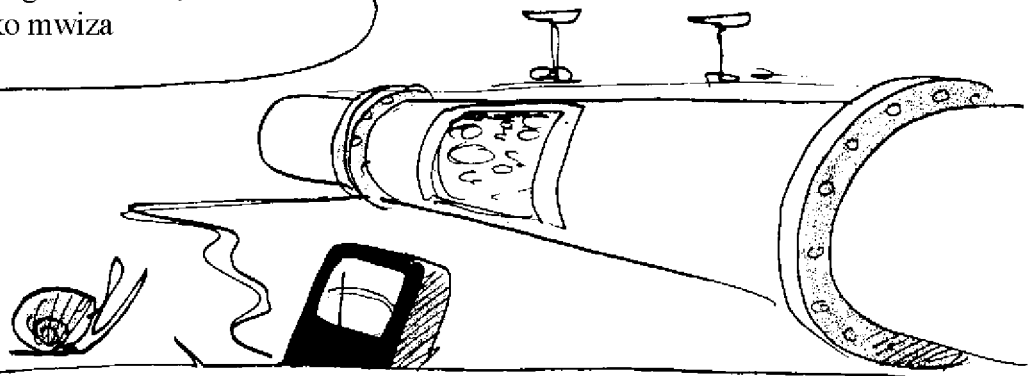
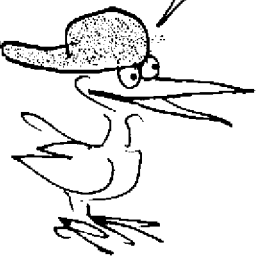

Yego, aliko reba : imiremere ilimo kugabanuka ahantu hose !

Hali ikitagenda. Ilingi lirazenguruka,
lyahejeje mu muvuduko, aliko ntihagire
icyo bitanga



Ni iki MUTERAMWAKU yashyize
mu mugezi w'ubukungu ? ! ?



Reka tujye kureba izo nguguru

Urugi ?

Reka twinjire

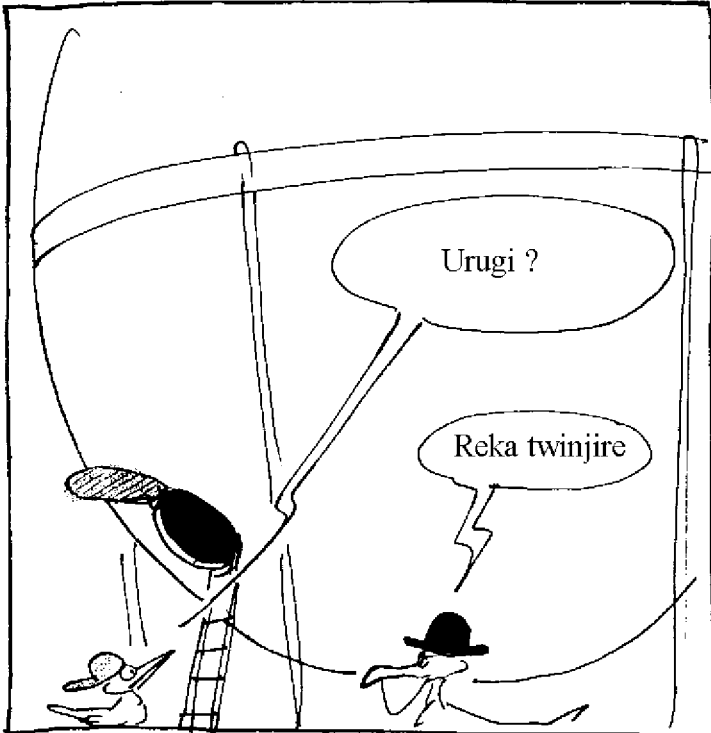

Zilimo UBUSA !!!

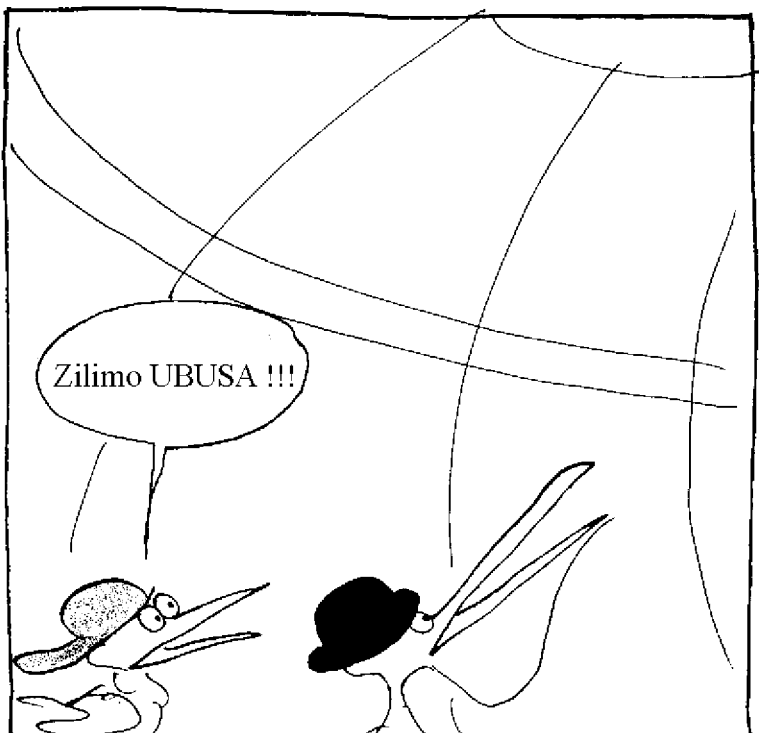

Uravuga ko izi ngunguru nazo UBU zashize ?

Oya, ntacyigezemo, igihe cyose ZALIMO UBUSA !

Bimeze nk'iyo NTA BUKUNGU ?

Ni UBUSA nya busa ?

Iyo ntakigenda, ABATERAMWAKU bose babigenza kimwe. Batera urushinge rw'umupira munini w'IMPUHA mu matiyo. Bikabanza bigasunika FULUZE, ni nkaho bayiteye AKANYABUGABO

Aliko FULUZE igeraho ikivanga, maze igata uburemere

Ibiciro bikazamuka

UMUZIGAMO ugata agaciro

Ayiwe, nanjye ngiye kubikuza umuzigamo wanjye

N'umutahe nawo ...

FLOUZEMAKER !

Guhungisha umutungo mu mahanga !
Mbega umusenzi !!!



Tuhagereye igihe ! ...



Fuluzemaker,
nkeneye imitahe yawa



Wikigira nk'umwana !

Yagiye he ?

Yemwe, yakonje
urubura !!!



Yasize yanditse ...



Ntimwongere imishahara, mugabanure imisoro
ku nyungu z'ubucuruzi, impamba y'amahina
kandi mutange imfashanyo kubashaka gushora imali.

Mor Fuluzemaker

Aliho se... , ubushobozi bwo kugura bugiye kugabanuka. Abantu barakare.
Noneho pompe y'ibigurwa ite amaturu yo kuzenguruka.

Reka tubanze tuzigame gato ilyo shyano lya peteroli !

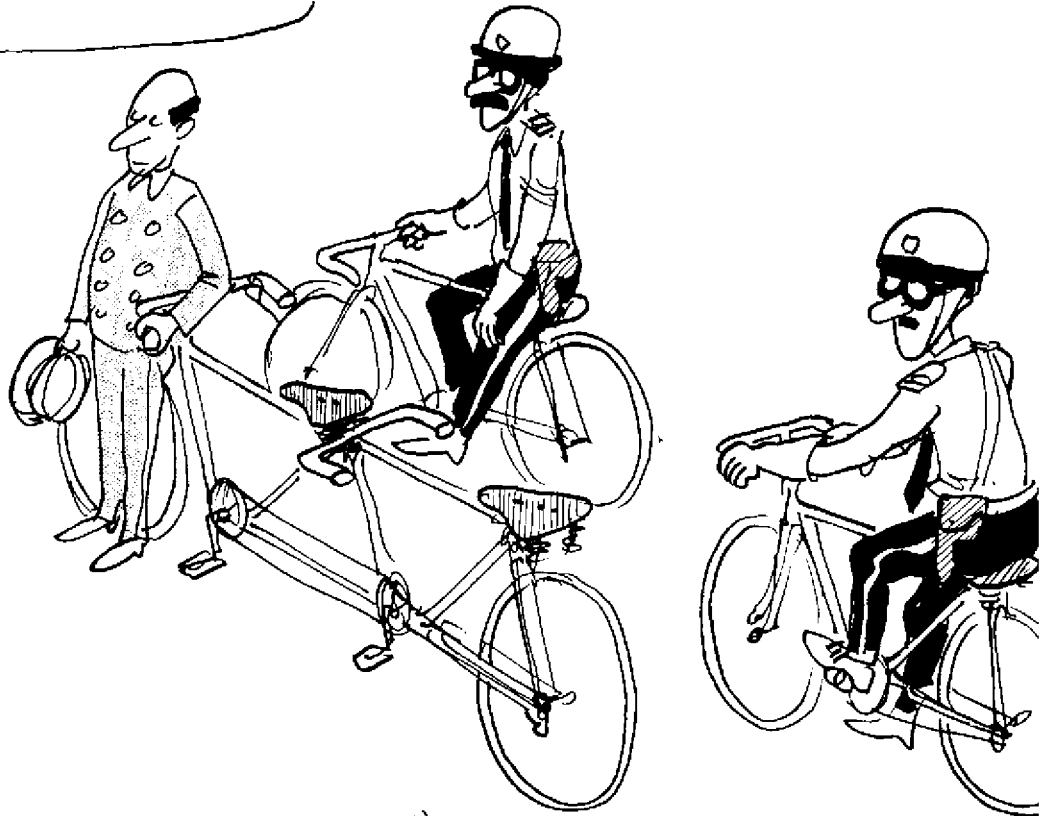
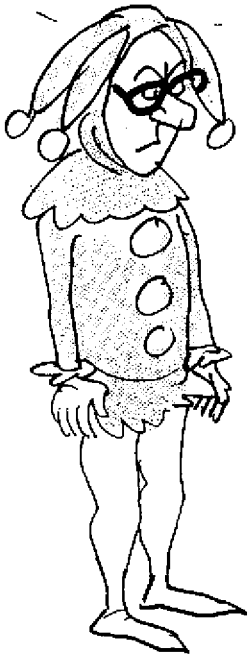

FULUZE yataye agaciro. Ily'iyongere ly'umuvuduko !!

Twe, twali twarabivuze !

Birakabije !

Igihombo adashobora gusimbuka ! ...

Kandi igihe nali MUTERAMWAKU byali bibi kurushaho ...

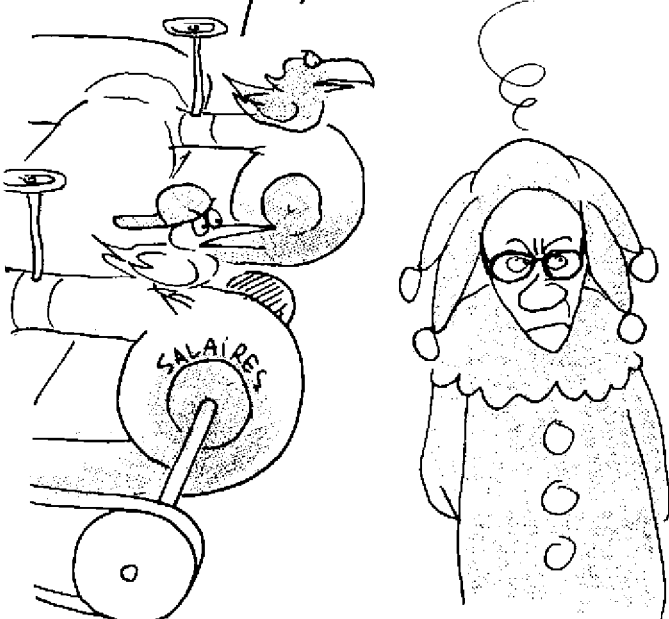

Dorere, ikindi cyumba
cy'ibyagezweho bacomokoye

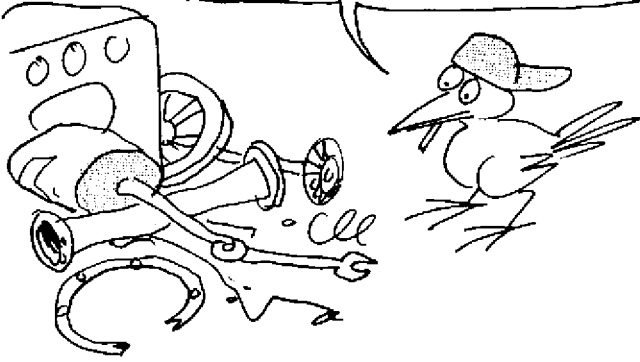

Bagombye kubaka
ikindi... ibindi byinshi
cyane ...



Bwana MUTERAMWAKU ...

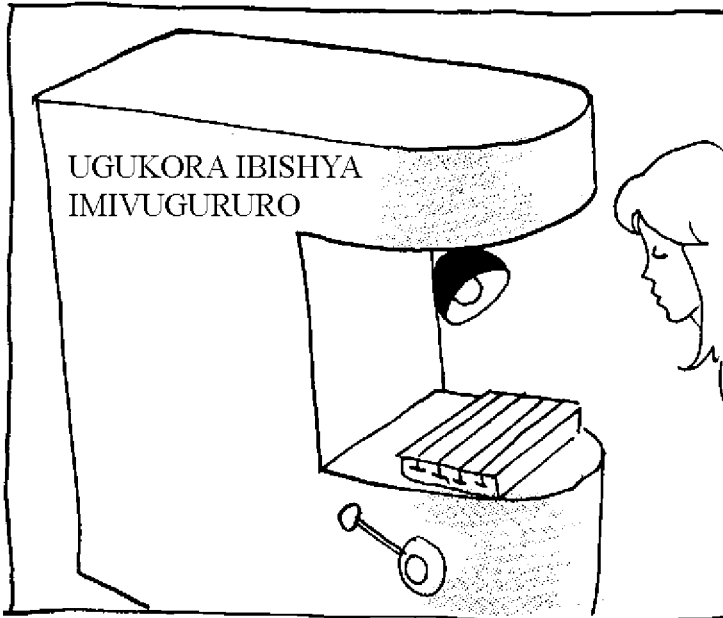

Uwakongera ngashinga indi minisiteri ? ...
cyangwa sekretariya ya leta ? ...

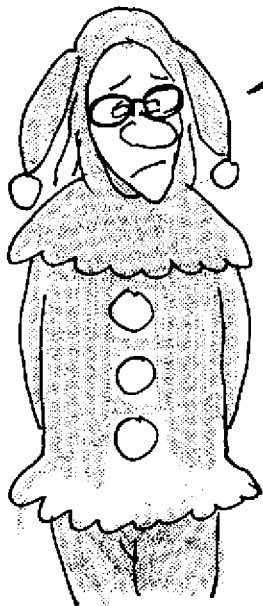

Ye ?

Bwana MUTERAMWAKU, igisigaye cyonyine ni ugutera
amaguru ya sarwaya. Tugomba GUKORA IBINTU
BISHYA, gutekereza ibyuma by'ibyagezweho
bivuguruye.



Tugomba gutera imbere mu BUHIMBYI.

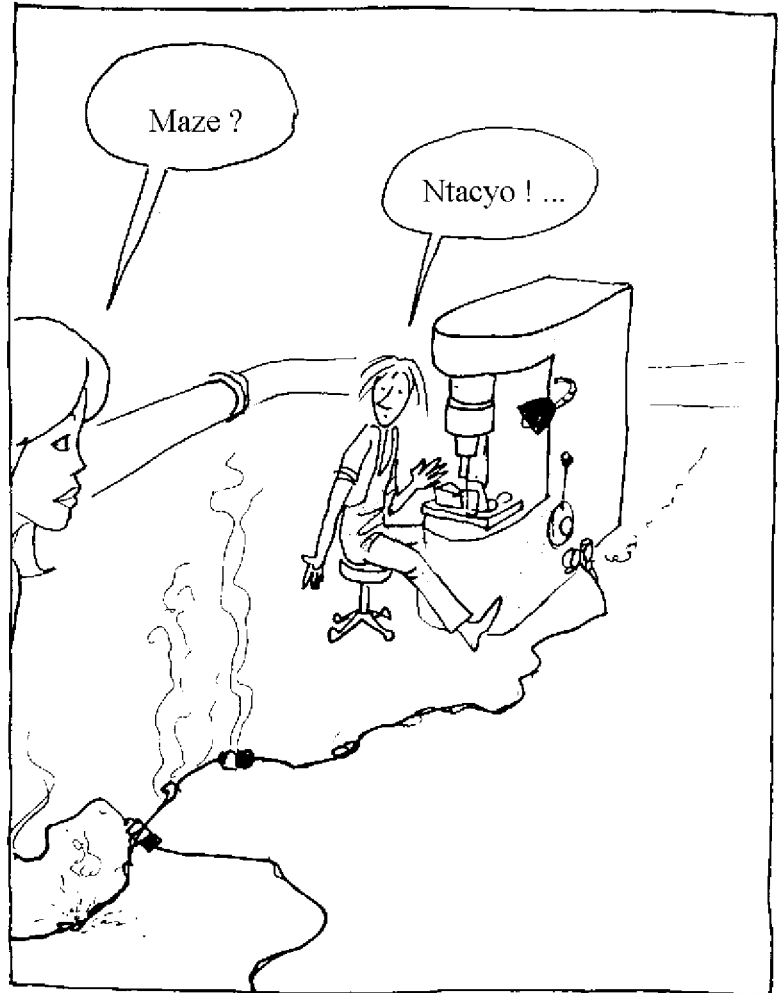
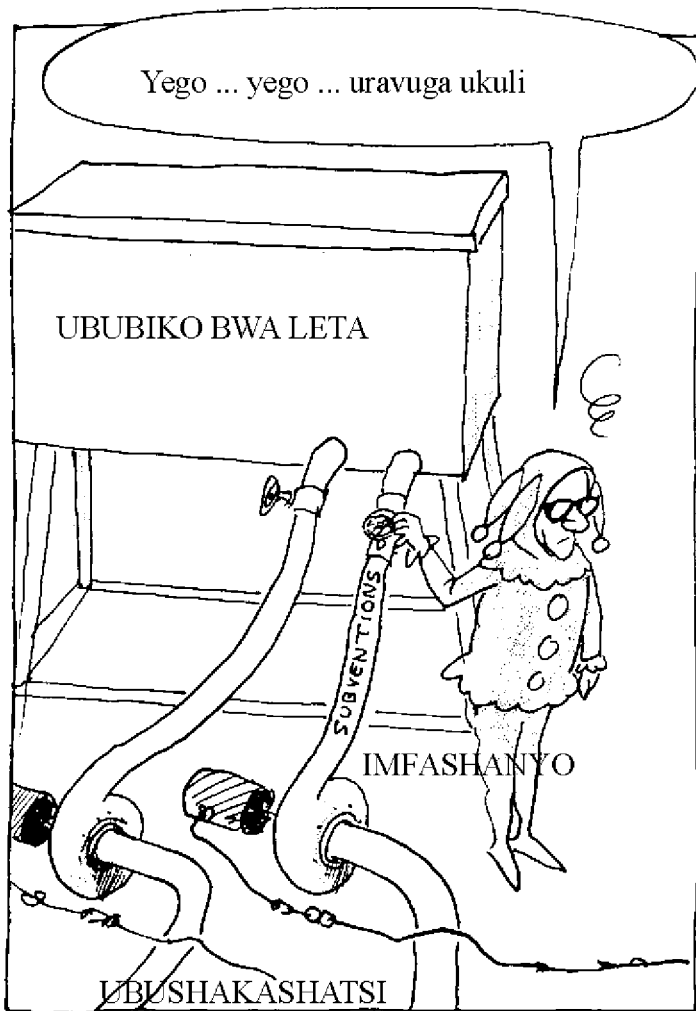

Ibyago mu gihugu cyacu ni ibyo DUTAKAZA MU MAYIRA ...



Sinje wahera