

Ingyendo nshakisha z'Anselimi Lanturulu

TOPOLOJIKONI

Yohani-Petero Petit

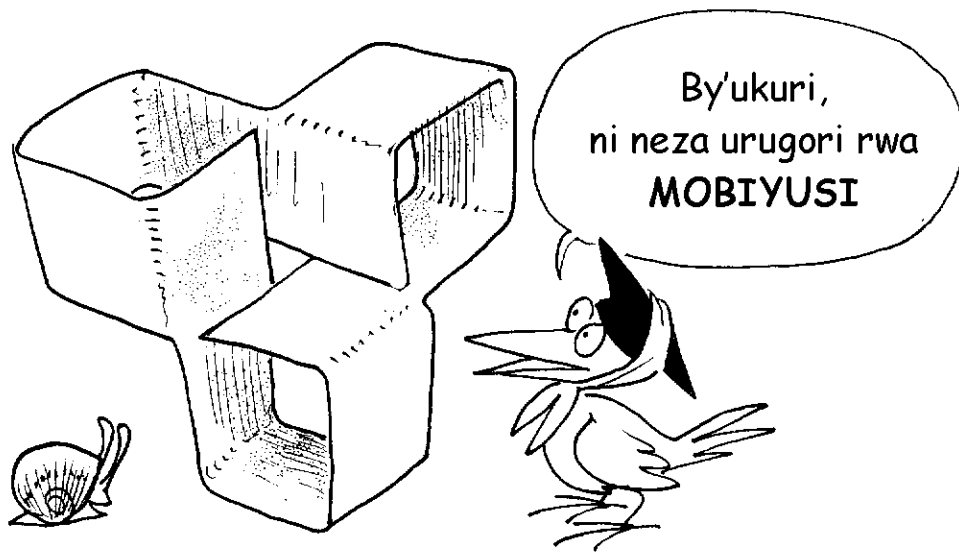

<http://www.savoir-sans-frontieres.com>

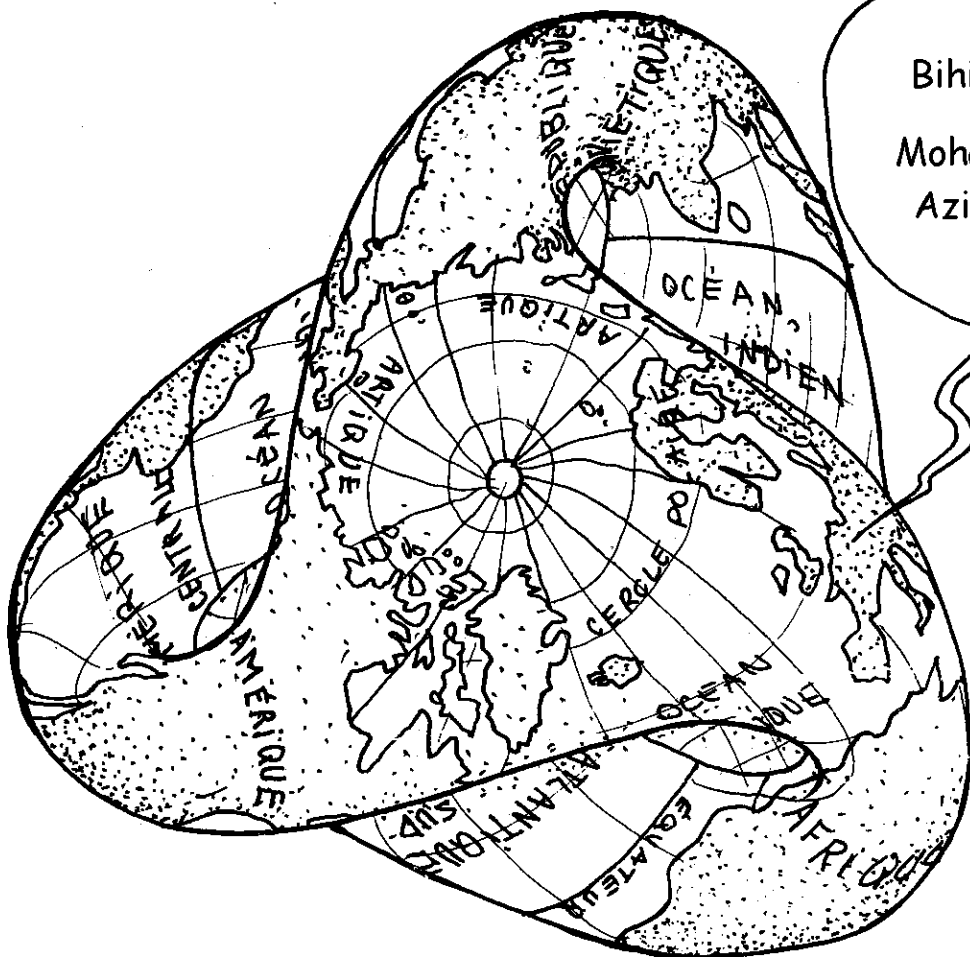

Bihinduwe na:
Mohamed Abdel
Aziz Kamanzi

Ubumenyi butagira Imipaka

Itegeko ryo mu 1901 rigenga amashyirahamwe

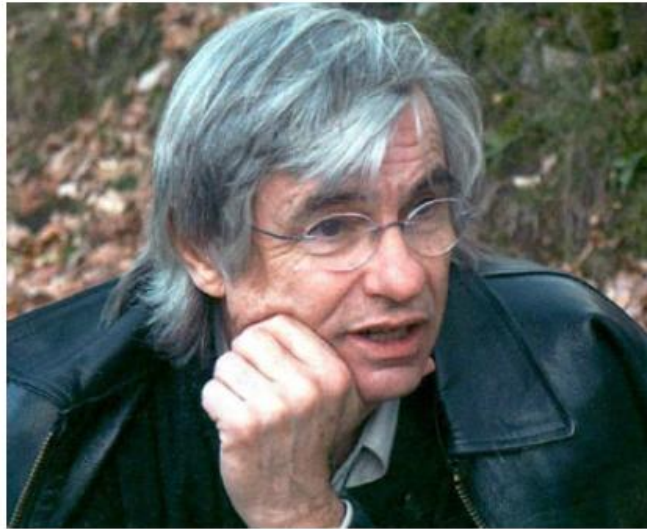

Jean-Pierre Petit, Perezida w'iri Shirahamwe

Uyu Jean-Pierre Petit, Peresida w'iri shyirahamwe ry'Ubumenyi butagira Imipaka, yahoze ari diregiteri w'ubushakashatsi mu kigo cy'inzobere cya CNRS, mu Bufaransa. Akaba kandi inzobere ihanitse muri Fizike y'inyenyeri (Asitorofizike); yahimbye uburyo bushyashya by'inyandiko bita: *Ibitabo by'amashusho by'ubumenyi*. "Ubumenyi butagira Imipaka" ni ishyirahamwe ryahimbwe mu 2005 n'abagabo babiri, Jean-Pierre Petit na mugenzi we Gilles d'Agostini. Iri shyirahamwe ryihaye intego yo gukwirakwiza kw'isi hose ubumenyi ku buntu harimwo n'ubumenyi bwa tekhnike, ubukorikori n'ikoranabuhanga. Iri shyirahamwe ribeshejweho n'inkunga rihabwa. Izo nkunga nizo ziriha abantu bahindura inyandiko mu zindi ndimi. Buri nyandiko (igitabo cy'amashusho cy'ubumenyi) ihindurirwa mu rundi rurimi ku mafaranga angana n'amayero 150 (150 euros) kuva mu 2007 kugeza ubu. Iri shyirahamwe rinariha amafaranga ajyanye n'iyoherezwa ucishije muri banke ry'ayo mafaranga y'ihinduranya mu zindi ndimi. Abahinduranyi b'indimi bagiye bongera, buri munsu, umubare w'ibyo bitabo bisomwa hose k'ubuntu. (Nko kugeza mu 2007, hari hamaze kuboneka ibitabo magana abiri (200) bikurwa kuri interineti k'ubuntu kandi byanditse mu ndimi makumyabiri n'umunani (28) harimwo ikinyarwanda n'ururimi rwo muri Lawosi).

Biremewe ko iki gitabo gikopororwa cyangwa gifotorwa, cyose cyangwa igice; kinakoreshwa n'abarimu mu masomo ariko mu buryo butari uburya inyungu z'amafaranga. Gishobora gushyirwa mu masomero y'uturere, y'amashuri cyangwa ya za kaminuza, cyanditse ku mpapuro cyangwa cya shyizwe mu miyoboro y'imbuga z'ikoranabuhanga zigose (intranet).

Uyu mwanditsi w'ibi bitabo yatangiye kwandika ibindi byo byoroshye kandi bigenewe abana bato (bari mu rugero rw'imyaka 12). Ibindi biriho bikorwa n'ibitabo by'amajwi avuga, bigenewe abatazi gusoma cyangwa abashaka kwiga urundi rurimi rutari urwo bakuriyemwo.

Iri shyirahamwe rishaka buri gihe abahinduranyi b'inyandiko bazishyira mu ndimi zabo zakavukire ariko bafite ubuhanga buhagije bwo gutanga inyandiko mpiduranyi nziza z'ibitabo basomye.

Ushatse kugira icyo ubaza cyangwa ugeze kuri iri shyirahamwe, wajya ku rubuga rwaryo ku interinete aha hakurikira: <http://www.savoir-sans-frontieres.com>

Iranga-konti mu Bufaransa → Inyandiko ngaragaza mutungo muri (RIB)

Ikigo	Umwanya wo kwakiriramo amafaranga	Nimero ya konti	Urufunguzo rwa RIB
20041	01008	1822226V029	88

Aho ikorerera: Banki ya Posita
Hagati y'Umujyi wa Marseille
13900 Marseille CEDEX 20
Mu Bufaransa

Mu bindi bihugu → Ibanki Mpuzamahanga (International Bank) Nimero ya Konti (IBAN):

IBAN
FR 16 20041 01008 1822226V029 88

→ N' Inyandikobanga ya banki (BIC) :

BIC
PSSTFRPPMAR

Amategako agenga iri shyirahamwe agaragara ku rubuga rwa yo kuri interineti. Imibare ngaragaza mutungo nayo irahari kandi ihora ishyirwa ku gihe. Iri shyirahamwe nta mafaranga na make rikura ku nkunga rihawe uretse ayo kohereza, bicishijwe muri banki, ahemba abahinduranyi b'indimi ku buryo babona abagenewe yose. Nta munyamuryango w'iri shyirahamwe n'umwe rihemba kuko bose ari abakoranabushake.

Abanyamuryango ubwabo nibo barihira amafaranga ishyirahamwe rikoresha ngo ribeho nk'ayo kwishyura no gukoresha urubuga rwa yo rwo kuri interineti kuko ayo atarihwa n'ishyirahamwe.

Bityo mugaragarizwa neza uko umutungo w'ishyirahamwe ukoresheka kandi mukibonera ikizere ko, muri iyo "mirimo y'ubwitange mfashamuco", inkunga yose mutanga ikoresheka neza mu kwishyura abahindura ibitabo mu zindi ndimi.

Dushyira ku rubuga rwa interineti buri kwezi, ugereraniye, nk'ibitabo cumi bihinduwe mu zindi ndimi.

Ikitonderwa ku basomyi

Byaba byiza mudasomye iyi alubomo :

- Nimugoroba mugiyeye kuryama
- Mumaze kurya ibiryo bitubutse kandi by'intungamubiri nyinshi
- Cyangwa igihe umangamanze mu mutwe, kuko bihita bibyunura.

Umwanditsi.

PALANETE itAGIRA POLE Y'AMAJYEPFO

TWAVUMBUYE POLE Y'AMAJYARUGURU !

Ishimwe ryinshi Bwana PERI

Hmmm...
nsigaje pole
y'amajyepfo

AAA...TCHOO !

Ni byo, ni byiza, ariko Jyewe,
Amundeseni, ndagiye kuvumbura
pole y'amajyepfo !

Hmm...kujyana umugore
mu rugendo nkuru rw'ubushakashatsi,
ibyho byanvuna...

Ngiyeye
gukurikirana
MERIDIYE

Jye na bagenzi
banjye, dushobora
kwandika amateka
yanyu, tukanavuga
ubushakashatsi
bwanyu.

Dushobora
kujyana na we ?

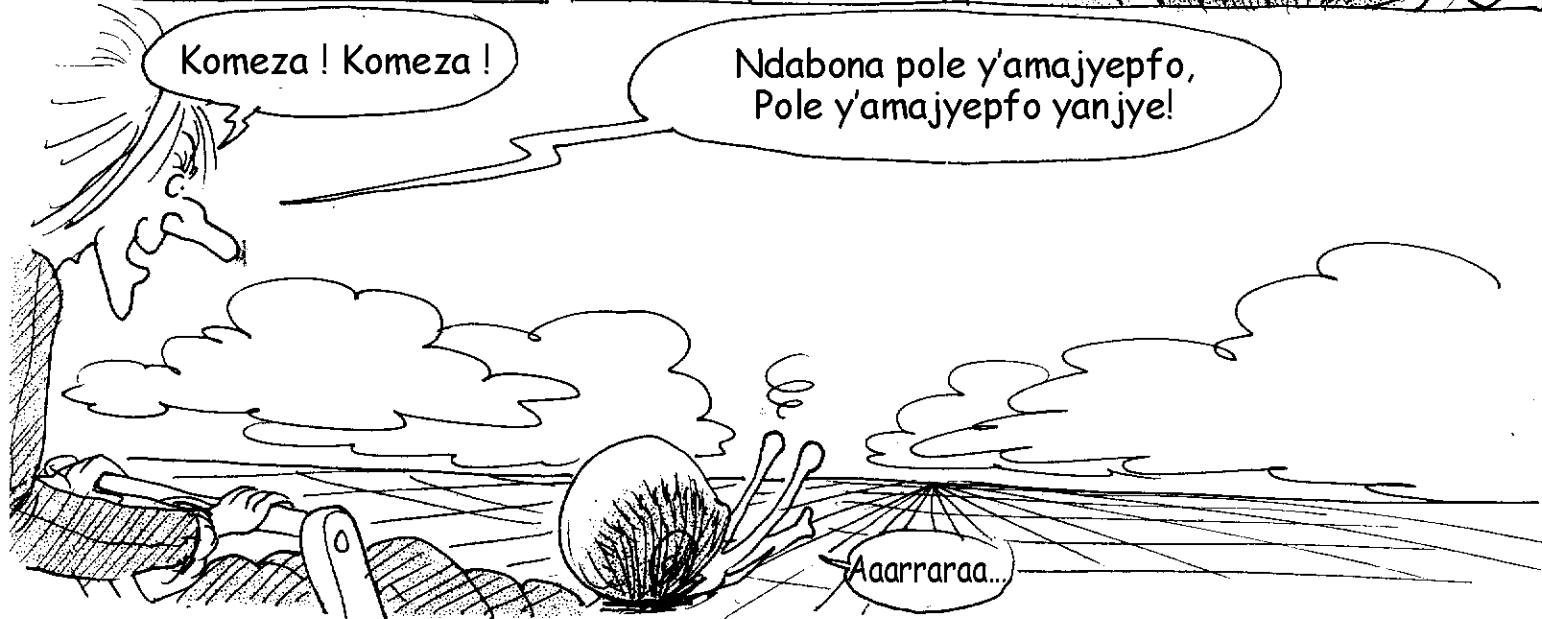
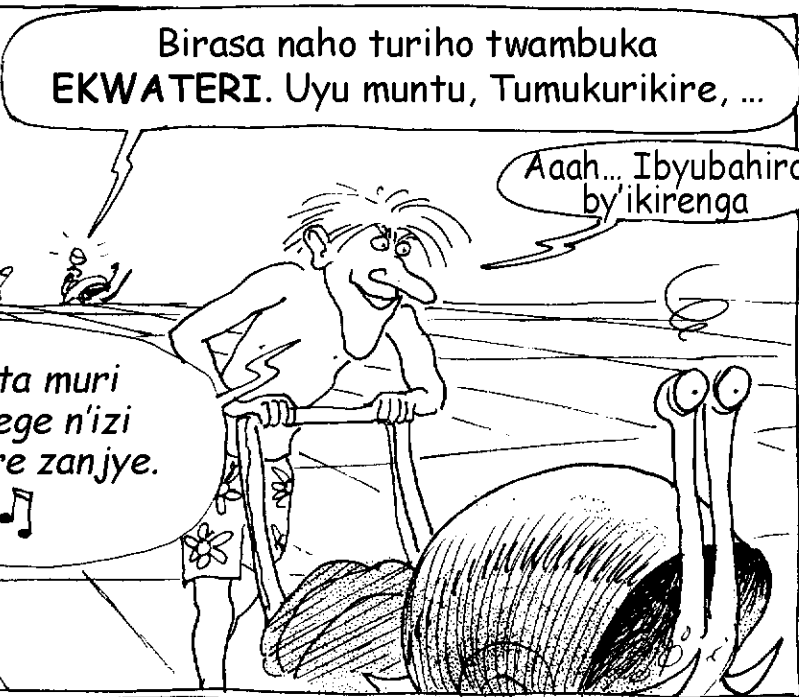
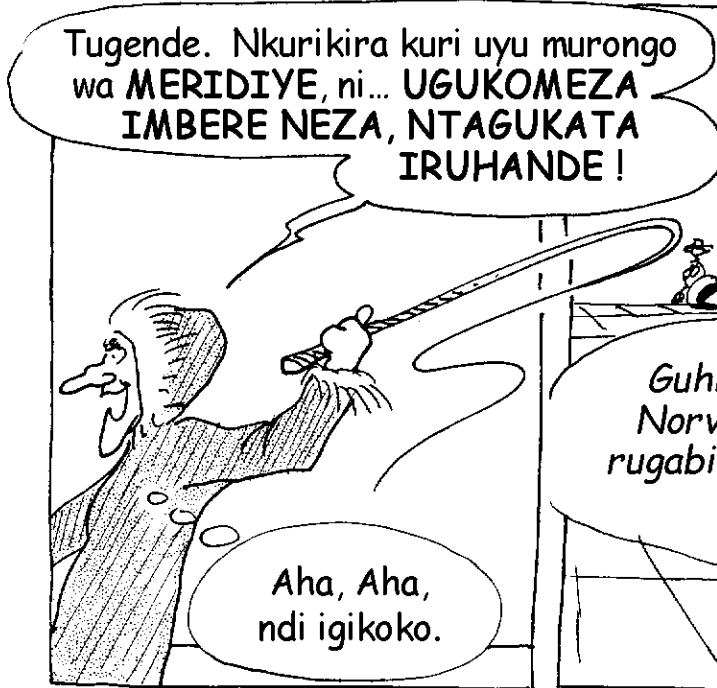
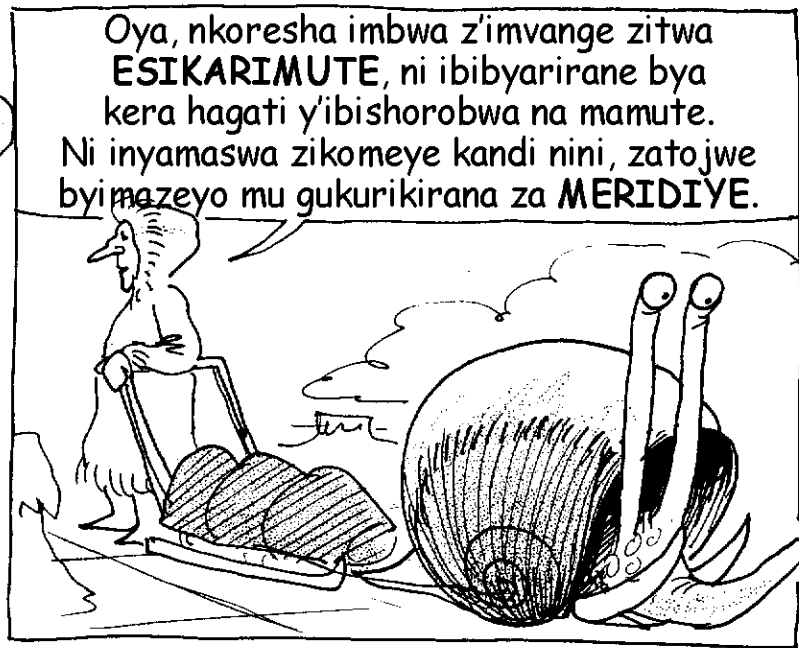

Ndi uwambere...

IBYUBAHIRO
BY' IKIRENGA !



Ariko !?
ibi ni ibiki ??



Iyi byenda
kunsetsa ni
bwoko ki ?



Eheee !?

Aho ra!



OROROROO !

KKRAK



Ngibyoo !
Hari ufite icyo yongeraho ?

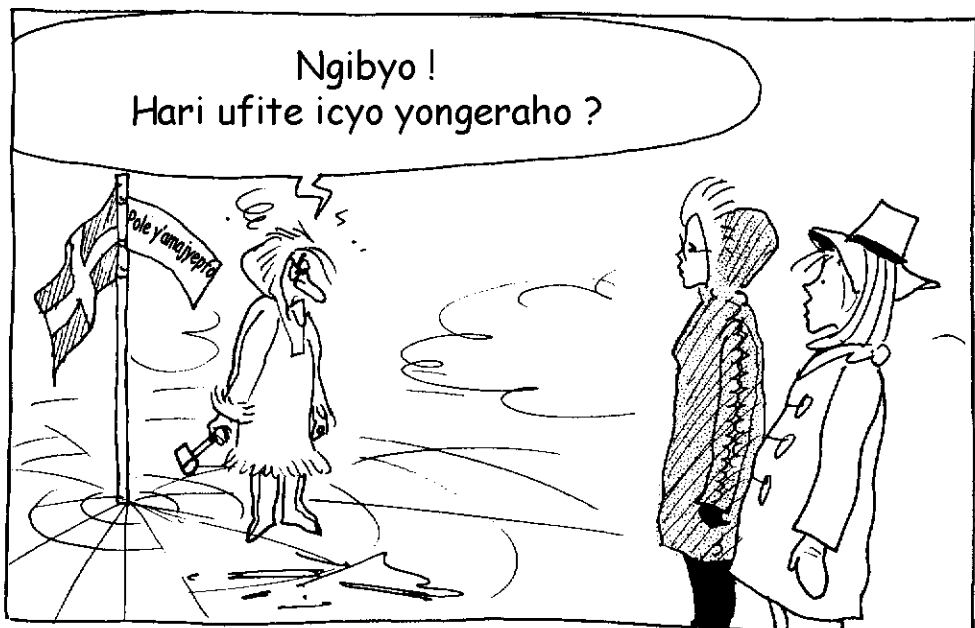

Nta numwe ufite
n'akajambo kajyanye
n'ibi ngo akatugezeho!

Hee,
Urambonera !

Tuza, Bwana Amundeseni

Idarapo ryanjye !
Rirabuze !!!

Iki !!?!

Vuga, mwavanye ubwo
bugoryi bwanyu aho ?

Biteye amatsiko...
wagirango ni ijwi rya
Bwana PERI

TONK
TONK
TONK

Turikumwe Bwana Amundeseni,
tugiye gutaha rero.

Mbega
gutungudwa!

Tugiye
kugerageza
gusobanura ibyo
byose.

ARGL...

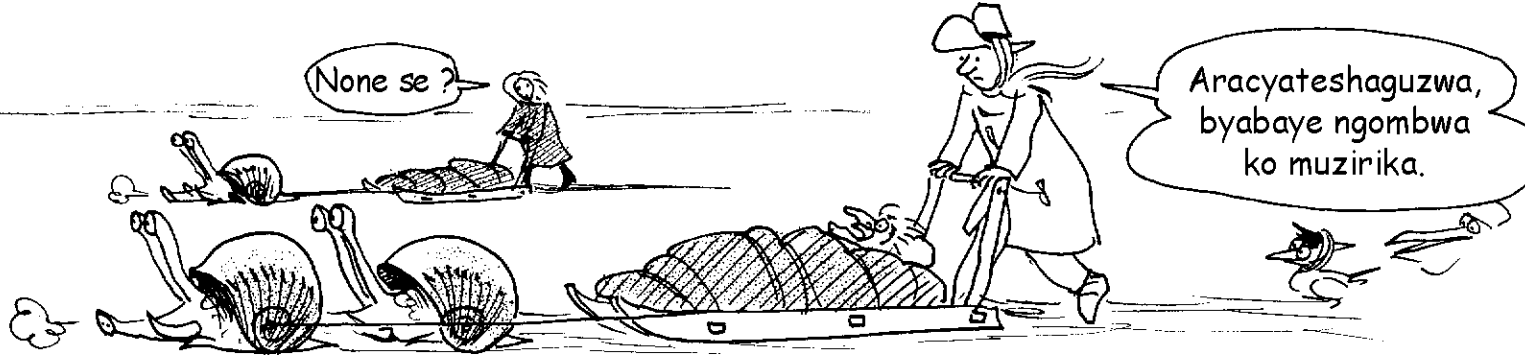

Esikarimute ziranyerera bucece kuri meridiye zikonje cyane.



Igihe mutari muhari habaye ikintu gitangaje. Idarapo ryanjye ryagize gutya rirarigita noneho nza kubona irindi ryahashinzwe ryanditseho « POLE Y'AMAJYEPFO » !!

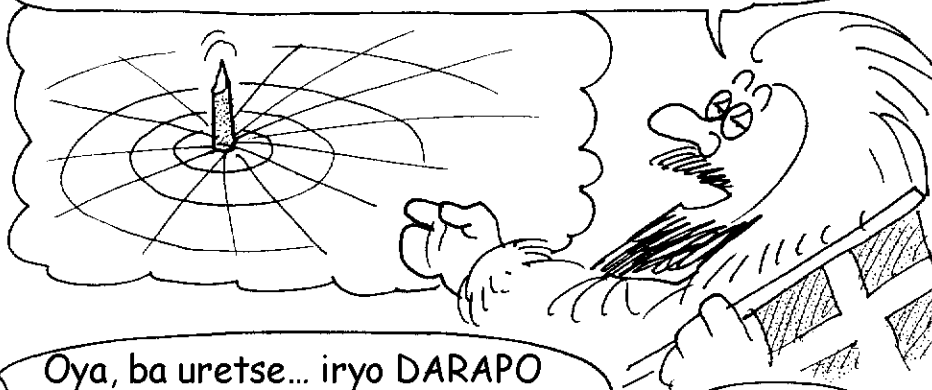

Ibyo byose ni ibintu bitumvikana na busa !

Ni byo, ariko se ubizi ute ?

Ndumva ntangiye kubisobanukirwa noneho.

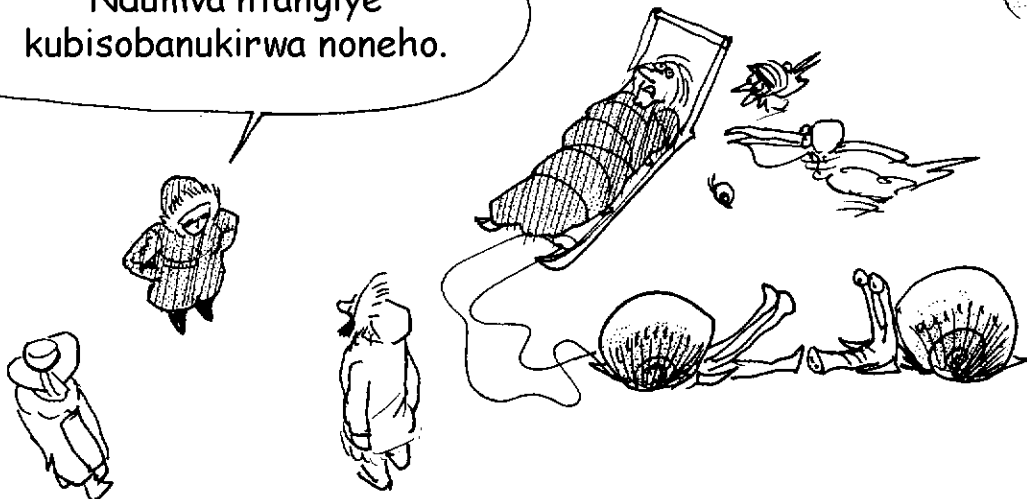

Ni ibintu bigaragara rwose, niba tugereranije ko **AHEGEREYE** iyo meridiye twakurikiye hateye nk'ubusitani bw'uruhande rumwe (*), u **RUGORI RWA MOBIYUSI**, rw'uruhande rumwe (reba **JEOMETRIKONI**, icapiro **BELIN**, ipaje ya 54)

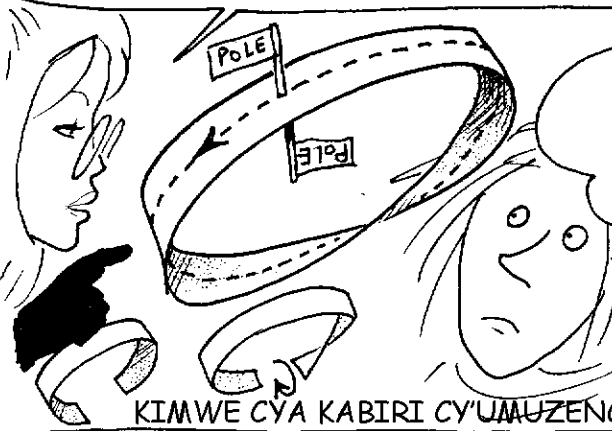

Urashaka kuvuga ko pole y'amajyepfo aho twari turi mu mwanya ushize atari incuramike ya pole y'amajyaruguru ?

Ariko se, pole y'amajyepfo **NYAYO** iba **HE** ?

KIMWE CYA KABIRI CY'UMUZENGURUKO

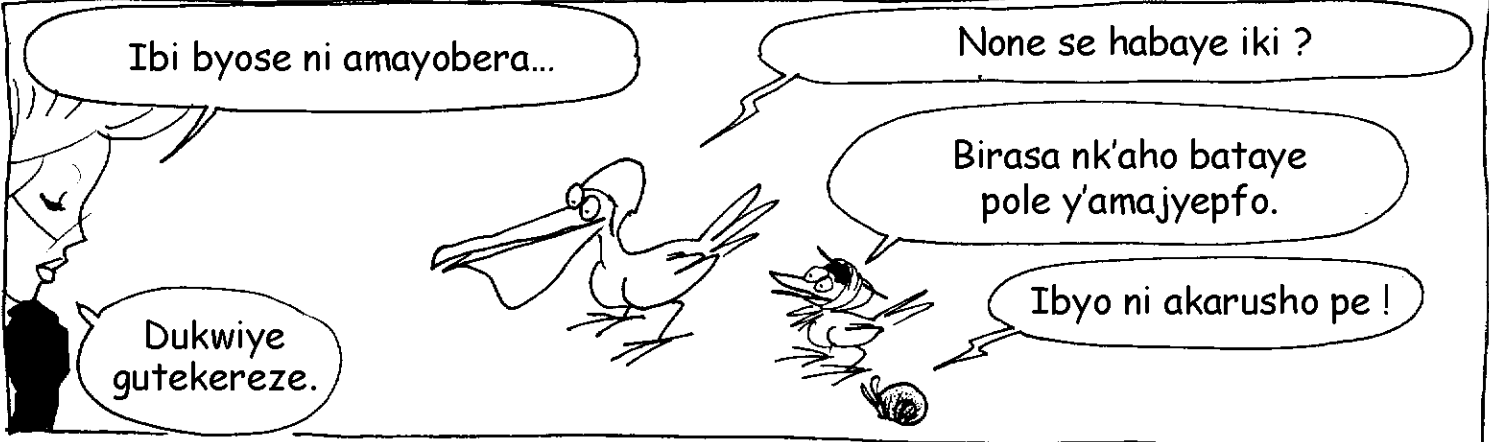

Ibi byose ni amayobera...

None se habaye iki ?

Birasa nk'aho bataye pole y'amajyepfo.

Ibyo ni akarusho pe !

Dukwiye gutekereze.

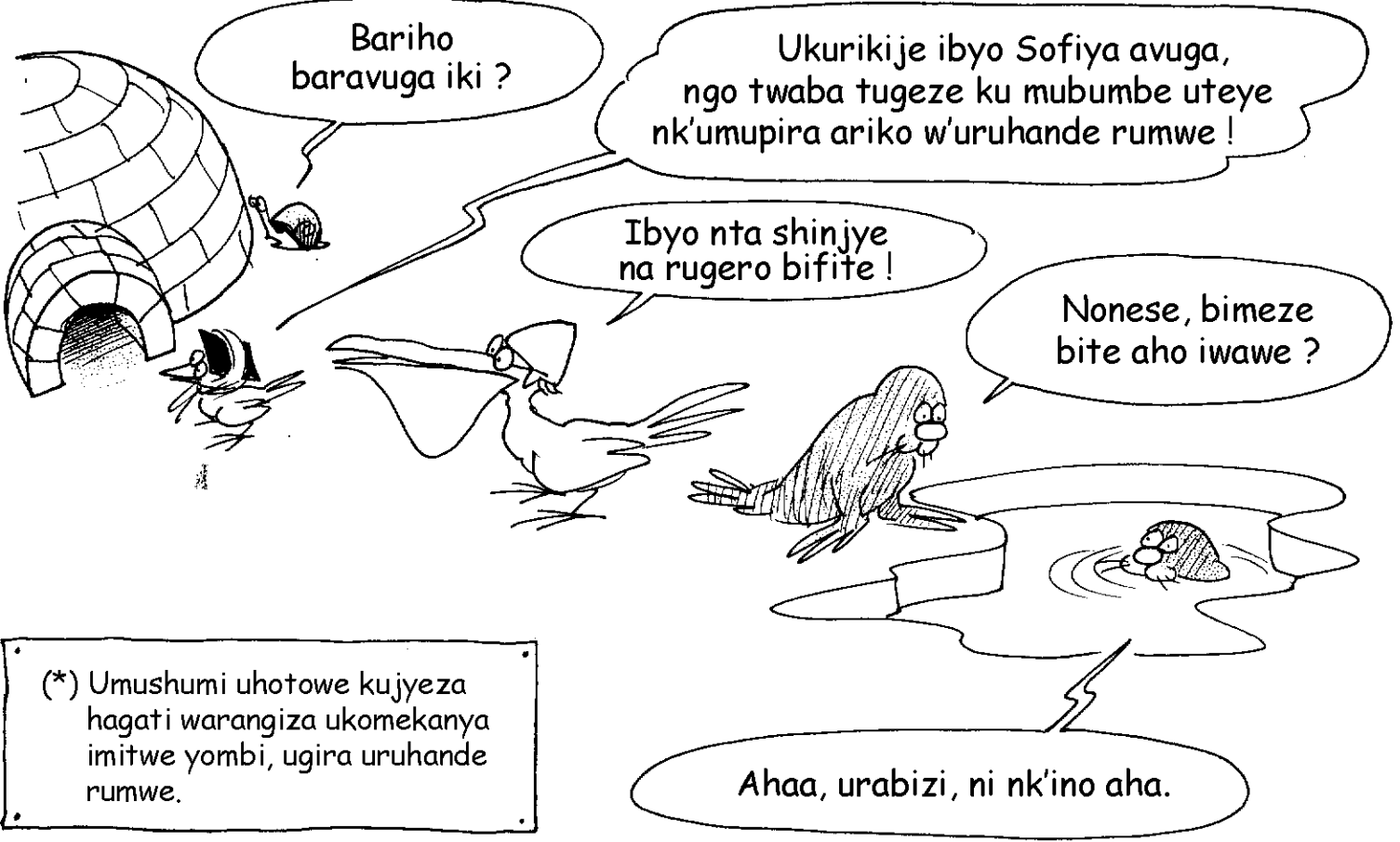

Bariho baravugaga iki ?

Ukurikiye ibyo Sofiya avuga, ngo twaba tugeze ku mubumbe uteye nk'umupira ariko w'uruhande rumwe !

Ibyo nta shinjye na rugero bifite !

Nonese, bimeze bite aho iwawe ?

(*) Umushumi uhotowe kujyeza hagati warangiza ukomekanya imitwe yombi, ugira uruhande rumwe.

Ahaa, urabizi, ni nk'ino aha.

Nimba dushaka gukura bwana Amundeseni muri buriya buzima bubabaje arimwo, tugomba mbere ya byose gusobanukirwa n'imiterere, n'iforoma y'iriya palanete idasanzwe. Tugerageze gukoresha amahame y'ibanze ya **TOPOLOJI**. Kubera ibyo tugiye guhambura ikintu icyaricyo cyose muri :

CELILE NYEGERANYI

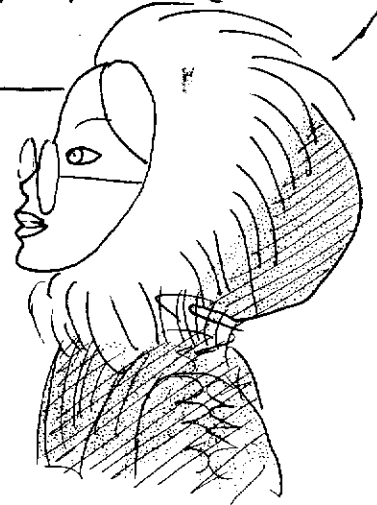

Ikintu kityeageranya ni akadomo...

Ariko se, akadomo twagakoresha iki?

Ikintu cyose kigereranwa n'itsinda ry'utudomo, kigira umwanya kicaramo. Kizitwa inyegeeranyo iyo gishobora kwiyegeranya muri iyo nzira kicayemwo, kuburyo kigaruka kikaba akadomo.

Urugero twafata ni kariya gace k'umurongo w'umuzingi. Ni **IKINTU CY'URUHANDE RUMWE RW'IKIRERE**.

Ah, yego. Aho akadomo runaka gahagaze kuri uriya murongo w'umuzingi hashobora gupimwa ukoresheje igipimo kimwe gusa : abusisi y'umuzingi, cyangwa uburebure bw'umugozi butandukanya ako kadomo n'akandi kafashwe nk'itangiriro.

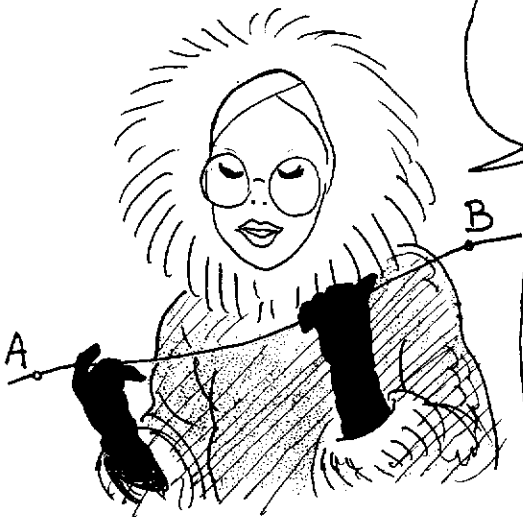

Nshobora gushyira icyo gice cy'umurongo w'umuzingi mu kintu kimeze nk'umuheha cyangwaitiyo ku buryo ako gace k'umurongo w'umuzingi uteretsemwo wakwiyegeranya, ugakomeza ukiyegeranya...

Nka merikire muri terimometero.

Ese mu by'ukuri, umurongo uwariwose ni nyegeranyi ?

Oya, imirongo y'imizingi ifunze ntabwo ari nyegeranyi.

Yego... ariko haba habuze kuwukata gusa !

Ariko rero, uwo **MUZINGI** uhinduka **UMURONGO**. Ntuba ugifunze.

Akarorero, iyo mfashe umuzenguruko. Nshobora kuwuhinahina ukaba nk'akadomo nk'uku ?

UMUZENGURUKO ntabwo rero ari **NYEGERANYI**, ni kimwe n'indi mizingi yose, yaba ari ishashe neza cyangwa iyihese mu kirere.

Oya, ibyo si byo kuko ntuba ukigarukamwo. Uca nyuma y'uburiri bwawo bwa mbere.

Ibiramambo, **IDISIKYE**, agace k'**UBUSO** ko ni nyegeranyi.

Iyo disikyeye ni agace k'ubuso,
ni ukuvugako ari ikintu k'impande
ebyiri. Ese ni ikihe kintu k'impande 2
kimeze kuri disikyeye nk'uko serikyere
imeze ku gace k'umurongo

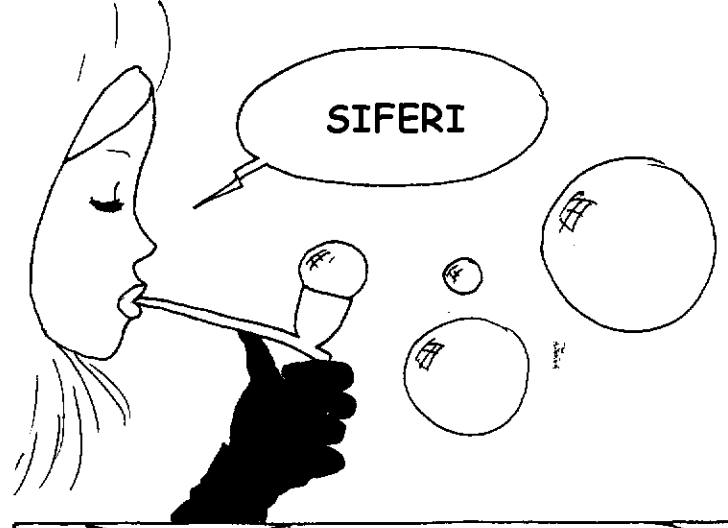
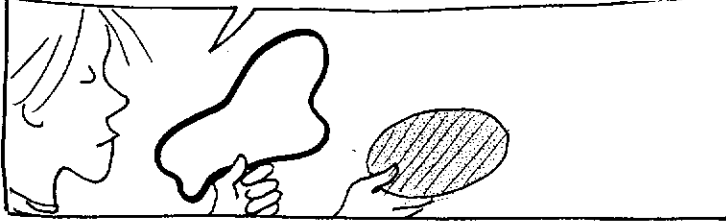

SIFERI

Kugirango wegeranye
umuzingi ufunze ugomba kuwukata.
Na siferi ni uko cyangwa ikindi kintu
cyose cyo mu BWOKO bwa siferi.



Urugero ni
igishishwa k'igi !



Ariko iriya siferi itoboye
ntiba ikiri iriya nyabuso
ifunze yitwa siferi

Nonese ni iki ?

Ni disikyeye se ?



Ni byo ryose Tireziyasi,
ni nk'uko serikyere ikase imera
nk'igice cy'umurongo.



Nonese SOFI,
VOLIME iri muri siferi, mw'igi,
ni nyegeranyi ?

Aho niho
hari ikibazo...

Urtyo. « siferi buso » S2 (*) ntabwo
ari nyegeranyi ariko « siferi volime » yo ni yo.

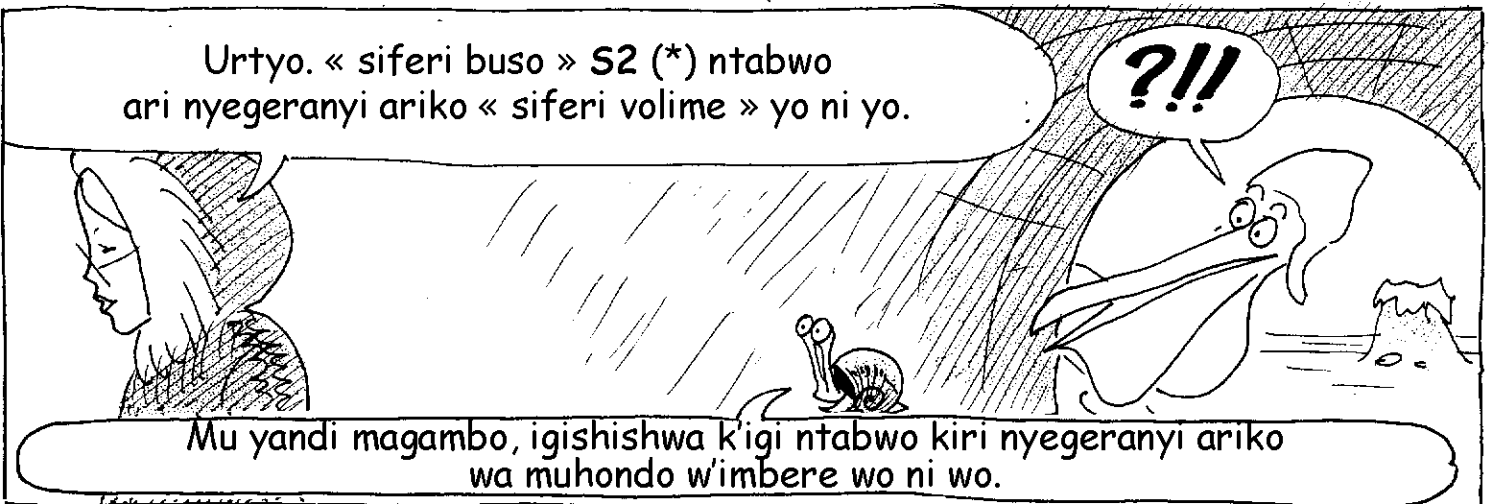

?!!

Mu yandi magambo, igishishwa k'igi ntabwo kiri nyegeranyi ariko
wa muhondo w'imbere wo ni wo.



Ese haba hariho
za volime zitari nyegeranyi ?

Yego pe, urugero ni
« ingata-mubumbe ».



Yego biragaragara. Naho ntayikata
nshobora kuyegeranya ikaba
nk'umuzingi wa serikyeri.



Ni ukuvugako n' « ingata-buso »
nayo itari nyegeranyi.

Mbwira,
mu by'ukuri uri
mu biki?

Kora
ibikureba, di.



Sinziko mubibona ariko
dufite umushakashatsi
w'umukerarugendo w'intagondwa
ku maboko yacu.



Mu by'ukuri
muratekereza ko tuzikura
hano kubera ko twakase
umutsima mwo kane gusa ?

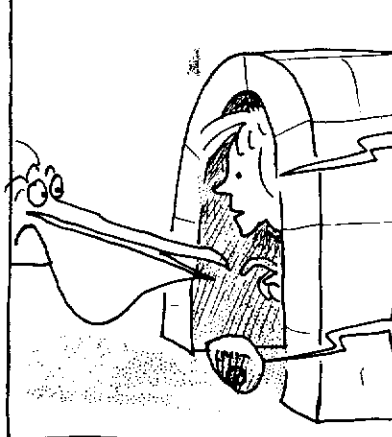

UBURAKARI NJYANABUTAKA bwe bufite
inkomoko muri jewometiri. Yenda tunonsoye ibitekerezo
nyubakiro niho twabona umuti uzamuvura.

Umubiri we wose urareze utegereje ivumburwa
rya pole y'amajyepfo, icyo gitekerezo yaracyihebeye
we ubwe no mu mibereho ye n'abandi.

Ubuyerezezi bwe
bwamushyize mu kibazo adashobora
gukyemura ubwe.

Yegooo, ukwibazaho
birebire bije ako kanya
kuri jyewe mu njyeri
zose ndende!

Muri make, umuti ushoboka
w'ikibazo ni ukumenya aho iriya
nyagwa ya pole y'amajyepfo
yarengeye.

ICIKAGURIKA MU MA SELILE

Ikintu cyose gifite imiterere ya jewometiri gicikamwo uduce twibanze, uduselile
mpfunyapfunya tw'ingero zose, nka : UTUDOMO, IBICE CY'UMURONGO,
IBICE CY'UBUSO, IBICE BY'UMUBUMBE,
n'ibindi n'ibindi...

Nonese,
AKADOMO gafite
impande zingaha ?

Twaguye imyumvire,
twavuga ko akadomo nta
ruhande kagira.

Mu bundi buryo, ushaka gushwanyaguza umuzingi,
uwufata nk'igice cy'umurongo imitwe ya cyo yahurijwe
mu kadomo. Urebye rero, nkuyemwo ako kadomo hasigara
igice cy'umurongo.

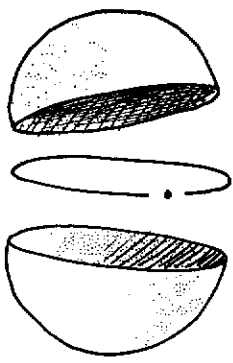

I « SIFERI BUSO » S2
ishobora gukatwamwo ingofero
ebyiri n'igice cy'umurongo
gifungiyeye ku kadomo.



I « NGATA MUBUMBE » ?
Turebe, nayishwanyaguza
nkoresheje
i disikye.

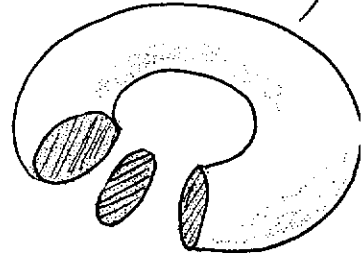

Naho i « NGATA-BUSO » ?
Turebe, nayikatisha i serikyere nayo
ubwayo ikatishijwe akadomo.

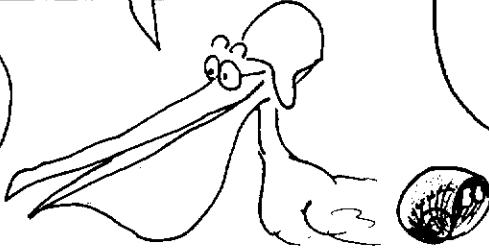
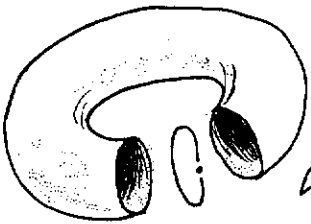

Iyo ngata yakaswe ihita
yiyegeranya ikurikije i serikyere:



Nayo kazashwanyuzwa ihita itanga
igice cy'umurongo n'akadomo.

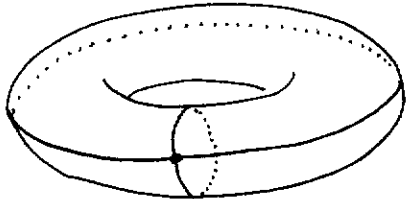

Dore ubundi buryo ukoresheje akadomo,
uduce tubiri tw'umurongo n'ubuso bumwe ariko
ibihimba byose bikaba ari nyegeranyi.

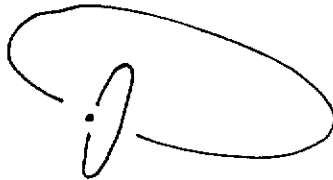
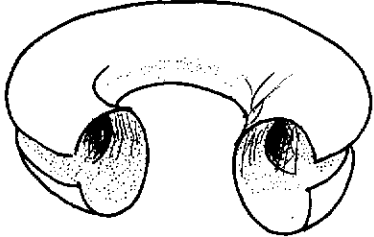

Yego, ariko se ibyo byose tuzabikoresha iki ?



Ku bigaragara bizadufasha
gusobanukirwa uko isi iteye.

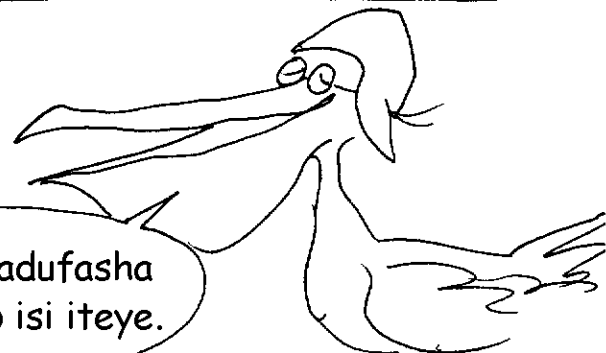

IKIMENYIMENYI CYA EWULERI-PUWANKARE

Ikintu cyose rero kigiye gishwanyaguzwa muri ubwo buryo, reka rero duhimba umubare χ ungana n'igiteranyo cy'umubare w'utudomo ukuyemwo umubare w'uduce tw'umurongo kongeraho umubare w'uduce tw'ubuso nyegeranyi, ugakuramwo umubare w'ibice by'imibumbe nyegeranyi (*), noneho uwo mubare tubonye χ tukawita **IKIMENYIMENYI CYA EWULERI-PUWANKARE**



Biryo rero serikyere yaba ifite $\chi = 1-1 = 0$



SIFERI BUSO yo yaba ifite $\chi = 1-1+2 = 2$



Akadomo kamwe, igice cy'umurongo kimwe, ingofero ebyiri

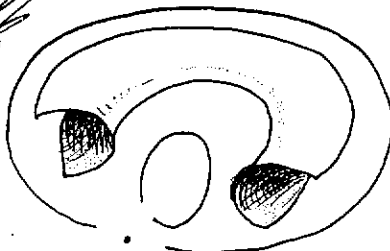
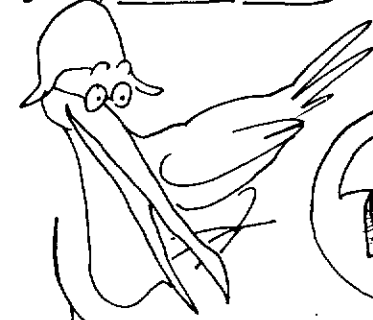
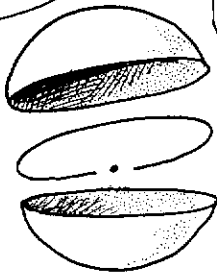

Reka turebe noneho **INGATA-BUSO**, ivamwo akadomo, uduce tubiri tw'umurongo, n'agace kamwe k'ubuso ; ubwo $\chi = 1-2+1 = 0$

Ni ukuvuga akadomo kamwe, ibice bibiri by'umurongo, igice kimwe cy'ubuso mpfunyapfunyi



IKIMENYIMENYI CYA SIFERI-MUBUMBE ni ibyumvikana ko ari -1, ariko iy'**INGATA-MUBUMBE** ari $1-1 = 0$ (reba igishushanyo

cyo hejuru n'iburyo bw'urupapuro rwa 14)

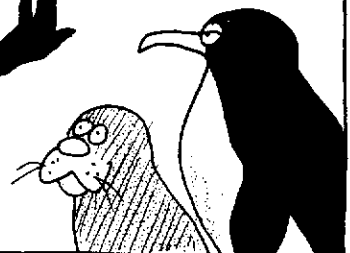
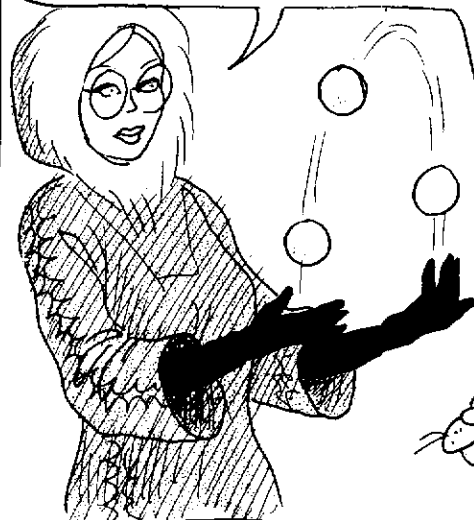

(*) Bihita byiramburira ako kanya k'umubare wa dimansiyo zisumbye eshatu (ni igiteranyo k'imibare igenda ihushanyije.)

Ubu rero, byumve neza : kiriya kimenyimenyi χ nti kigenwa na busa n'uburyo ukoresha mu gucagagura (mu duce mpfunyapfunyi) !!

Akarorero ni uyu murongo ufunze wakaswemwo ibice munani, bihujwe n'utudomo munani ariko kandi ikimenyimenyi cya wo kikaguma ari ubusa.

Ni byo pe.

Turebe iri shwanyuzwa rya siferi : amasonga 4, ibice by'umurongo 6, impande 4, bikampa $\chi = 4 - 6 + 4 = 2$

Hariya naho, amasonga 8, ibice by'umurongo 12, impande 6, bigatanga $\chi = 8 - 12 + 6 = 2$

Ushobora kugerageza uburyo bwose ushaka, uzasanga aha $\chi = 2$

Mbega mbega !

Ntibitangaje, se ?

Dore teworeme y'ingirakamaro : niba ikintu kigizwe n'iteranywa ry'ibintu bibiri, ikimenyimenyi cya cyo kingana n'igiteranyo k'izibyo bintu bibiri bikigize.

Ubuyobozi



I Ngata-Mubumbe ifite ikimenyimenyi kingana n'ubusa.



Iyo twongeyeho umukondo-mubumbe tuba twongeyeho rimwe ku kimenyimenyi cya cyo.

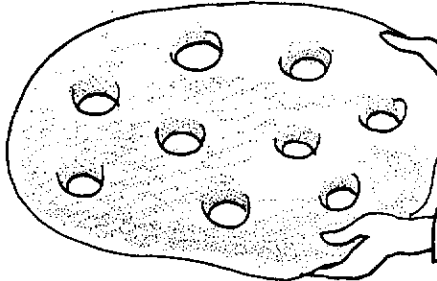

Muri icyo ntumbero y'ibitekerezo, tubonako FUGASE-MUBUMBE (*) igomba kuba ifite ikimenyimenyi kingana n'umubare w'imyobo ifite gukuramwo rimwe.

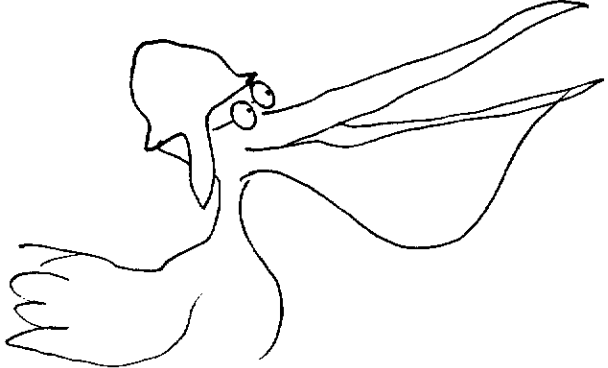

Biryo se byaba ari bimwe no kubiyanze na FUGASE-BUSO ?

(*) ubwoko bw'umukati wo mu majepfo y'u Bufaransa.

Ntaho bihuriye! Nyabuneka, FUGASE-BUSO
ntishobora kwipfunyapfunya ikurikiye disikyeye y'intoboro N!

Nsa nucanganikiwe...

Ushobora gukora
INGATA-BUSO (ikimenyimenyi 2) ufashe INGATA-BUSO
(ikimenyimenyi ubusa) ukayongeraho umukondo-buso.
Birtyo konjyeraho umukondo-buso bigabanya ikimenyimenyi
cy'ubuso ho 2.

Birtyo, ikimenyimenyi cya FUGASE-BUSO
kingana na 2 gukuramwo umubare w'intoboro ifite !

Ubuso bw'igice foromaje
ya Guruyeri gifite intoboro
N kigizwe na Siferi-Buso
N hamwe na siferi y'inyuma.
Birtyo ikimenyimenyi
cya cyo ni $\chi = 2(1+N)$

Ariko gukora GURUYERI-MUBUMBE, utangirira kuri siferi-mubumbe
yuzuye ($\chi = -1$) noneho ukanoboramwo amatsinda N, buri imwe igizwe na
SIFERI-MUBUMBE + SIFERI-BUSO ($\chi = 2-1$). Birtyo, ikimenyimenyi
cya GURUYERI-MUBUMBE kingana na $-(1+N)$

Uremerako koko
uzashobora gukiza uriya
muteragahinda Amundeseni
uburakari nyabutaka bwe ?!!

iyi Si TUBAMWO

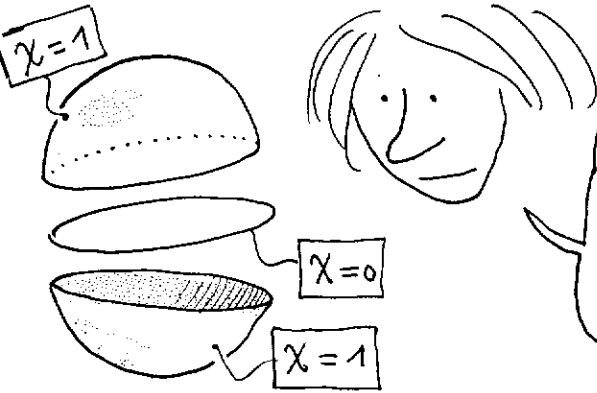

Dushobora kugera ku kimenyimenyi cya siferi S2 tuyifashe nk'itsinda rigizwe na emisiferi ebyiri hamwe na ekwateri imwe, ibyo bikatugeza ku mubare wa $\chi = 1+1+0 = 2$

Mu gitabo cya **JEWOMETIRIKONI**, twerekanye igitekerezo-mfatiro cya **IPERISEFERI S3**, ya dimansiyo eshatu, nka esipase mpandeshatu **YIFUNGIYEHO** hose.

Tugiye gushaka tubara ikimenyimenyi cy'iyi iperisiferi **S3**. Nk'uko twabibonye mu gitabo cya **JEWOMETIRIKONI**, ekwateri (*) nisiferi **S2** y'ikimenyimenyi kingana na 2.



Iperisiferi **S3** yacu rero igizwe n'imibumbe ibiri nyegeranyi, umwe wose ufite ikimenyimenyi cya -1.

Yee, ubwo nti muri ibigoryi ?

$$\chi = -1-1+2 = 0$$

SNAPU!

(*) Igabanya ikintu mwo ibice bibiri bisa.

Birtyo rero, ikimenyimenyi cya iperisiferi **S3** kingana n'ubusa !

Tujye kuri iperisiferi **S4**,
y'impane ennye.



Ni ukuvuga ikirere giteye nka
iperisiferi **S3** igira urugendo buri
gihe isubiramwo (*). Iyo iperisiferi **S4**
ekwatori yayo izaba ari iperisiferi **S3**,
kandi za emisiferi ebyiri zizaba zo
zibara imwimwe ikimenyimeyi cya 1.

Ni ukuvugako ikimenyimenyi x cy'iyoy
esipase-gihe, cy'iyoy iperisiferi **S4**,
kizaba kandi kingana na $1+1+0 = 2$

Ufashe iperisiferi **S5**
ya dimansiyo eshanu, ikimenyimenyi
cya yo cyaba kandi ubusa kandi
ekwatori yayo yaba ari
iperisiferi **S4**.

Dukomeje durtyo...
ikimenyimenyi cya
Ewuleri-Puwenkare cya
iperisiferi **SN** cyaba 2 iyo
N igabanyika na kabiri, ubundi
kikaba 0 iyo **N** ari igiharwe.

Nyabuneka, nibikomeza birtyo,
jye ndahita nkora nka Amundeseni.

(*) Reba **BIGI BANGE** na modeli za **FIRIDIMANI** kuri page 64.

Rwose, iki kimenyimenyi
cya Ewuleri-Puwankare cyatumye
dushobora gushyira ku murongo
muri iriya nzitane y'ibintu biteye
bwa jewometiri.



Birtyo, kiriya gice cya silenderi gisa
mu buryo bwa topoloji nk'idiskye ifite intoboro imwe,
birtyo rero ikimenyimenyi cya yo kikaba ubusa.



Ariko se kiriya kintu
ugitekerezaho iki ?

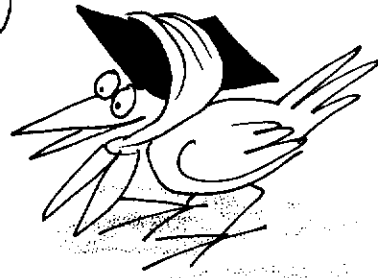

Ni **URUGORI RWA MOBIYUSI**,
rufite uruhande rumwe gusa. Nk'uko nta waruha
IMBERE cyangwa **INYUMA**, tuvuga yuko
ari **URUTAGANISHWA**.

Mu by'ukuri, ingori zose zifite umubare
UGABANYIKA NA KABIRI w'IBICE BY'UMUSINGI
ni ingori za **MOBIYUSI, ZITAGANISHWA**.
Ariko izo ngori ebyiri urebye neza ntizisa...

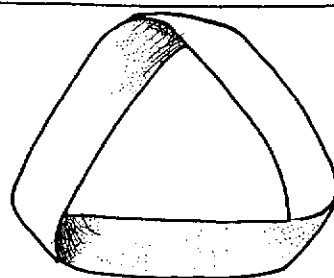
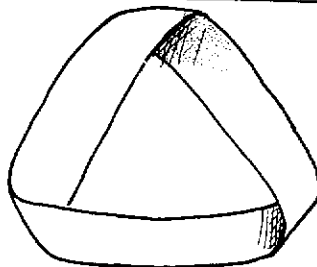

Uko nagira kose, nzihindukiza,
nzerekeza mu mpande zose,
sinshobora kuzihindura ngo zise,
zibe zimwe neza.

Ntabwo zihotowe ziganishwa mu
CYEREKEZO kimwe. Mu by'ukuri,
rumwe ni ishusho y'urundi mu
ndorerwamu ; ubwo rero zitwa
ENANSIYOMORUFIKE.

Neza zimeze nk'uko ikiganza k'ibumoso giteye
nk'ishusho yo mu ndorerwamu y'ikiganza cy'iburyo.

Izo ngori zose, zishobora kwipfunyapfunya
zikurikiye umurongo ufunze, zifite
ikimenyimenyi kingana na 0.

Yego pe, hariho
IBINYABIRERE BITAGANISHWA
bya dimansiyo N (*)

URUGORI RYA MOBIYASI ni ubuso
BUTAGANISHWA, bufite **URUHANDE**. Ese habaho
INYABUSO ITAGANISHWA, **ITAGIRA URUHANDE**,
YIFUNGIYE KURI YO YONYINE ?

Igisubizo kiri muri shapitiri ikurikira

UMUSOZO KU MUSOZO

UMUZINGI UFUNZE (uvanwamwo igice cy'umurongo n'akadomo) ufite ikimenyimenyi kingana n'ubusa. Ni kimwe n'IGITAMBARO, cy'impande ebyiri cyangwa rumwe, gishobora kwipfunyapfunya gikurikije umurongo ufunze (reba teworeme urupapuro 17). Ufunze igitambaro cy'impande ebyiri na disikye ebyiri, ukurikije imirongo ibiri ifunze, usanga wakoze SIFERI-BUSO S2 (ya dimansiyo ebyiri)

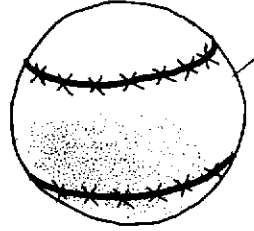
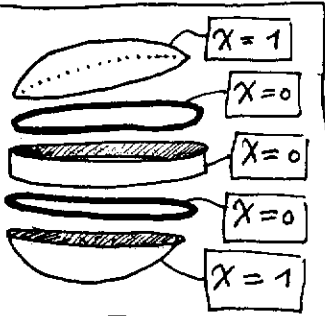

Ushobora kandi gufatanya ibitambaro bibiri by'impande ebyiri, kimwe ukidodeye ku kindi ukurikije imirongo ibiri ifunze, birtyo ugahita ubona ko wakoze i NGATA-BUSO T2.

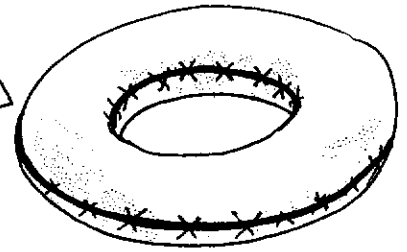
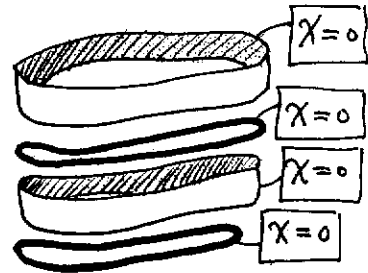

Ubwambere na mbere ngomba gufatanya ingori ebyiri za Mobiyusi nkurikije UMURONGO UMWE UFUNZE.

Ye !?!
birancanze.

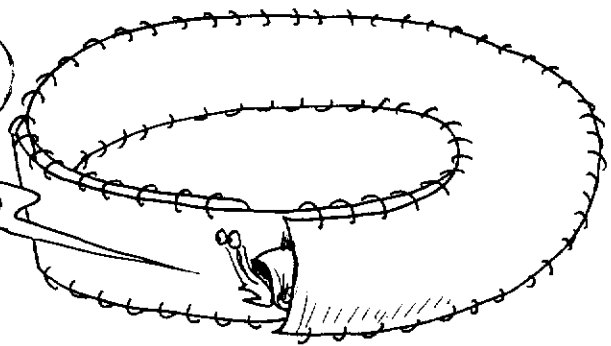

Ba uretse,
ni ukugomba gukoresha
TARAVERISINE (*)

TARAVERISINE !?



(*) TARAVERISINE ivanwa mu bimene by'amagi ya HOMOTOPE.

Iyo usize **TARAVERISINE** ku kimene k'igi,
gihita gikururuka gikurikiye **umusozo** wacyo, gishaka gukora igice
cy'ubuso gifunze, ariko kandi kigaha ubwo buso,
ububasha bwo **KWINYURAMWO** !

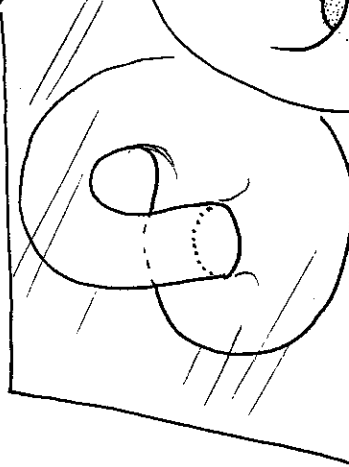
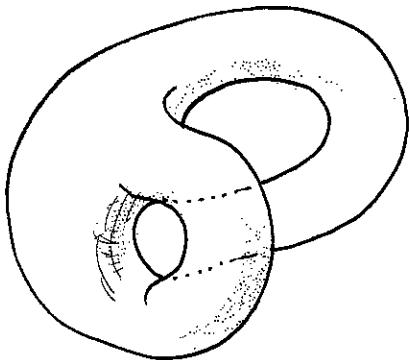
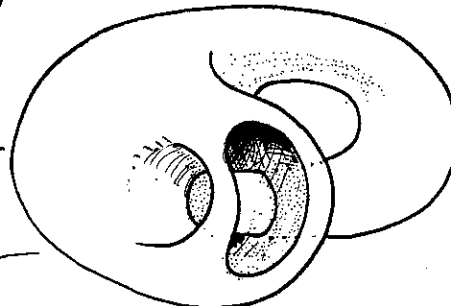
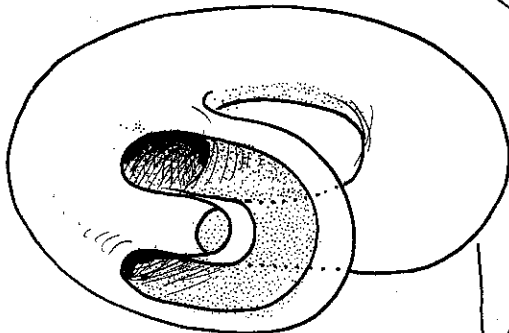
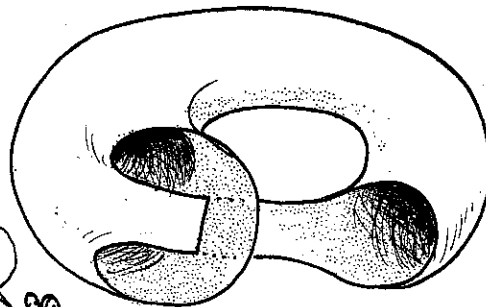
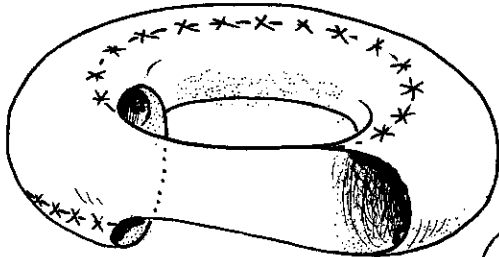

Wa musozo
warigise. Ariko se,
uwo muzenguruko
ni nyabaki ?

Ni **UMUZINGI W'IHURIRO**, utari umusozo.
Ushobora gusuzuma neza ko muri iri **CUPA RYA
KELEYINI** ubuso bugendera ku intera
imatanye kimwe hose.

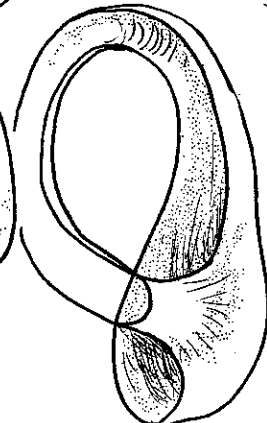
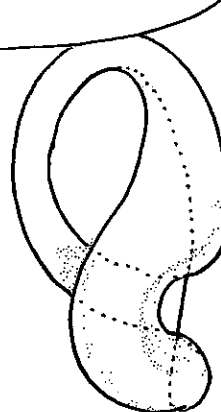
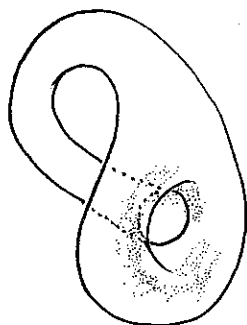

Ibimanyu
bya kabiri
bibiri

Ikimenyimenyi cya ryo kingana n'ubusa rikozwe n'ingori ebyiri za Mobiyusi ($\chi = 0$) n'umurongo umwe ufunze ($\chi = 0$). Ntawe bitorohera guhita abona rumwe muri izo ngori.

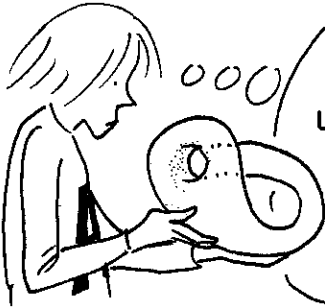
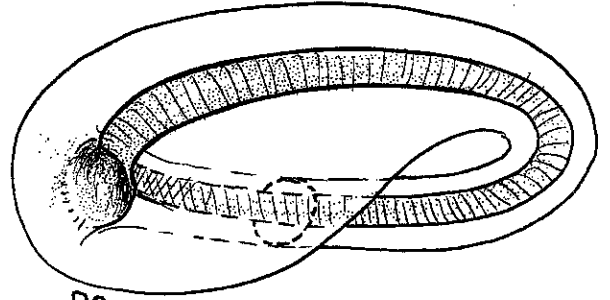

Biryo pe, iyo ubonye urugori rwa Mobiyusi ku nyabuso, ni ukuvuga ko iyo nyabuso iba ifite uruhande rumwe.

Ahubwo se Tireziasi, nti twabona urugori rwa Mobiyusi kuri icyo gishishwa cy'igi cya we ?

Aha, mwe uko muri babiri nti mwongere !

Era.. !

Ariko ubundi, ni iki ni ubwoko bw'inyabuso yihariye...

Kugeza ubu, ubuso butinyuramwo, nka SIFERI, cyangwa INGATA, mw'iforoma yabwo isanzwe. Inyabuso zinyuramwo mu kirere cyacu bazita **IBYIHINGUKEMWO**.

Ama...ibyhingukemwo ?

UBUKWEDUKYE N'IBYIHINGUKEMWO

Umuzingi ufunze, ni ikiremwa cya jewometiri y'uruhande rumwe, kizira impanuka z'urugendo kandi w'uburanga bumwe bwo kutagira ari itangiriro, ari ni iherezo. Birtyo rero rwose, hariho uburyo bwinshi bw'intabarika bwo kuwutereka muri ikibyatarare.



Iyo utinyuramwo, uba **WIKWEDURA MU KIBYATARARE** naho ubundi, navugako uba **WIHINGUTSEMWO (*)**

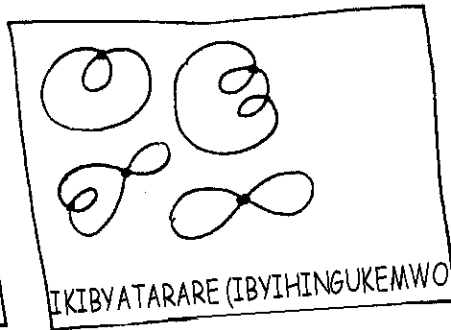
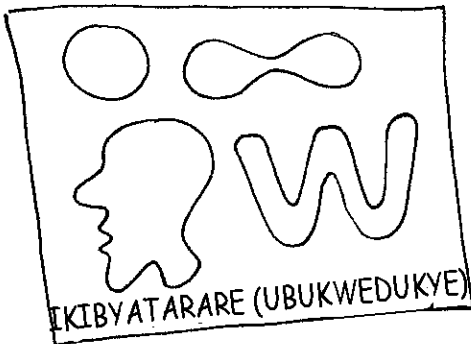

Ndatekereza ko birangwa n'umubare w'utudomo tw'innyuramwo

Oya, kuko iyo nkomeje nkwedura iyi mizingi, nshobora kuzana cyangwa kurigisa ama **TSINDA Y'UTUDOMO TUBIRI TUBIRI**. Ariko ikitazahinduka ni **UMUBARE W'INSHURO Z'UBUZENGURUKE**.

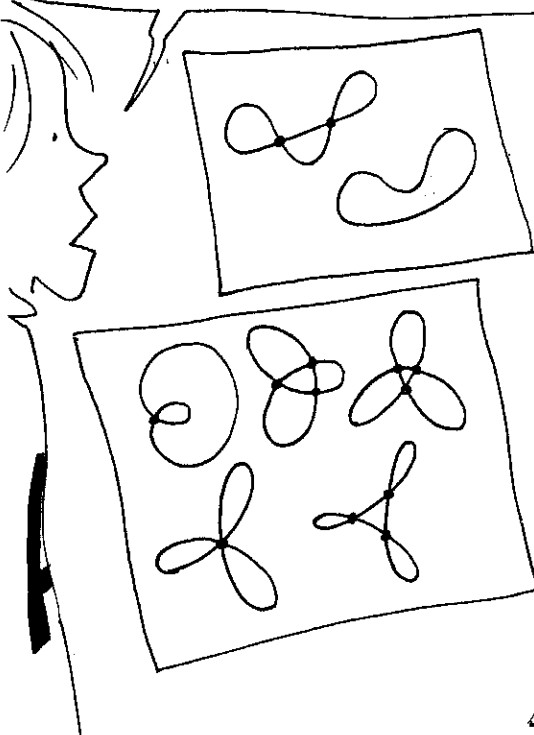

Reba, nkora k'uburyo i vegiteri ikomeza yitseta ku muzingi ku kadomo kamwe.

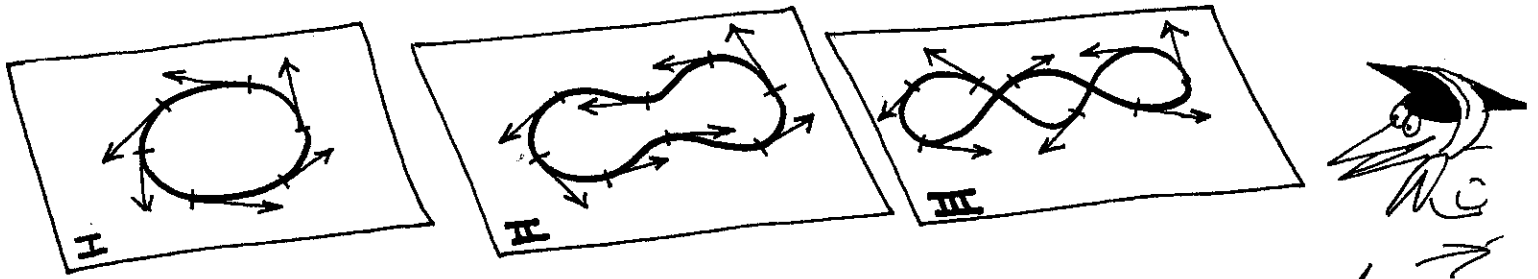

Ukoresheje ubukwedukye busanzwe (nta mirongo ivunitse), mu **KIBYATARARE**, nshobora kuva ku musingi **I** nkajya ku musingi **III**. Ibyo iyo bikorwa, ubuhindukire bwose bw'umwambi (360°) ntibuhinduka igihe cyo kunanara buri musingi.

Iki ni **HOMOTOPIYA IBONEYE** ikorerwa mu **KIBYATARARE**. Igumana wa mubare w'inshuro z'ubuzenguruke bw'umwambi witseta ku musingi.

Nakoresheje uburyo bwose ariko nananiwe guhindura uyu **MUNANI** mu **MUZENGURUKO**.



Ni ibisanzwe. Umwambi ntukora inshuro z'ubuzenguruke zimwe. Ku **UMUNANI**, igiteranyo aligeburikye cy'ubuzenguruke kingana n'ubusa.



Ufatiye kuri iryo tegeko ry'ubukwedge bw'imizingi ifunze (ubukomereze, ububonere), mu kinyabuso, hariho ibintu **BISHOBOKA** n'ibindi **BIDASHOBOKA** igihe cyose.

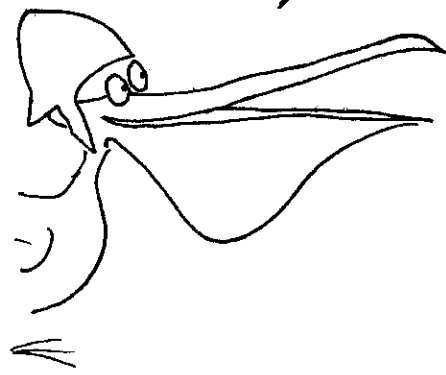

Ntibyoroshe !

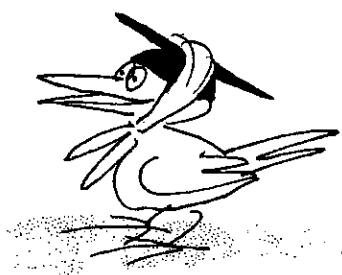

Biterwa n'IKIRERE
 icyo kintu gishushanyijemwo.
 Dore, urugero, reba uyu muzingi.
 Kuri iki kibyatarare, nta buryo
 bwo kurigisa utu tudomo
 tubiri twa dubure.

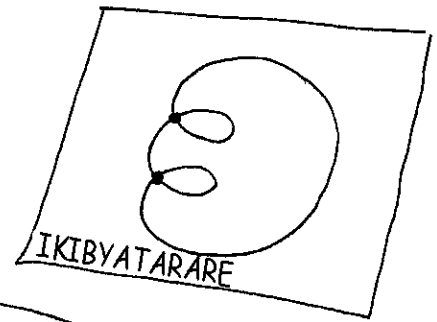

Ariko kandi,
 kuri SIFERI :

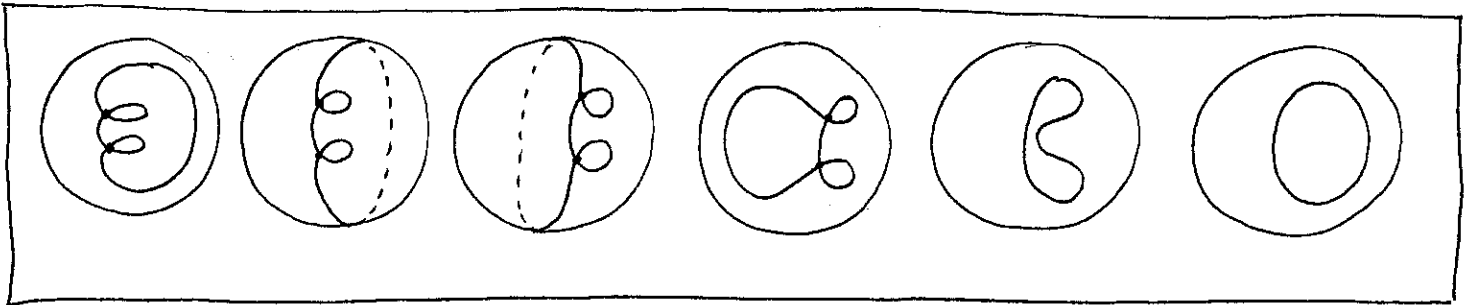

Biryo ibintu bimwe bigaragara nkaho bidashoboka
 mu KIRERE CY'UBUSERUTSI naka (aha ikibyatarare) biza gushoboka
 uhinduye icyo kirere, ugakorera mu kindi gifite topoloji inyuranye.
 Ubundi naho uhinduye n'ibindi birahinduka.

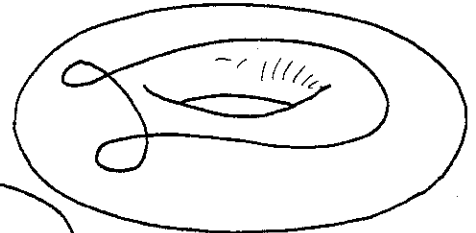

Mu kibyatarare, uyu muzingi urabohoka mu
 buryo bworoshye, ariko ntushobora kubikora
 iyo wawushushanyije ku ngata-buso

Ariko se rwose, Tireziyasi,
 muri ESIPASE-GIHE yacu, hariho ibintu
 BISHOBOKA cyangwa BIDASHOBOKA
 mu buryo budasubirwaho? Oya?

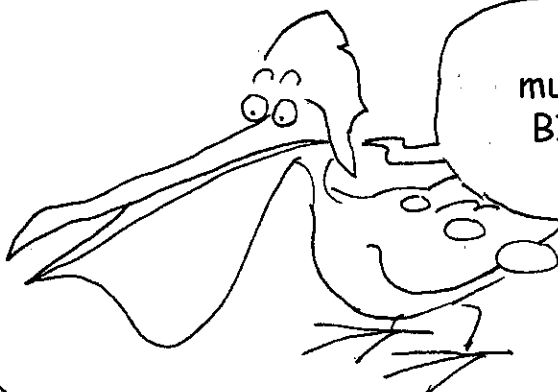

Agahinda...

Ese waba uzi, wowe, topoloji ya esipase-gihe yacu?

Eeeh...oya...

Tubayeho mu byigaragaza gusa... ariko kandi !

Utudomo huriro tw'umuzingi ufunze duterwa n'uburyo bwo kwerekana ibintu mu buso. Ishusho ya dimansiyo ebyiri ni igicapo gitumberejwe gusa ku kibwatarare.

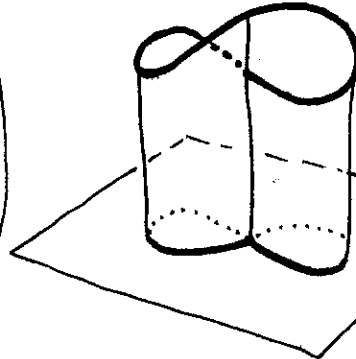

Muri ibi byose hari mu by'ukuri ikintu kimwe gusa : **UMUZINGI UFUNZE, IKIREMWA CYA DIMANSIYO IMWE**

Muri esipase nyerekerwamwo ya dimansiyo 4, icupa rya **KELEYINI** ntiryinyuramwo !

Ariko rero, iyo duhinduye esipase nyerekerwamwo, **BYOSE** nshobora kubikora. Nk'akarorero, icupa rya Keleyini rishobora guhindukamwo siferi ?

Oya, hariho ibimenyimenyi **BIDAHINDUKANA** na **ESIPASE NYEREKERWAMWO**.

TOPOLOJI

Akarorero : ikimenyimenyi cya Ewuleri-Puwenkare, icyerekeranyi, ubufunjye.

Ku bintu bya dimansiyo imwe, byose byasobanurwa birya :
UMUZINGI UGOMBA KUBA UFUNGUYE CYANGWA UFUNZE.



None se, Amundeseni ameze ate ?

Nta kuntu, nubu ni nka kwakundi...

UBURAKARI NYABUTAKA ?
Jyewe ahubwo nkyekako byaba
UBURAKARI NYAMITERERE.



Imiterere y'imyumvire y'ubwonko bwacu,
IMITEKEREREZE yacu, uko tubona isi, bishingiye ku ndiba za jewometiri,
zishobora gusaduka igihe icyaricyo cyose.

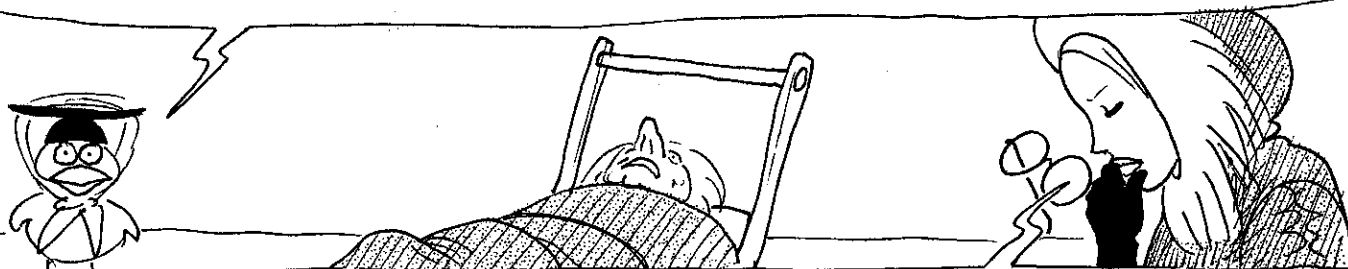

Nitudashobora kugarura imiterere nyayo na mikye mu mirebere mugenzi wacu afite y'ibintu bimwe na bimwe, hariho impungenge ko yakomeza gutsimbatarara yanga iyi si dukabakaba.

KUBOHA

Nashoboye kubona ubundi burtyo bwo kwerekana ubuso : KUBOHA

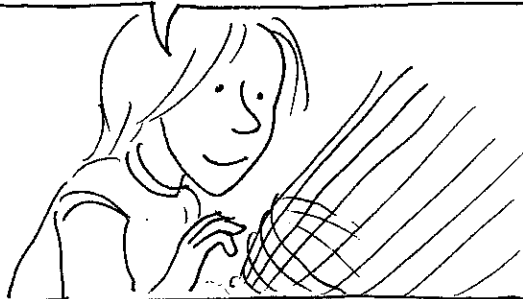

Akarorero, iki ni silenderi

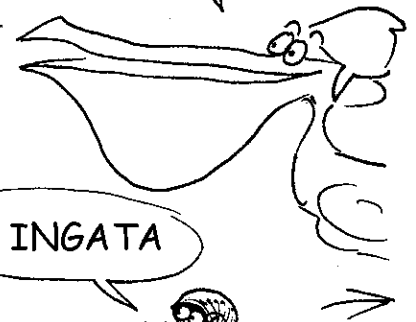
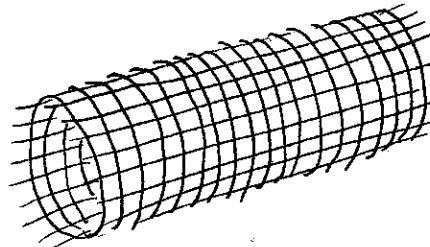

Ni INGATA

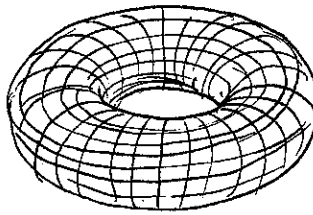

Mfite ibibazo kubijyanye na siferi

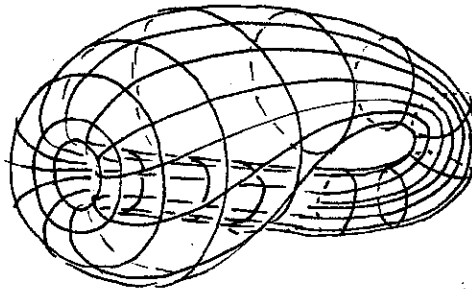

ICUPA RYA KELEYINI

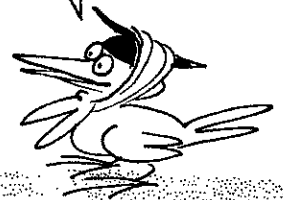

Ku bijyanye na SIFERI, ugomba gushyiramo POLE 2

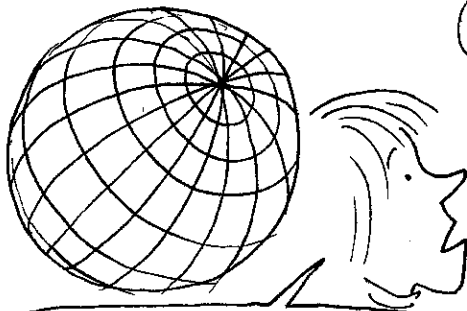

Ariko...simbyumva. Kubijyanye n'INGATA cyangwa icupa rya KELEYINI, sinzikeneye...

Ikimenyimenyi cya Ewuleri-Puwenkare kiguha umubare wa POLE zikenewe kugirango UBOHE ubuso bwawe. Ku bijyanye n'INGATA cyangwa icupa rya KELEYINI, ni zero. Ariko kubijyanye na siferi ni 2.



Iyo myumvire ishobora gukoreshwa,
neza rwose, kuri za **IPERIBUSO**
za dimansiyo 3,4,...., N

Usibye akabazo kandi, iniveri,
ukurikiye umudeli uhora ugaruka wa
FIRIYEDEMANI (*), ni iperisiferi **S4**.
Ndabyumva ko **ushobora** gutaka esipase
nyabutatu yose n'udutafari tw'iforoma
ya kibe. Ariko se wabigenza ute kuri
esipase ya dimansiyo ennye ?

Biroroshye, utaka hose
ukoresheje za **IPERIKIBE**.



Iperikibe ?
by'ukuri...

Ariko, ba uretse turebe...
ikimenyimenyi cya iperisiferi **S4** ni **2**.
Byumvikane ko esipase-gihe yacu
yakagombye kugaragaza byibuze
ubwoko bw'akanyamwihariko, pole ?



Naho se
BIGI BANGE (*),
ni iki !?!

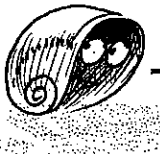

Bityo, ishingiyeye gusa kuri
jewometiri yaba yarashoboye guteganya
imwe mu buranga bw'amateka ya Iniveri
atangaje yavumbuwe mu gihe kimwe
na fenomene yo gukweduka
kwa Iniveri.



(*) reba **BIGI BANGE** (Icapiro **BELINI**).

IBINYAMWIHARIKO

URWEGO RW'IKINYAMWIHARIKO CYO KUBOHA

kingana n'imfuruka ifite umwambi uzenguruka mu ntumbero ya pozitifu cyangwa ya negatifu, ugabanije na dogere $360^\circ (2\pi)$

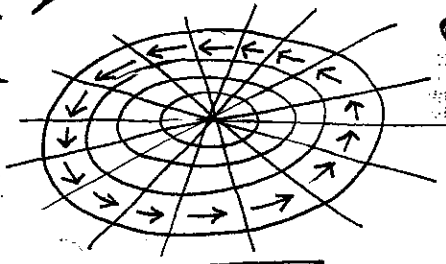

I POLE, ni 1

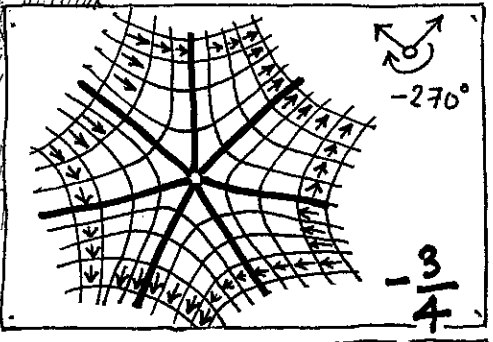
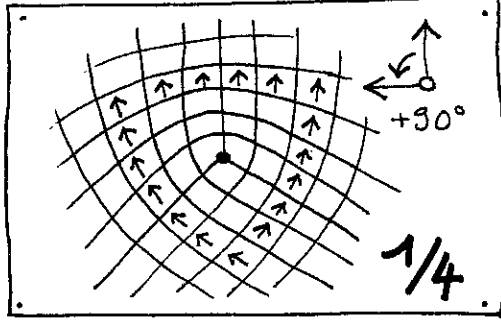
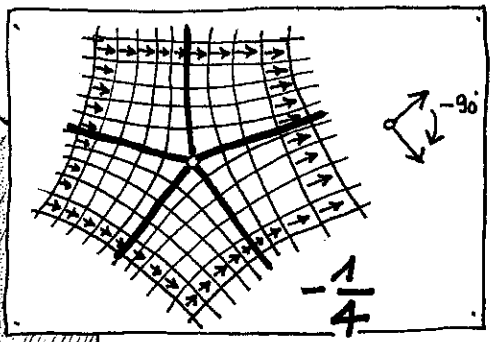
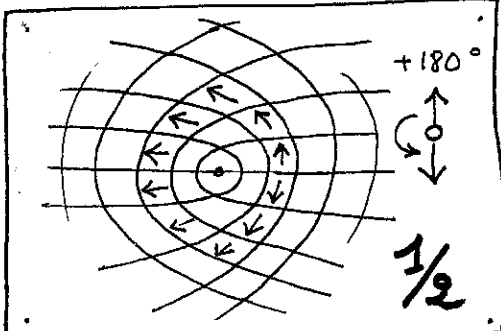

Dore ibinyamwihariko by'urwego rwa pozitifu (I bumoso) ni ibya negatifu (I buryo)

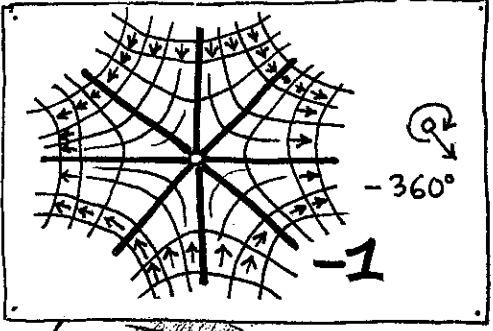
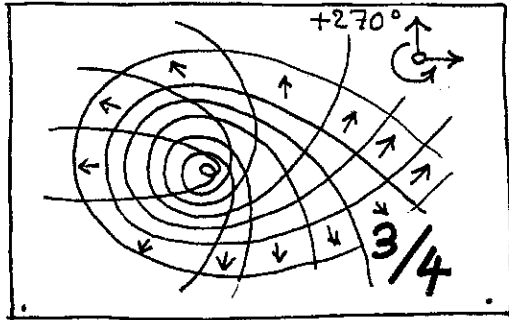

Inyungu ni iyihe ?

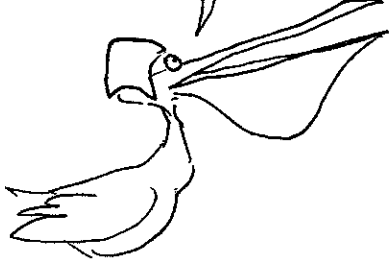

Utatse inyabuso ifunze, ugera kenshi ku binyamwihariko. Birtyo rero ikimenyimenyi cya Ewuleri-Puwenkare kizangana n'igiteranyo ali jeburikye k'inzego z'ibinyamwihariko.

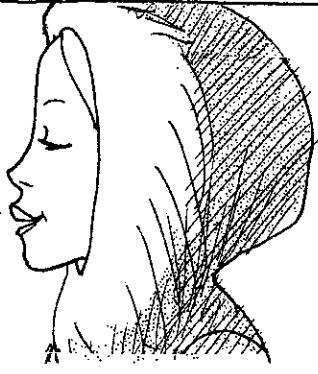
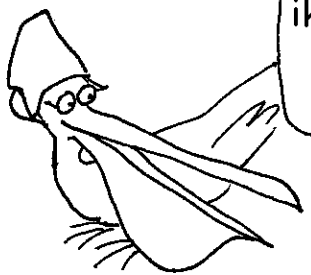

Nshobora gutaka **INGATA** nta kinyamwihariko. Ni ibisanzwe : ikimenyimenyi cya Ewuleri-Puwenkare cyayo kingana n'ubusa.

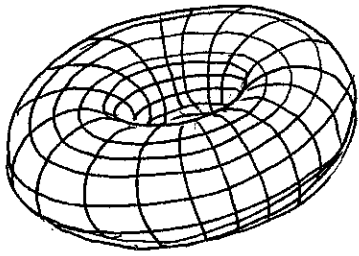

Naho reba siferi itatse ukoresheje ibinyamwihariko munani by'urwego rwa $\frac{1}{4}$...

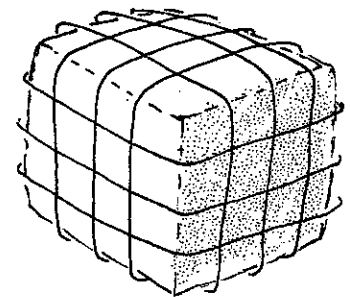
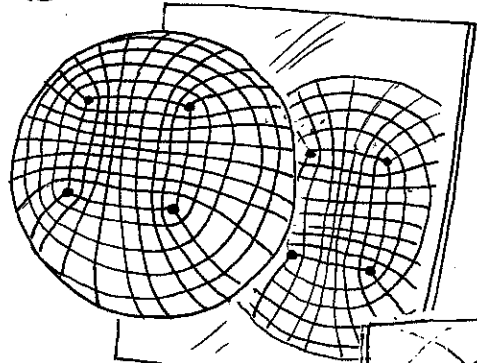

Cyangwa n'ikinyamwihariko cya kimwe cy'urwego rwa $\frac{3}{4}$ na $\frac{1}{4}$ na **POLE** imwe...

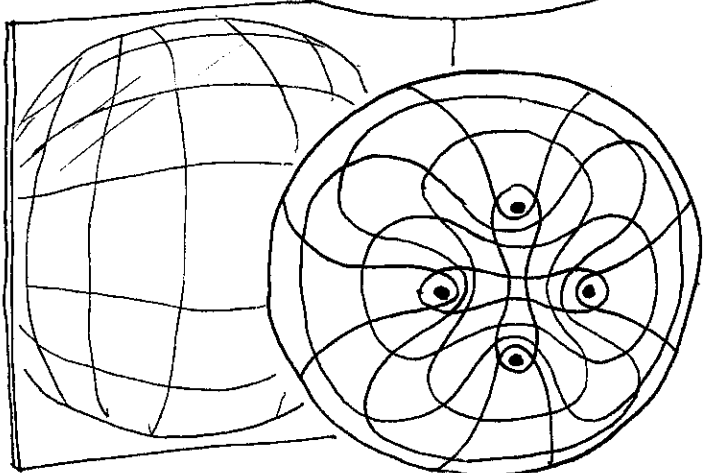
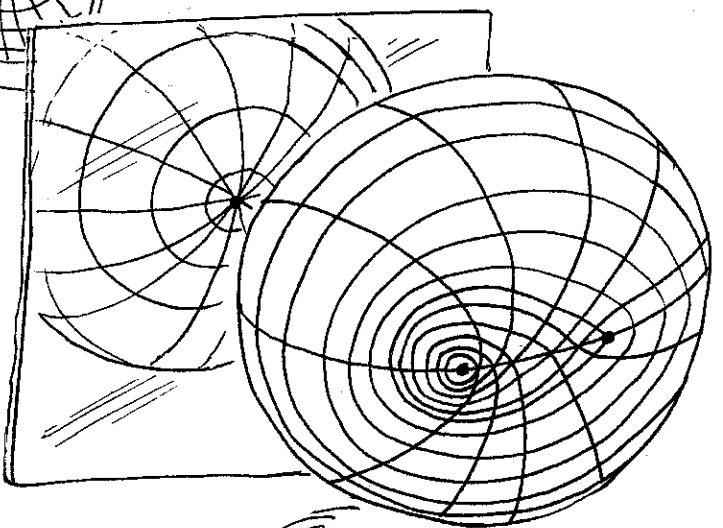

Cyangwa ukoresheje ibinyamwihariko bine by'urwego rwa $\frac{1}{2}$.

Uramenye :

Umusomyi uzaba yarasomye **UMWOBO W'UMUKARA** (icapiro **BELINI**), ipaje 14 kugeza kuri 36 azaba, ntagushidikanya, yarabonye imiterere imwe hagati y'ibishushanyo by'ibinyamwihariko by'ubutatsi n'ibiganisha, muri iki gitabo kuri za, **POZIKONE**, **NEGAKONE** n'ubuzingye. Ibi byigwa byose, bishingiye nka byose ku mfuruka, birafatanye cyane. **UBUZINGYE BYOSE** bw'inyabuso, bwerekaniwe muri esipase yacu ya dimansiyo eshatu, bungana neza n'ikimenyimenyi cya Ewuleri-Puwenkare, ukubye na dogere 360° (cyangwa na 2π).

Ubuyobozi.

Ibyago ni uko ibintu nk'ibi nta kintu na kimwe bimara,
ni nk'ikigirikiy cyangwa ikilatini.

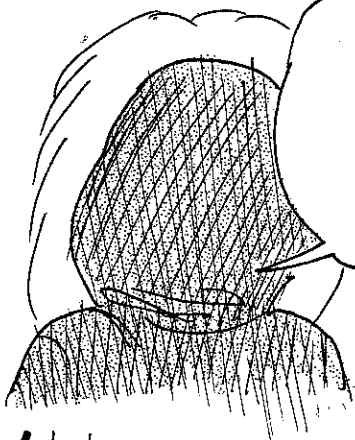
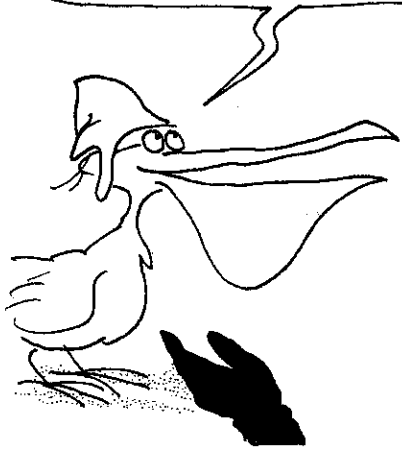

Oya pe, Lewo !
ibinyamwihariko,
ni byinshi cyane
muri natiri !

Ariko se hehe ?

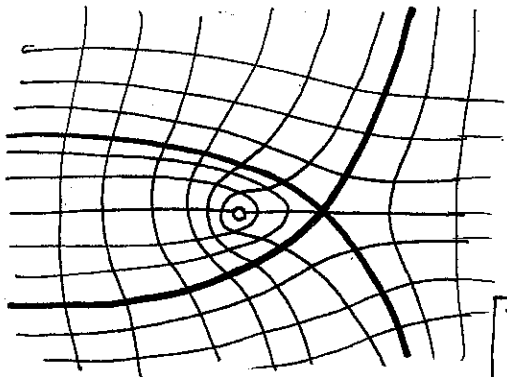
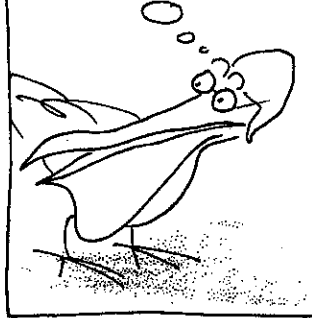

$$\left(\frac{1}{2}; -\frac{1}{2}\right)$$

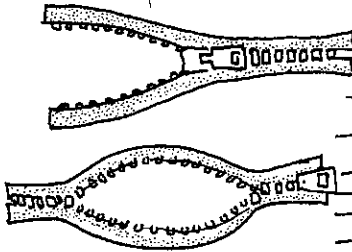

Kocora ubufungire
bwihuse

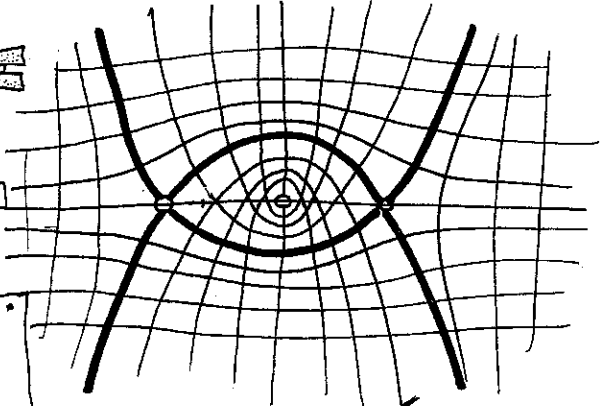

$$\left(-\frac{1}{4}; \frac{1}{2}; -\frac{1}{4}\right)$$

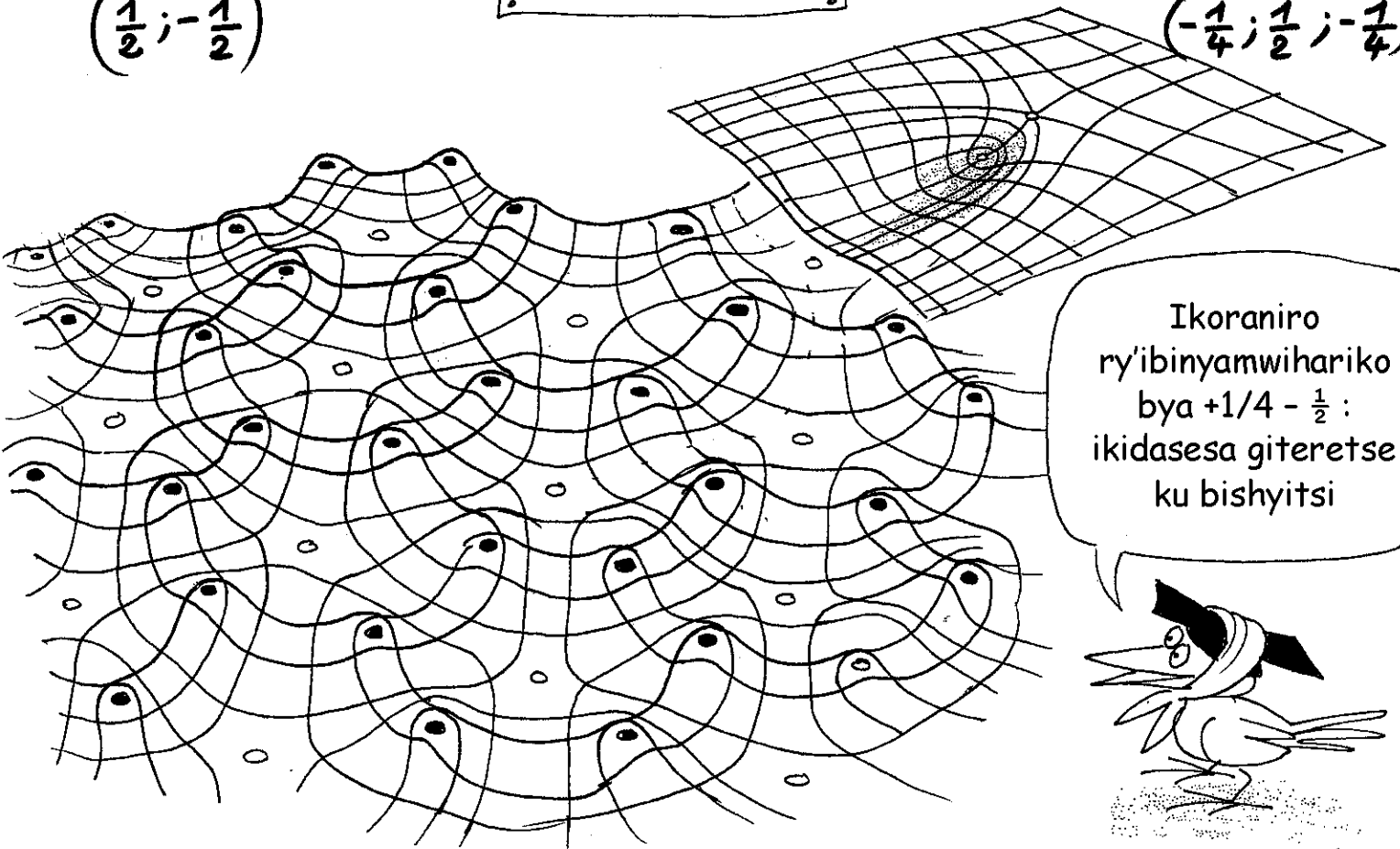

Ikoraniro
ry'ibinyamwihariko
bya $+\frac{1}{4} - \frac{1}{2}$:
ikidasesa giteretse
ku bishyitsi

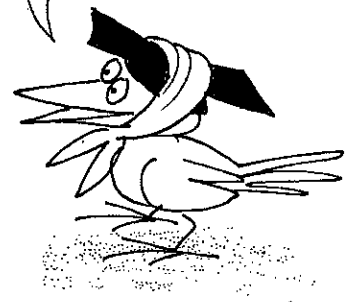

Nonese ubu uriho urakora iki ?



IMIRIMA YA SUMAKU.

Iyi sisiteme ikora imirima ya sumaku y'**IMITERERE IMWE** n'imirongo y'iyi mirima iba rero imirongo iteganye isanzwe.

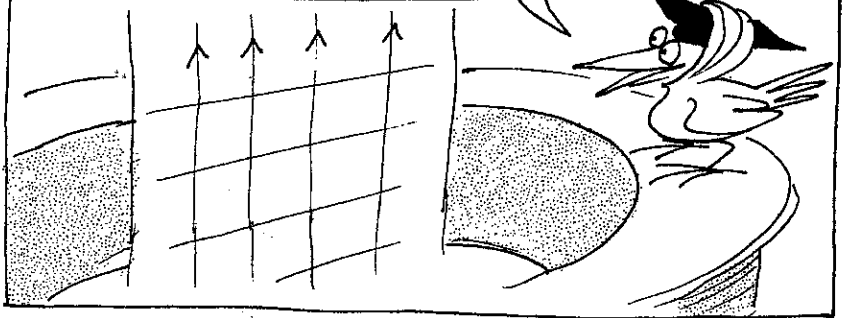

Noneho ubu nonjyeyeho i sipiri imwe igiye kubyara hagati ya yo umurima werekeza ahanyuranye.

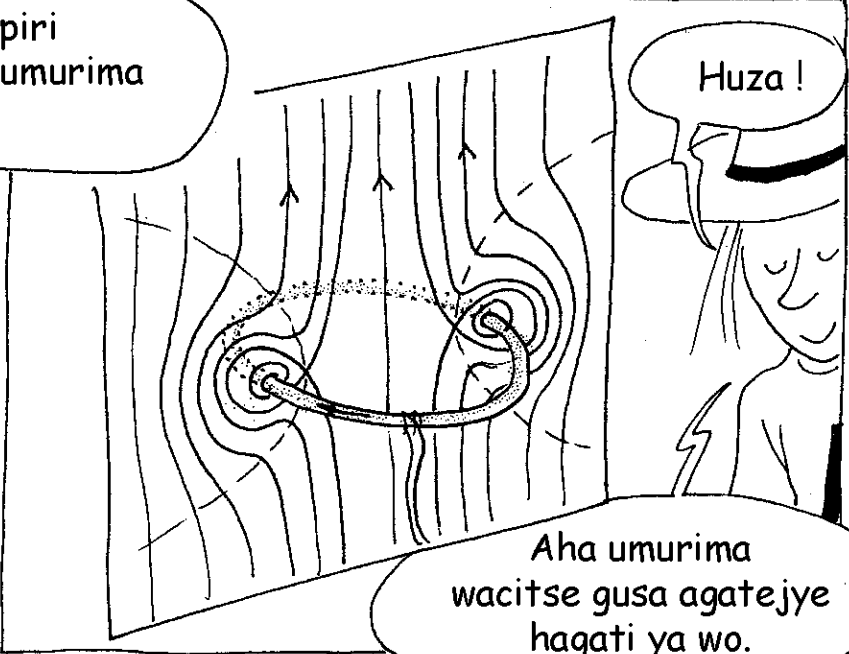
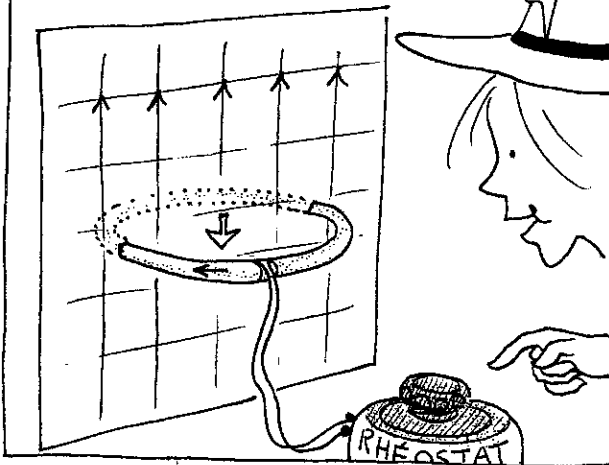

Aha umurima wacitse gusa agatejye hagati ya wo.

Gato ! wagaragaje **POLE** ebyiri (aho solenoyide yaciye mu kibyatarare k'igicapo) n'ibinyamwihariko bibiri by'urwego rwa -1. Ubiteranije bikangana na zero. Ibinyamwihariko negatifu bivuka aho umurima wa sumaku **B** ungana n'ubusa.

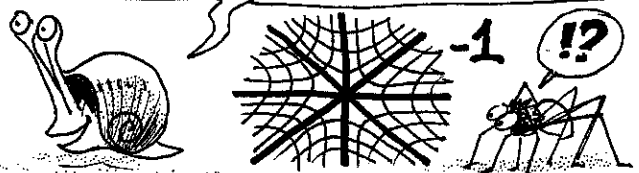
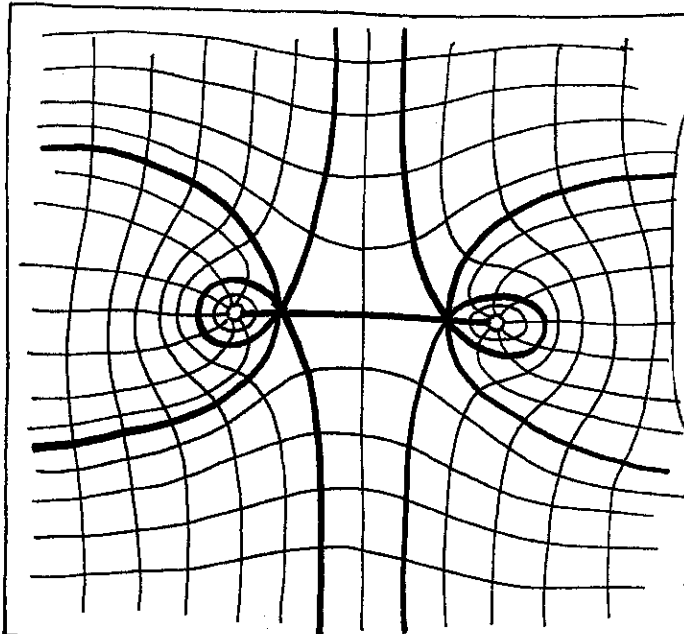

Mu by'ukuri, isisiteme yasimetiri y'ubwizengurukeho kandi dufite urujyero rwo kuboha ukoresheje imirongo y'ikinyamwihariko.

Ubu jyewe ngiye konjyera amashanyarazi ku buryo agaciro k'umurima wa sumaku hagati ya solenoyide kaba ubusa.

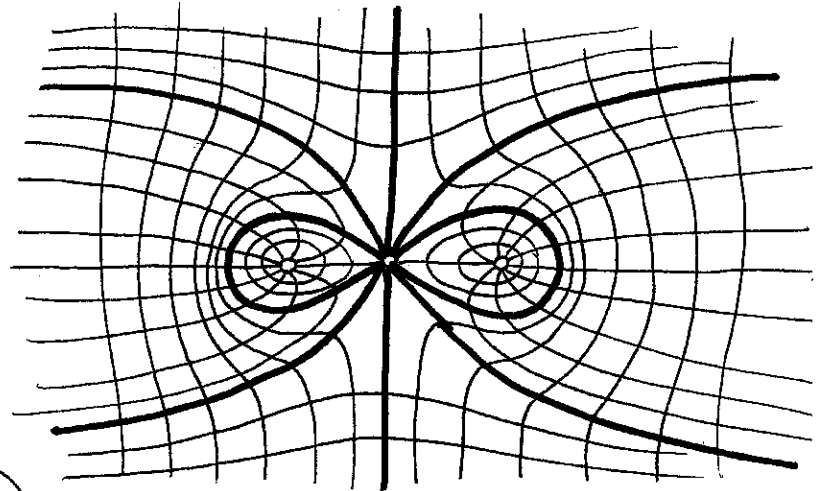

Utudomo tubiri tw'umurima wa sumaku ingana n'ubusa, mu kibyatarare cy'ishushanyirizo, twikubiye muri kamwe k'urwego rungana na -2 (urugero rw'ihuriro ry' ibinyamwihariko)

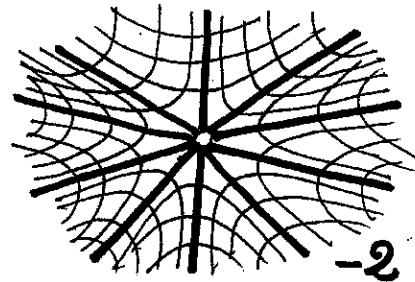

Iki kintu ni igiteshamutwe. Ese twongere umurima wa sumaku?

Ese ntibishobora guteza ingorane ?

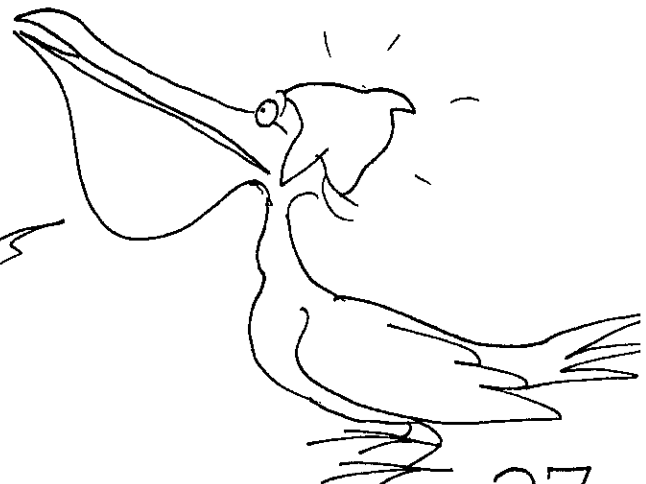

Ese icyo utinya ni iki Lewo ?
Ko dukora impinduka zidasubirinyuma
muri esipase-gihe ? Hari gose
100 gusa, muzehe wanjye...

Kuva ku gihe cy'URUKUTA
RWA BUCECE, Lewo areba
atumbereye cyane imirima
ya sumaku !

Ni igitangaza !

Umurima wa sumaku B
wihinduraniye hagati ya sipiri.
Ikinyamwihariko cyiciyemwo
kabiri, kibyara ibinyamwihariko
bibiri kimwe cyose gifite urwego
rwa -1. Twakoze vorutegisi
y'ingata mu buryo bwa
jewometiri y'ingata.

Kuboha, ibinyamwihariko
biri hose mu masanganzira
ya fisikye...

AMASARABWAYI ni indiri y'ibinyamwihariko. Muri iri buyenge ribyataraye rikozwe na za kare, ukuyemwo aga kare kamwe, uba uciye icyuho gisibwa n'ikinyamwihariko cy'urwego rwa $-\frac{1}{2}$ n'ibinyamwihariko bibiri by'urwego rwa $\frac{1}{4}$.

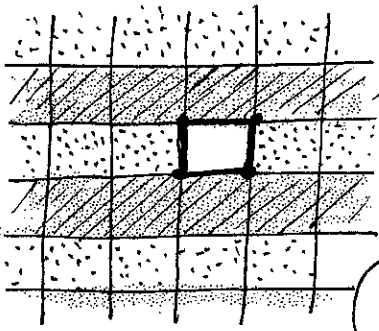

Ndakuramwo agakaro.

Ahangaha akabaraga ko **GUKUNJAKUNJA** kazatuma ihinduka ry'imipangire mw'iboha ribyataraye rihavutsa ibinyamwihariko bibiri by'urwego rwa $\frac{1}{4}$ n'ibinyamwihariko bibiri by'urwego rwa $-\frac{1}{4}$.

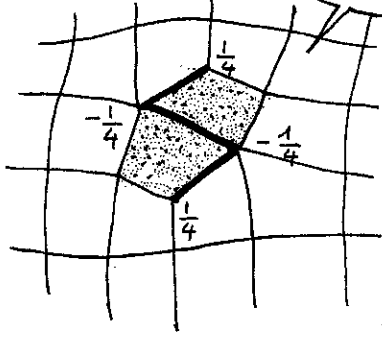
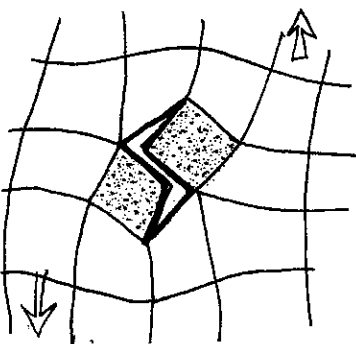
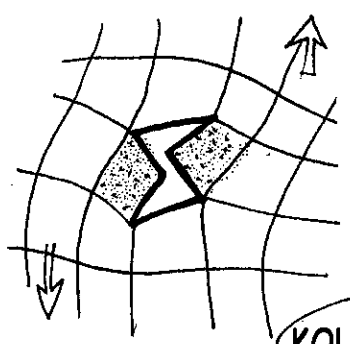
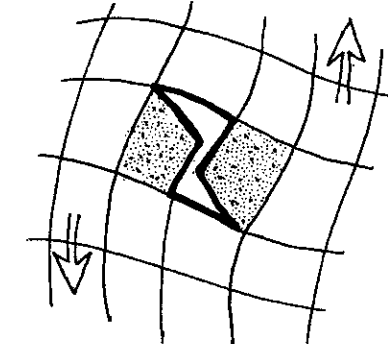
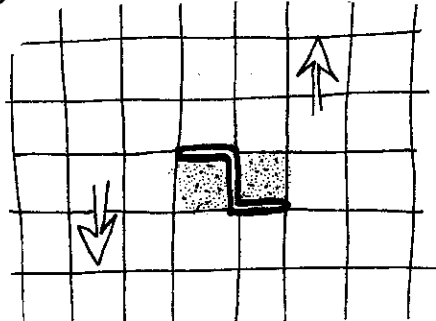
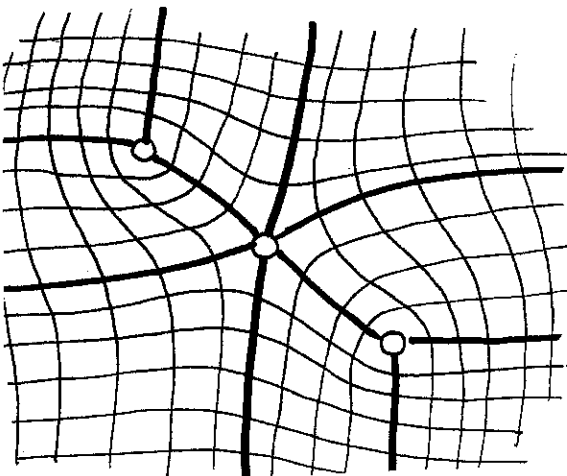
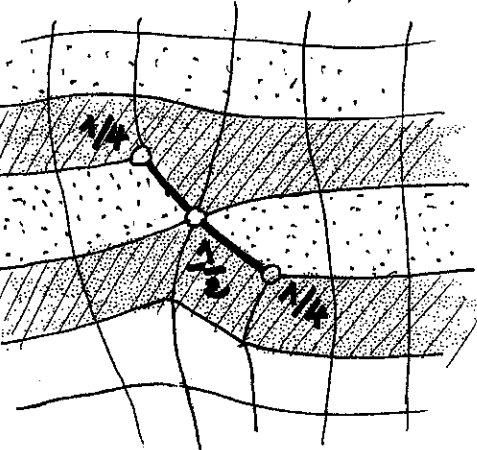
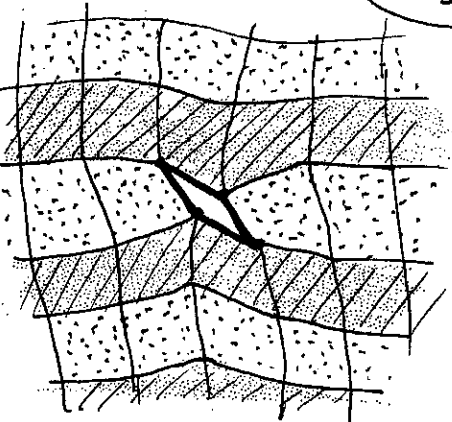

KOLOPE!

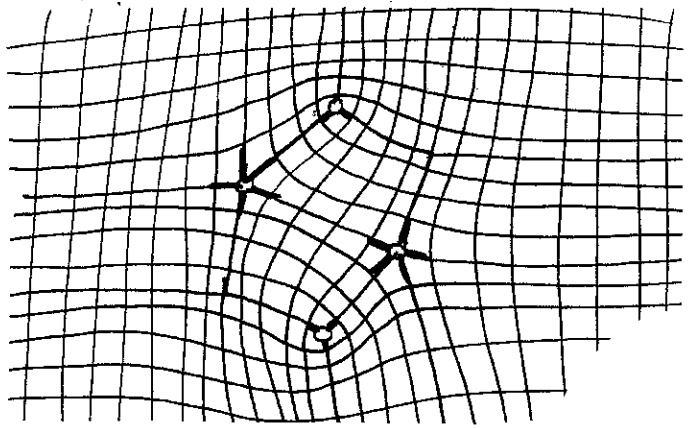

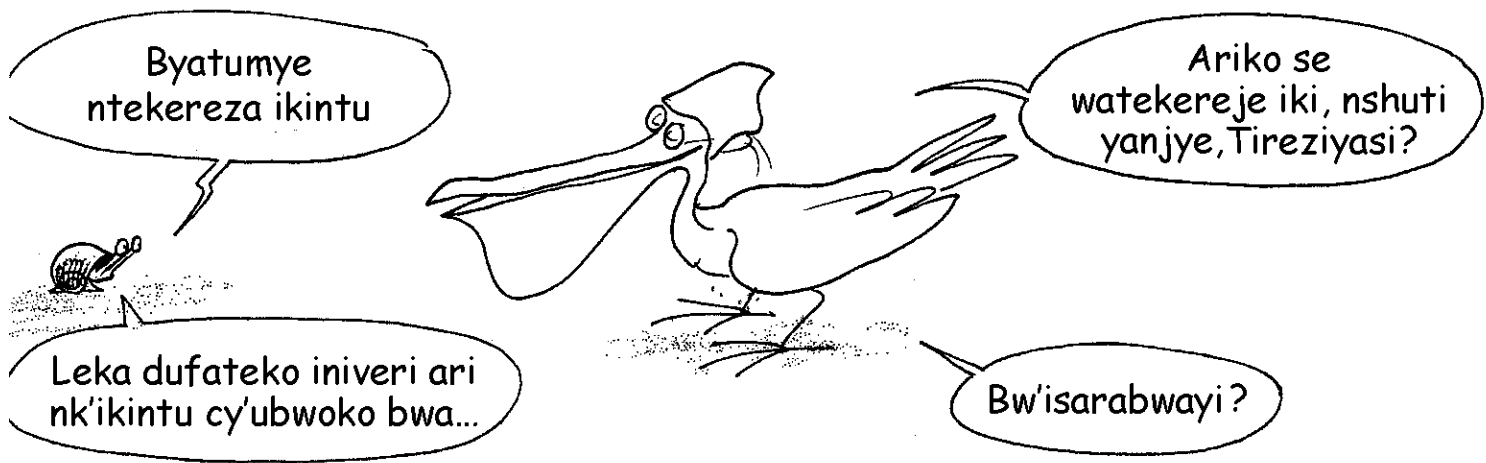

Byatumye ntekereza ikintu

Ariko se watekereje iki, nshuti yanjye, Tirezziyasi?

Leka dufateko iniveri ari nk'ikintu cy'ubwoko bwa...

Bw'isarabwayi?

Iyaba iniveri yarigizwe n'ubwoko bw'utururi, **IBICE BY'IBANZE** byakabaye ibyaho cyangwa ibimenagure, impuza z'ibinyamwihariko z'**IBYOMEKERANE** (*). Muvoma, cyangwa imikoranire ya byo yasa n'ihinduka ry'imipangire y'ibyo byose...

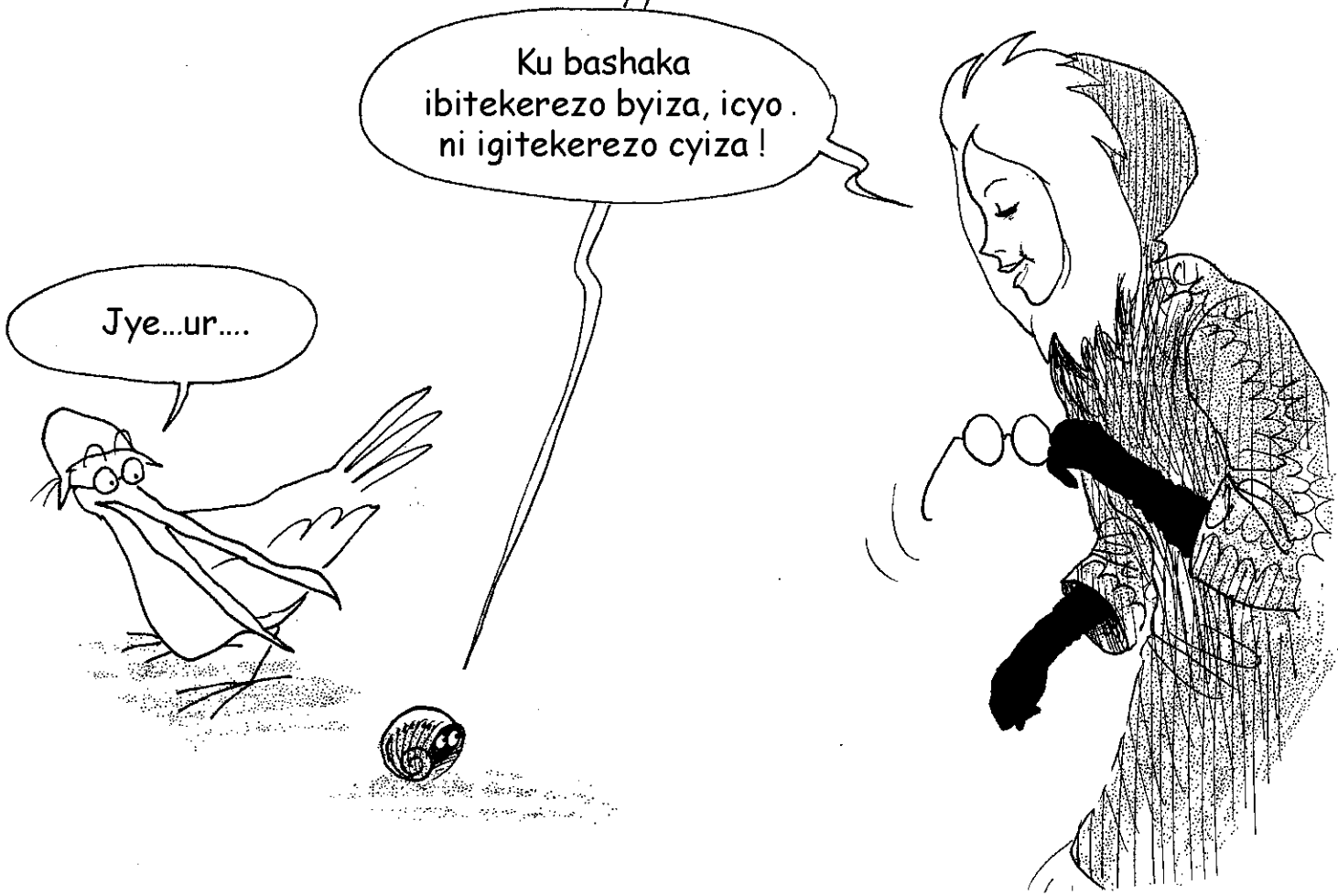

Ku bashaka ibitekerezo byiza, icyo ni igitekerezo cyiza!

Jye...ur....

(*) **KUBOHA** birebana n'ibintu bya dimansiyo 2. **KOMEKANYA** bihwanye n'ibyo ariko kuri dimansiyo z'umubare wo hejuru.

Ibikurikira byose bigiye gusobanurwa dukoresheje
INKURIKIRANE Z' IBISHUSHANYO BISOMWA
bigaragazwa n'inyuguti A,B,C na D.

Ubuyobozi

A

IHINDURANYA
RY'URUGORI
RWA MOBIYUSI
MU NYABUSO
YA BOYI

INYABUSO BWA BOYI

Byiza, twishimishije
rwose, ariko, hagati aho,
uriya munyagwa Amundeseni
aracyari mw'isupu...

Ariko ntabwo
twari twamenya neza
icyo iriya mburagasani
ya palaneti itagira pole
y'amajyepfo ari cyo!

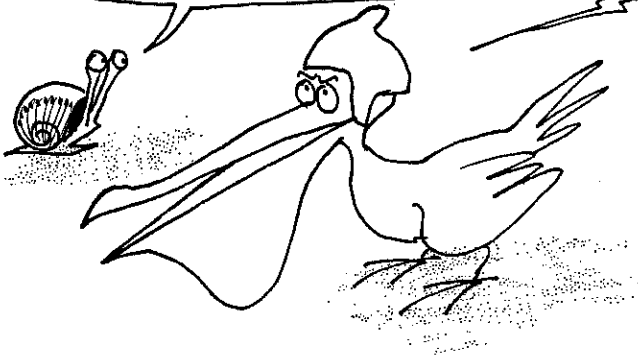

B
NKUKO :
UMUZINGI-MUSOZO
N'ITSINDA
RY'IHWANIRO
MU BWARYO

C
GUSHYIRA
MW'IHWANIRO
RY'UTUDOMO
NDWANYAPODALE

Buretse...kugirango ibeho ifite pole imwe,
ikimenyimenyi cyayo cya Ewuleri-Puwenkare kigomba
kuba kingana na rimwe. Kandi ubundi irasa n'aho
ari **INYARUHANDE RUMWE**.

D
IKIGARAGARA
NK'ICURIKWA
RY'IGIHE

Urugori rwa Mobiyusi rufite ikimenyimenyi kingana n'ubusa. Nk'akarorero, nshobora kurudoderaho idiskye isanzwe nkurikije umuzingi ufunze, ufite nawo ikimenyimenyi kingana n'ubusa...

$\chi=0$

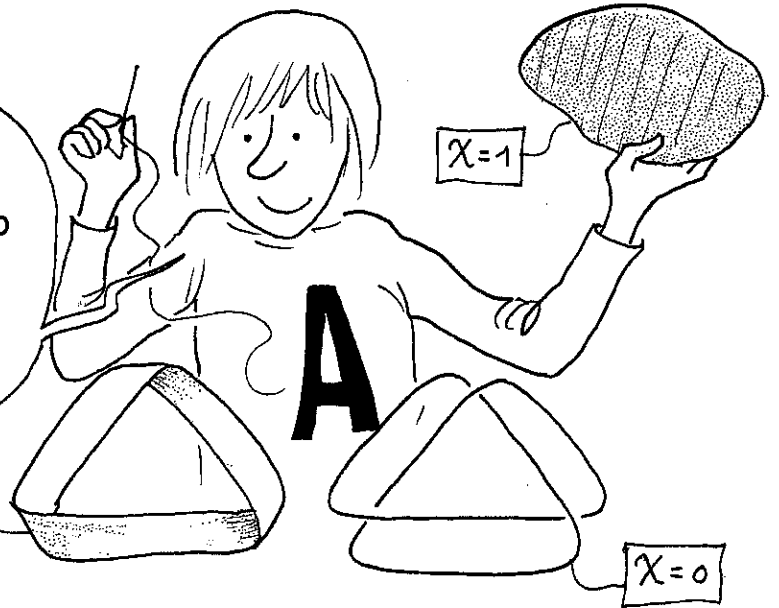

Uwo mwenda mushya uzaba ufite ikimenyimenyi kingana na rimwe, kandi waba ari inyabuso ifunze y'inyaruhande rumwe. Ariko se, aho kudoda, kuki tutakoresha ubugeni bwa TARAVÉRISINE ?

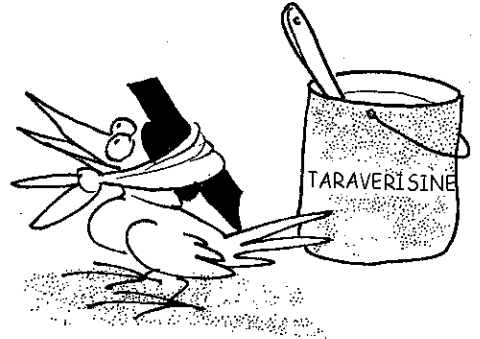

Amateka y'urugori rwa Mobiyusi rwihinduramwo inyabuso ya **BOYI** wabirebera ku nkurikirane z'ibishushanyo **A** na **B**. Reba igishushanyo cya nyuma:

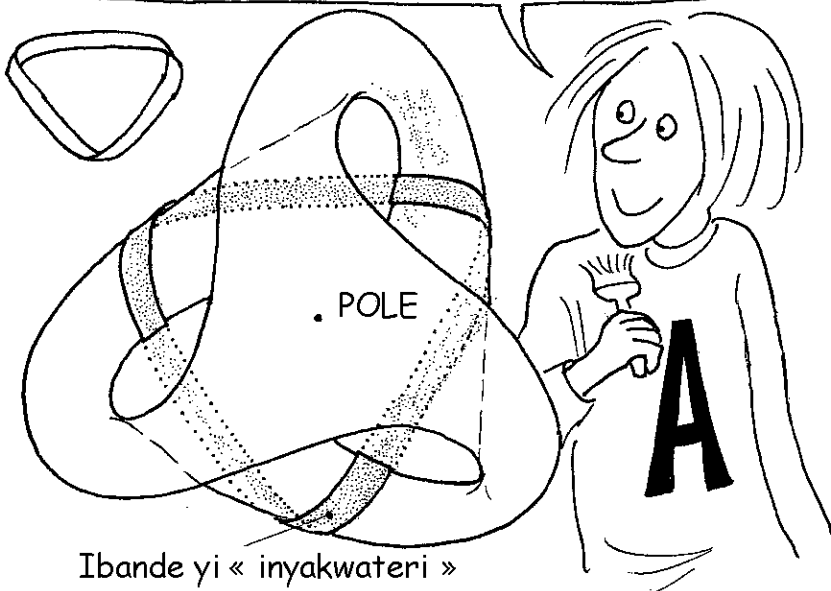

Ibando ye « inyakwateri »

Dore ama « **PARALELE** » y'inyabuso ya **BOYI**. Kandi ni injyanambere y'**UMUSOZO** w'urugori rwa Mobiyusi ruhura n'igice **A**

Paralele zisetsa...

Ni akazi k'UBUBOSHYI,
Lewo. Gusa ni ugukomeza « za meridiye »
z'urugori rwa Mobiyasi zikazagera ku ndiba
y'inkangara, kugeza kuri pole.

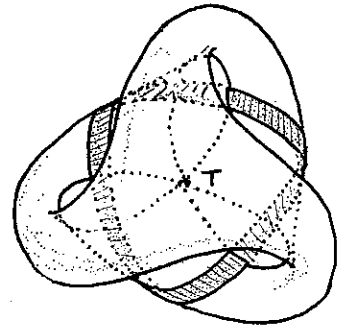

INYABUSO YA BOYI
N'URUGORI RWA
MOBIYUSI RW'IBANZE

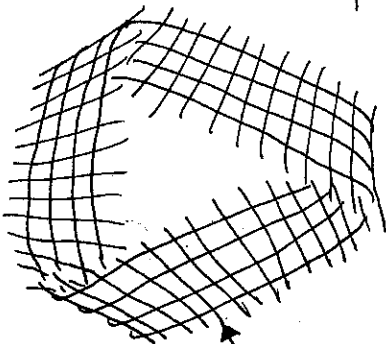

MERIDIYE

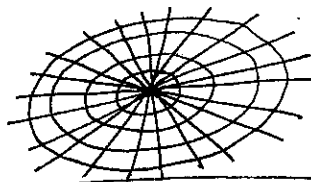

Mu yandi magambo,
tugomba gusudira,
biriya bishingo byibunza
by'urugori rwa Mobiyusi,
n' « ibyindiba y'inkangara »

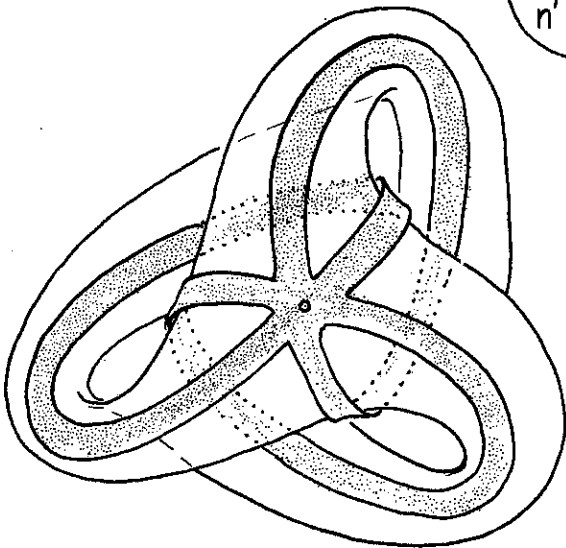
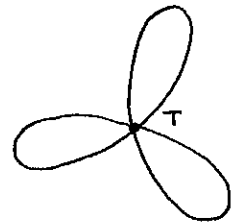

IBYEGERANYE n'ayo
ma meridiye ni ingata za Mobiyusi
z'igice cy'umuzenguruko.

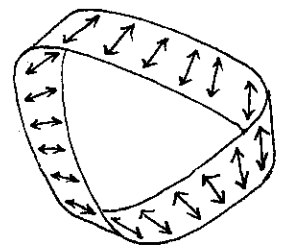
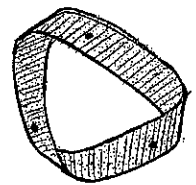
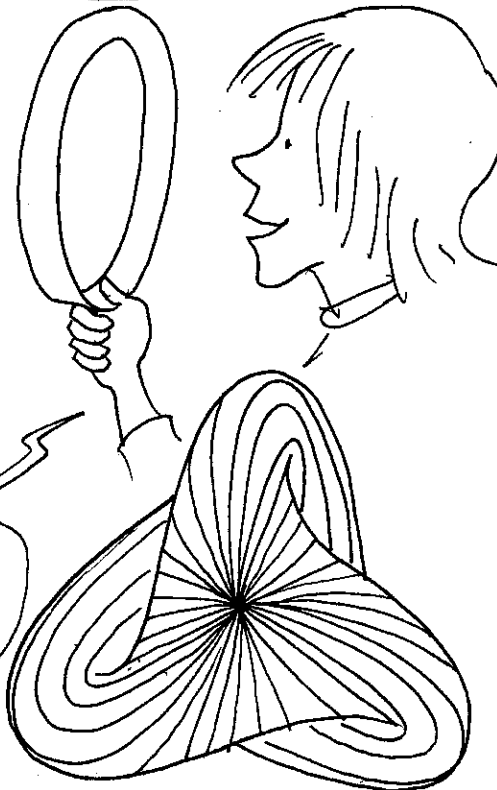

Umudeli wa mbere w'inyabuso ya Boyi hamwe n'igiteranyo
« meridiye » + « paraleli », watekerejwe bwa mbere n'umwanditsi
w'iki gitabo naho igishushanyo cya byo cyakozwe nyuma yaho
n'umutatsi w'umubaji Maksi Soze kandi kiragaragara mu cyumba
cy'Ingoro y'Ubuvumbuziy'i Parisi mu Bufaransa.

Ubuyobozi

Twagendagenze kuri imwe muri izo ngata igihe twaturukaga kuri « POLE Y'AMAJYARUGURU », turiho dushaka « POLE Y'AMAJYEPFO »

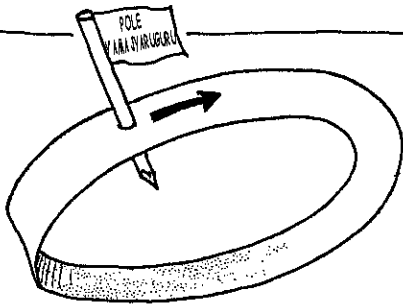

Nk'uko byumvikana twatungutse ku gasongero k'urumambo rwa Peri !

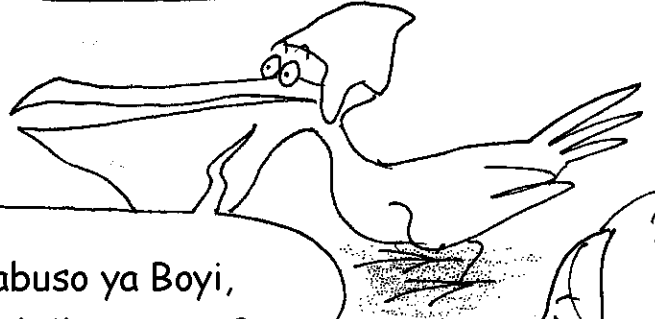

Ariko se nimba twaragendajyenze ku nyabuso ya Boyi, byagenze bite ngo nti tubone uturere tw'i yinjiranamwo ?

Urabizi neza ko iriya **SHUSHO** y'i yinjiranamwo ari mu by'ukuri ukwibira k'**INYABUSO YA BOYI** muri **ESIPASE YA DIMANSIYO ESHATU YO KWEREKANIRAMWO**. Mu by'ukuri inyabuso ya **BOYI** n'icupa rya **KELEYINI BIBAHO NK'IBINTU BYA DIMANSIYO 2 KANDI NTIBITERWA NA ESPASE BABYEREKANIYEMWO**.

Dore uburyo bwiza bwo gusibanganya iryo yinjiranamwo.

Byiza, ikintu cyagaragaye : ipalanete ni inyabuso ya Boyi kandi hari i pole imwe rukumbi.

Ntabwo arijye wajya kubwira ibyo uriya munyagwa w'umugabo Amundeseni.

Aracya hungabanye.

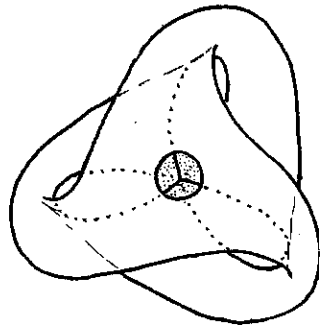

INGATA YA MOBIYUSI Y'UMUSOZO WA SERIKYERE

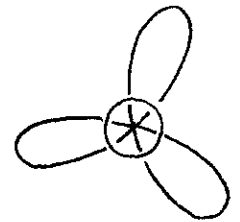

BOYI-KYIBE

Yeee byiza ariko jye ndacyafite....

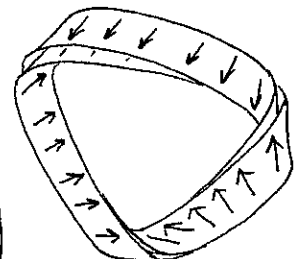
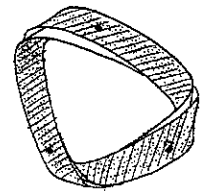

Jye, yenda ndasa n'ubatangura ariko ndahamya ko, nakoresheje n'ayo mashusho, iyo mikatire, iyo mirebere inyuranye, ntarasobanukirwa icyo inyabuso ya Boyi aricyo...

Ufite ikibazo mu gusobanukirwa topoloji ya cyo ?

Yacyo ?... eeh... yego... bishobore kuba ari ibyo.

Buretse Lewo, nabonye ikintu kiza kugufasha.

Lewo, siferi cyangwa kyibe, ni bimwe ! topoloji zimeze kimwe, ibimenyimenyi bya Ewuleri-Puwenkare bimeze kimwe, ubuzingye byose bumeze kimwe.

Ariko...yego

N'iki, ni INGATA

Noneho rero, iyi ni iKELEYINI-KYIBE

Rwose pe.

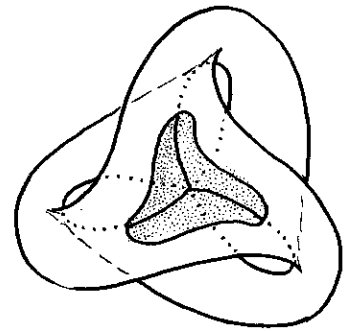
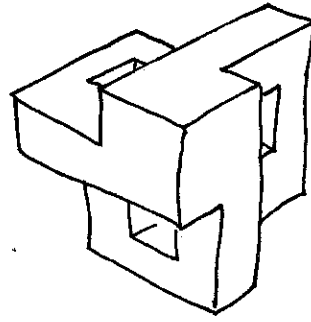
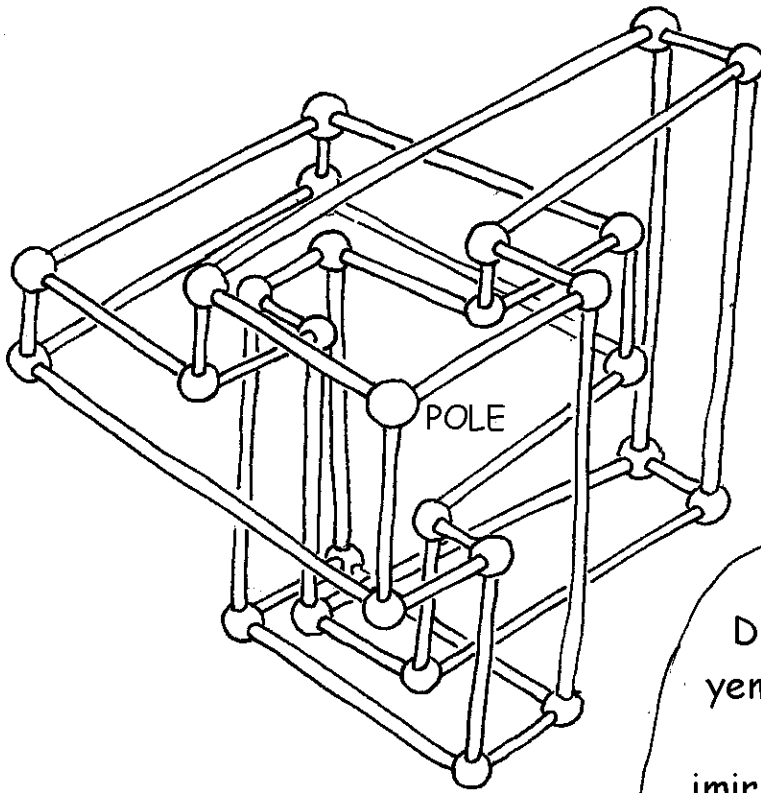

Dore **BOYI-KYIBE**
yemejwe na Lanturulu:
amasonga 28
imirongo yo mu nguni 43
impande 16
 $\chi = 28 - 43 + 16 = 1$

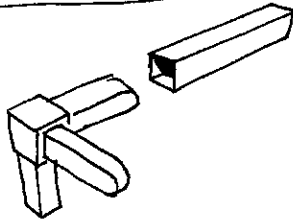
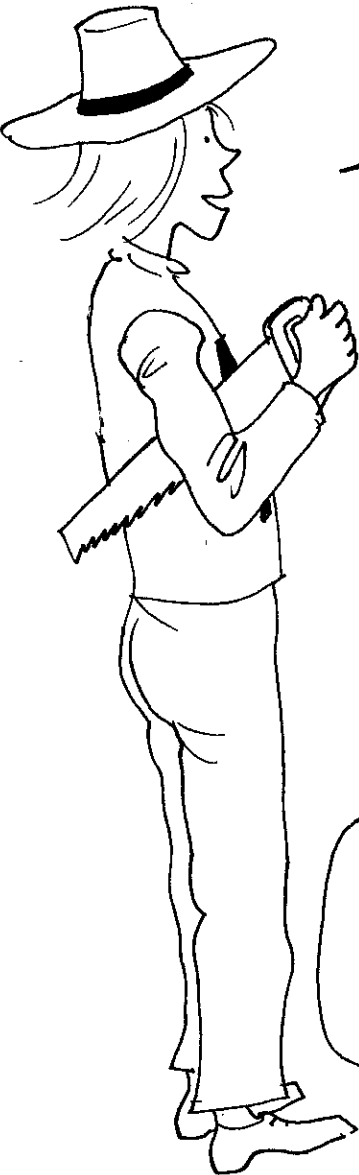
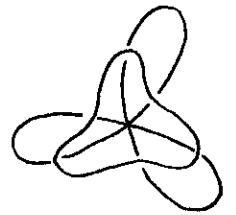

Dushobora gukora modeli
nziza twifashishije
ibikoresho bya etajere
REYNOLIDESI (imiheha
ya kare ikozwe muri durale,
ibice by'imfuruka bya
palasitike)

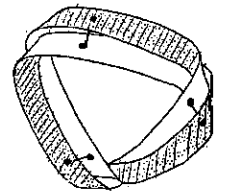

IPaje ikurikira,
harerekana imikatire yabyo
ituma mwikorera ubwanyu
BOYI-KYIBE yanyu.

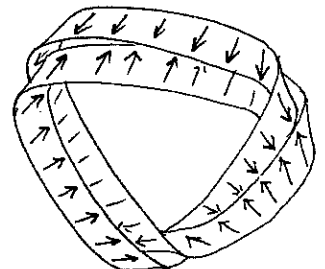

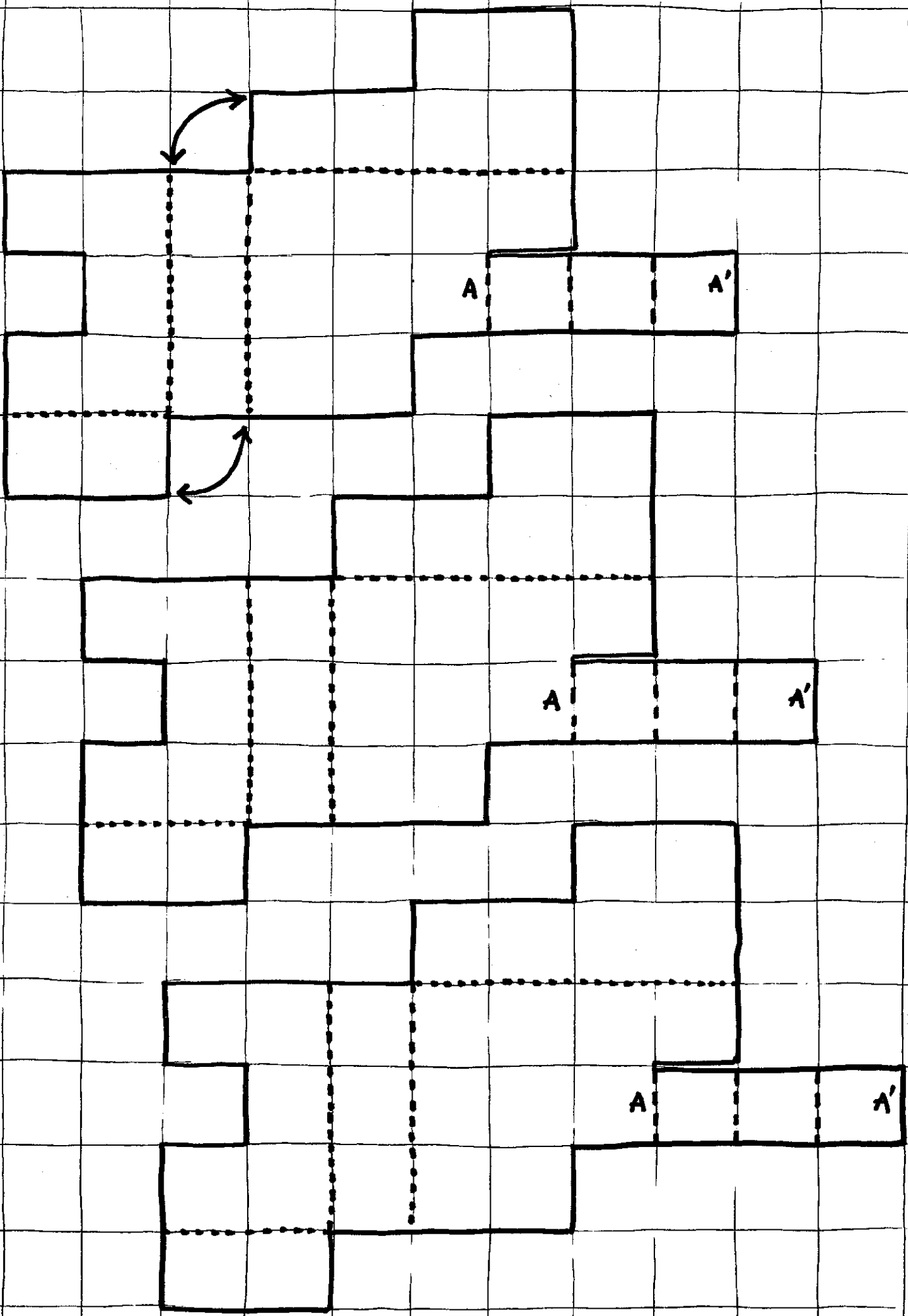

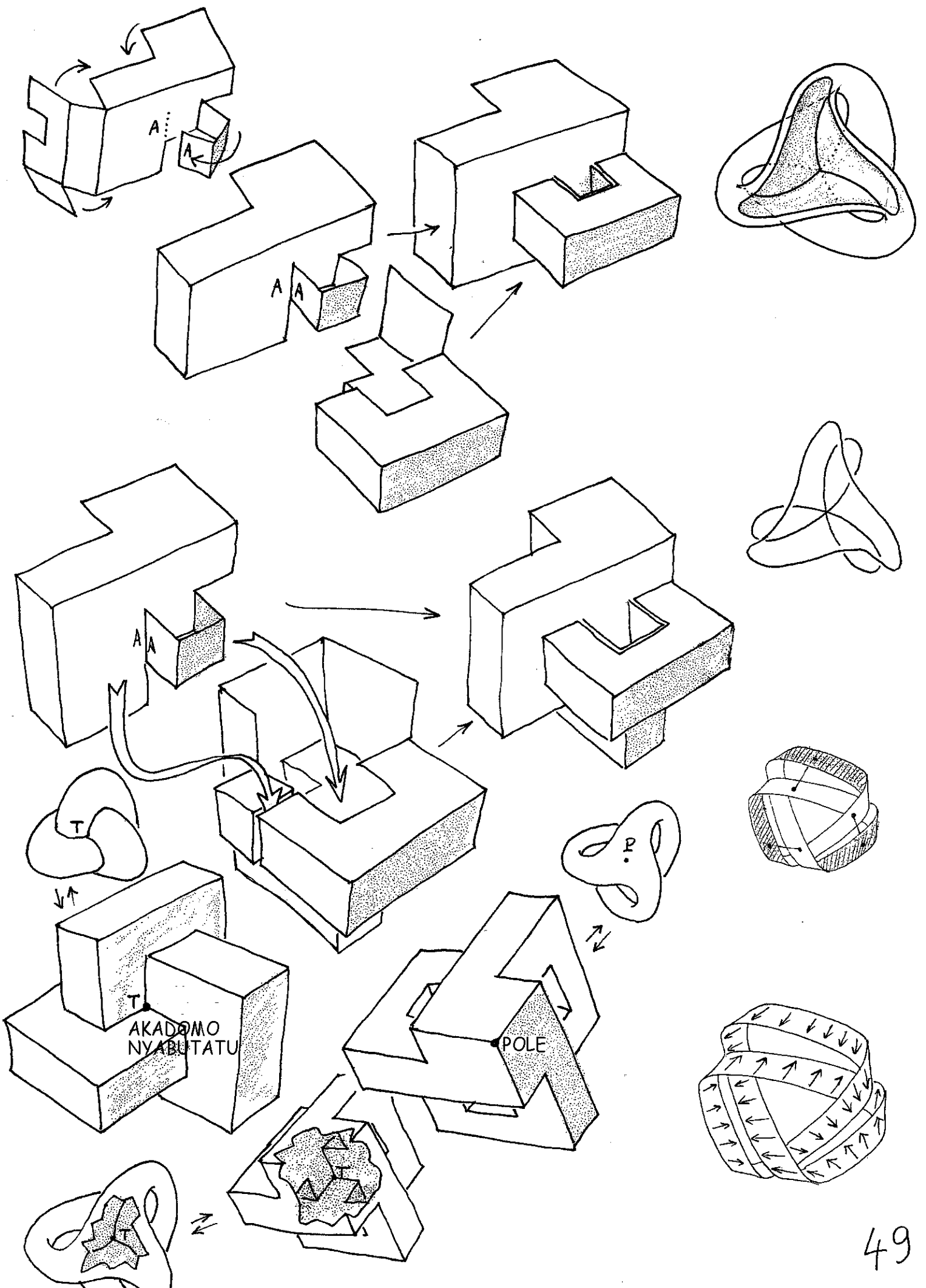

GUFUNIKA

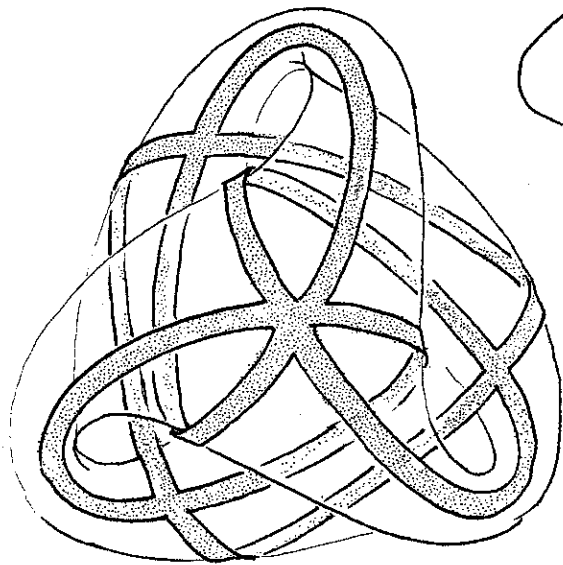

Noneho rero,
niwo musozo
w'inkuru ?

Oya, hari
igaruka ryabyo
ritunguranye...

Urwambiko rw'inyuma n'imbere
rw'ikintu cy'uruhande rumwe,
KITAGANISHWA, bitanga **IKINTU
KIMPANDE EBYIRI, KIGANISHWA**
kandi gifite ikimenyimenyi
cyikubye bibiri.

Ese ibyo bikuru ni bwoko ki ?

Biroroshye, fata urugori
rwa Mobiyusi, urusige irangi ku
ruhande rwarwo **RUMWE RUKUMBI**,
nurangiza usokororemwo urwo rugori

... k'uburyo usa n'usigarana irangi gusa !

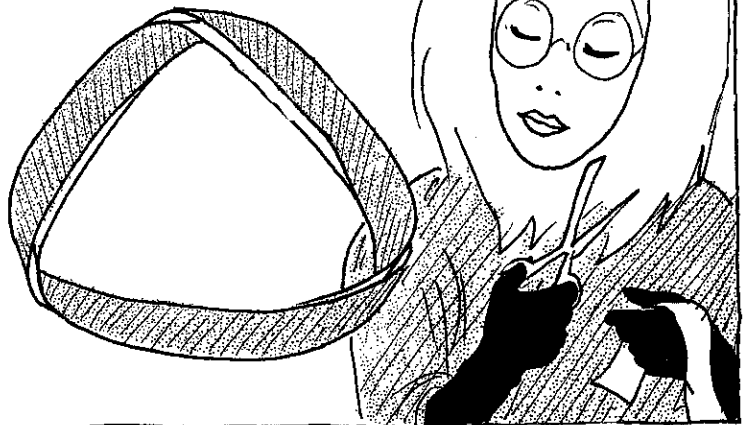
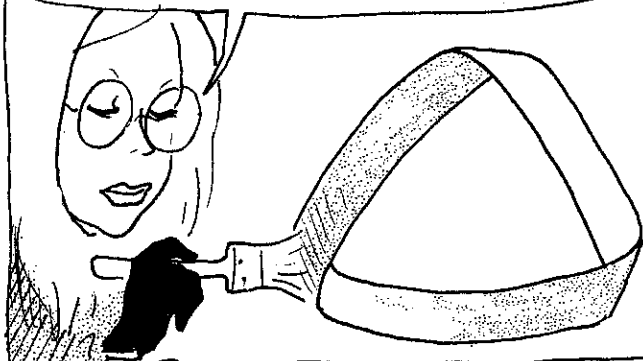

Iyo bande nshyashya, yifungiyeye ubwayo kuri yo, ifite impande ebyiri, kuko rumwe rwahuraga n'urugori rwa Mobiyasi. Ubundi kandi ushobora kwitegereza neza igice cy'amashusho C :

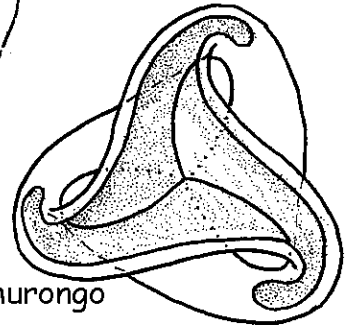
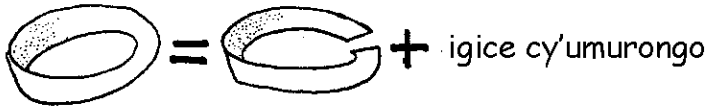
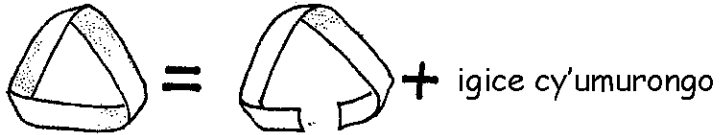
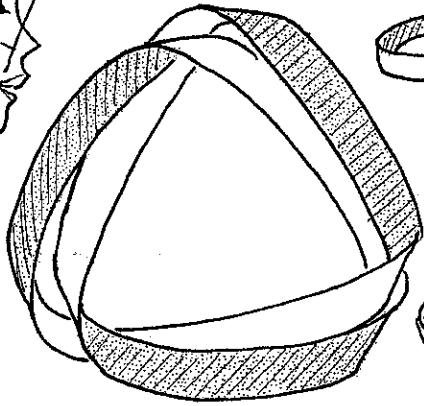

Ikimenyimenyi cya cyo n'icyurugori rwa Mobiyasi byose binga n'ubusa.

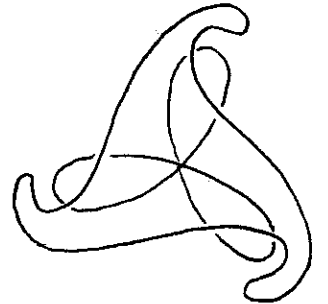

Buretse ndebe...iyo nsize irangi...
i CUPA RYA KELEYINI K'URUHANDE RWARYO RUMWE
 narangiza ngasokororamwo iryo cupa ariko ndahungabanije
 iryo rangi, mbona ikinyabuso **GIFUNZE, GITUNGANYE**
NEZA, cy'IMPANDE EBYIRI kandi gifite ikimenyimenyi cya
 Ewuleri-Puwenkare kingana na $2 \times 0 = \text{zero}$.

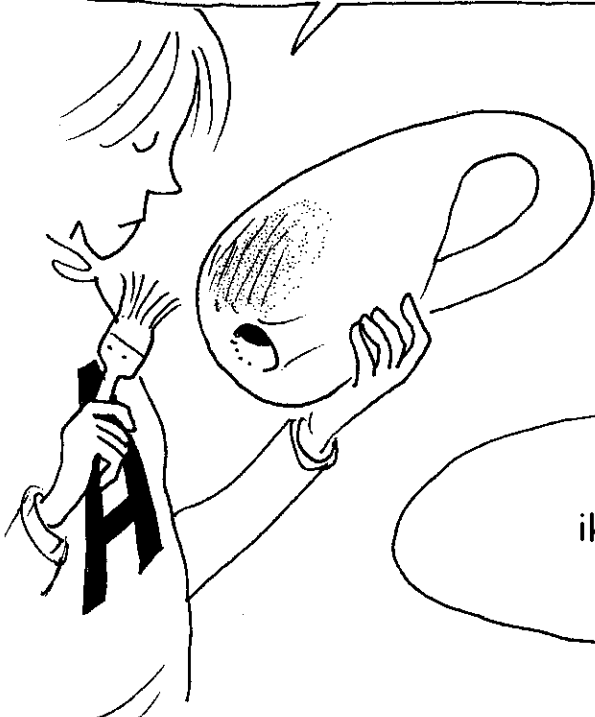
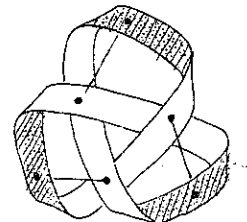

Ni ukuvuga
 ikihingukemwo
 cy'ingata

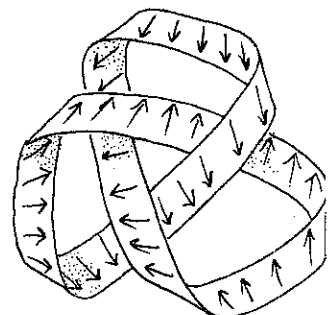

Tireziyasi, urihe ?

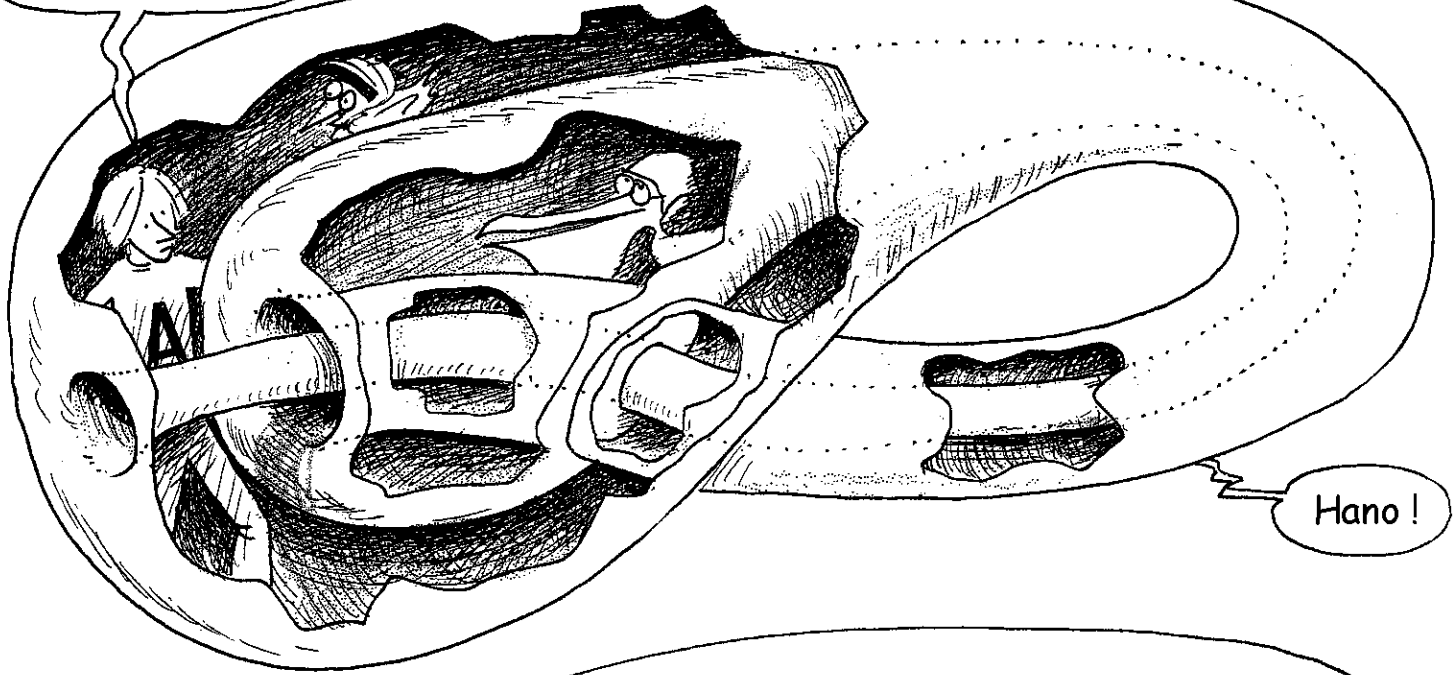

Hano !

Nkomeje ntyo,
ngafata inyabuso ya Boyi, nkayisiga irangi
hanyuma ngasokororamwo iyo BOYI kuburyo iryo rangi
rigumana iforoma yaryo nk'uko ryasizwe, nasigarana inyabuso
IFUNZE, ITUNGANYE NEZA, Y'IMPANDE 2 kandi
ifite ikimenyimenyi cya Ewuleri-Puwenkare
kingana na $2 \times 1 = 2$...

...ni ukuvuga
**IKIHINGUKEMWO
CYA SIFERI**

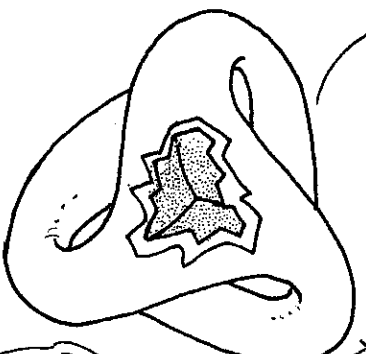

Ese, **MU BY'UKURI**,
nshobora « kwigizayo » iyi nyarwa
ya siferi nkanayihinduramwo
siferi « isanzwe » ?

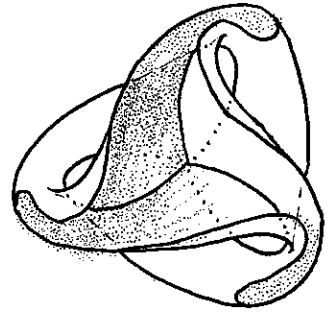

Ukoresheje **UBUJENI**
BWA TARAVERISINE, nta
kibazo kandi bikorwa kimwe
kubijyanye n'INGATA.

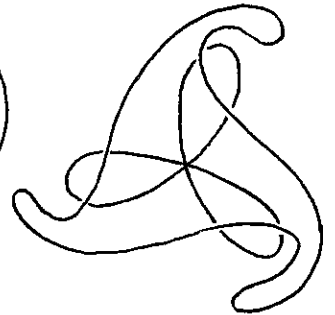

Dukore duherereye inyuma.
Reka dufateko nshaka
« guhinduranya » i siferi
utayizinze !

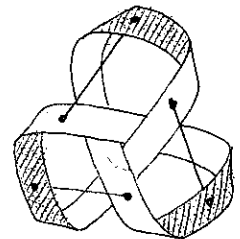

INYURANAM WO
RYIMIYOBORO
RYARANGIYE.



Ni ukugomba
gukoresha
RETERESISOLE

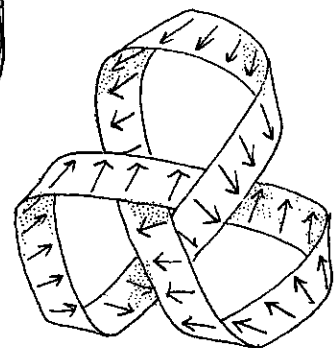

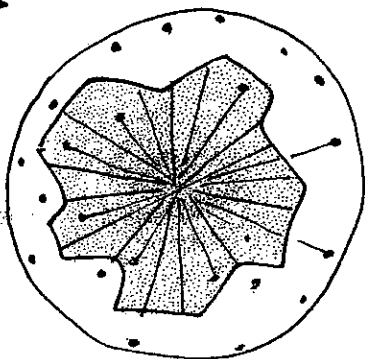

Dutangire duhuza buri kadomo ka siferi na **ANTIPODE YAYO** dukoresheje imigozi yanyujijwe muri **RETERESISOLE**.



Iyo migozi iriyegeranya kuburyo uburebure byayo buba ubusa, ariko kandi ubuso bya siferi buguma ari bumwe, budahinduka. Bityo tuzana buri kadomo mw'**IHWANIRO** na **NDWANYAPODALE** ya ko.

Ariko ibyo muzabibona mu yindi alubomu, yajyenewe **IHINDURANYA RYA SIFERI**. Hagati aho, ikurikirana ry'amashusho ya filime **C** yerekana uko **EKWATERI** ya **SIFERI** yikunja, igahinduka **EKWATERI** ya **BOYI**. Ku bigaragara, pole y'amajyaruguru iraza ikiyomeka kuri pole y'amajyepfo.

Ubuyobozi

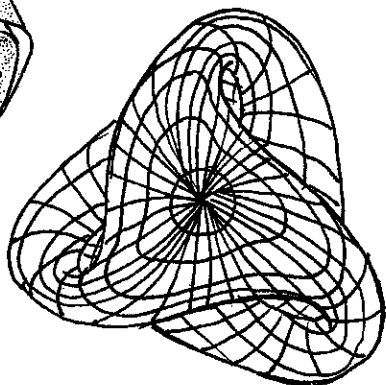
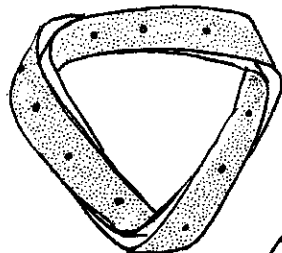
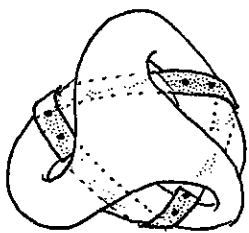
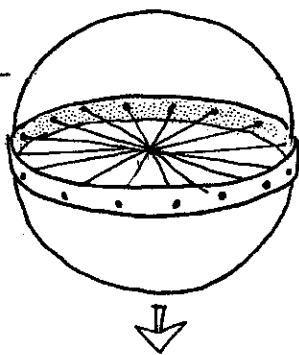

Meridiye na paralele zose za siferi ziraza zimwe zikorosa izindi.



Tekereza igitagangurirwa kiba ku nyabuso ya BOYI iboshye k'uburyo imitambiko yayo iteye nka za palalele naho imishingo nka za meridiye. icyo gitagangurirwa kizagirango gituye... kuri siferi !

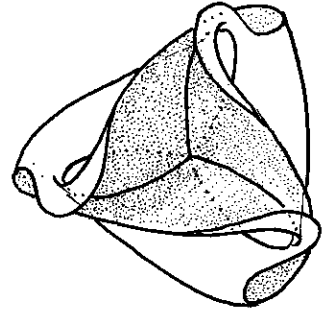

FUNGA IZO « NGOMA Z'AMATWI » ESHATU.

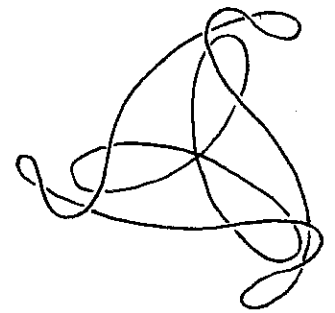

Byiza, ubu ko ifunguro rya sasita rihari, ngiye gutembera gato.

INZIRA IGITAGANGURIRWA CYACIYEMWO

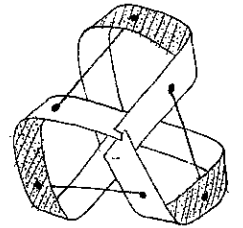

Aho re, ikindi kidasesa. Mugenzi wanjye atuye k'urundi ruhande kandi na we yakaciye isazi.

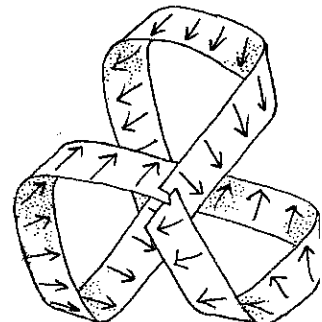

Nta muntu ureba?
Byiza...ngiye kurya kariya gasazi ke.

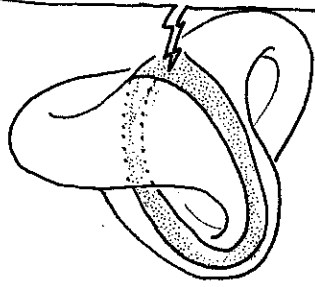

BURP!

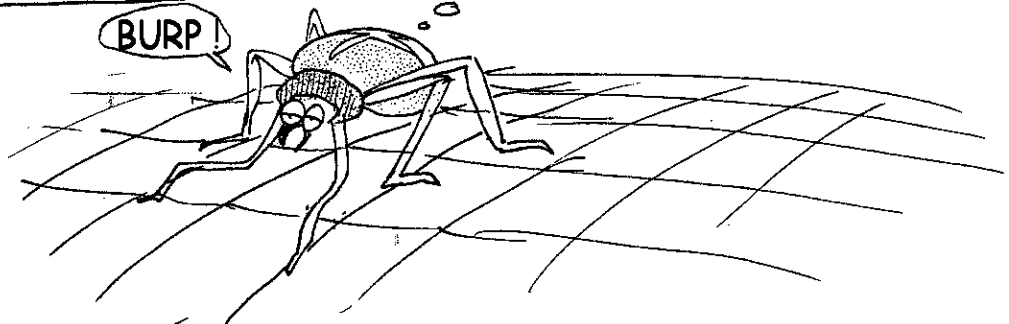

Eee..., dutahe.

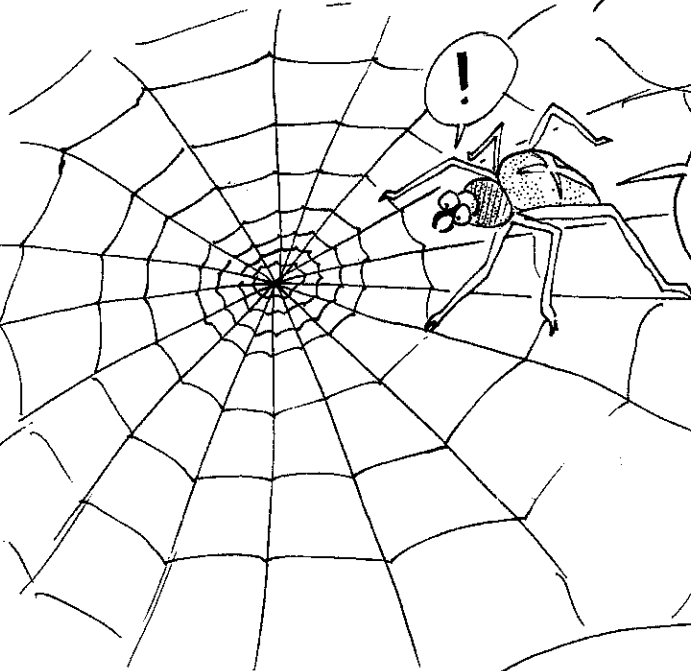

Mbega ubugoryi !
igihe nari nagiye, cyagitagangurirwa
kindi cyageze hano kimiragura
kagasazi kanjye !

Hi Hi Hi



Mu by'ukuri, hari igitagangurirwa kimwe n'isazi imwe

Ngiye kugategereza, igihe kazongera
gukandagira hano, nzakereka...

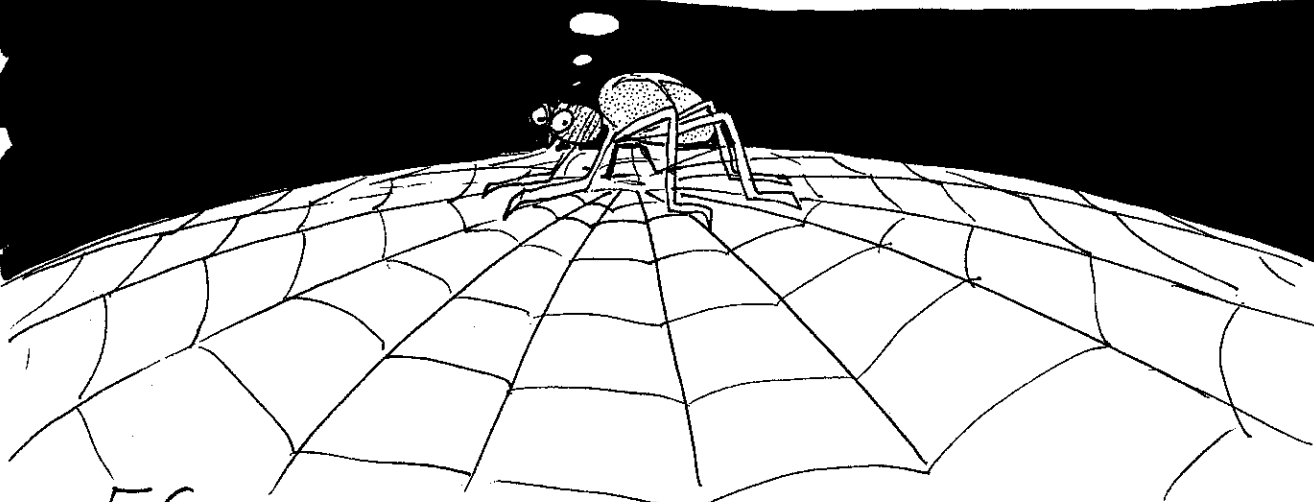

Ariko...inkuru
y'igitagangurirwa... yampaye
igitekerezo. Ku byerekeranye
na Amundeseni, dufite
igisubizo.

Bwana Amundeseni,
ibintu byose byatunganye !
twabonye pole yawe
y'amajyepho.

Ibyo se bite ?

Ah...

Muronjyeye
muragiye ariko
mujyane n'iki...

Pole
y'amajyepfo

Na Peri
twamuhaye
nk'iryo.

... kandi icyo
ukora gusa ni
UKURISHINGA !

KANDI BYOSE
BYAGARUTSE
MU BURYO BWIZA...

Pole
y'amajyaruguru

Pole
y'amajyepfo

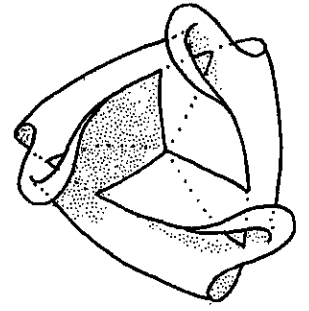

ISERUKA
RY' « AMATWI »

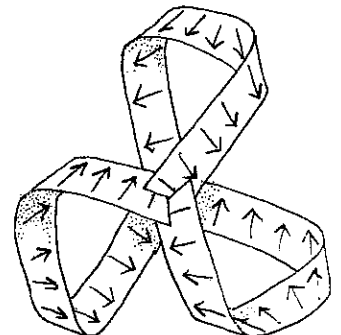
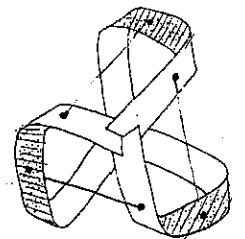
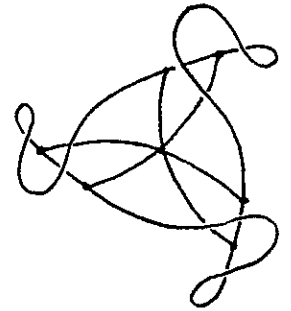

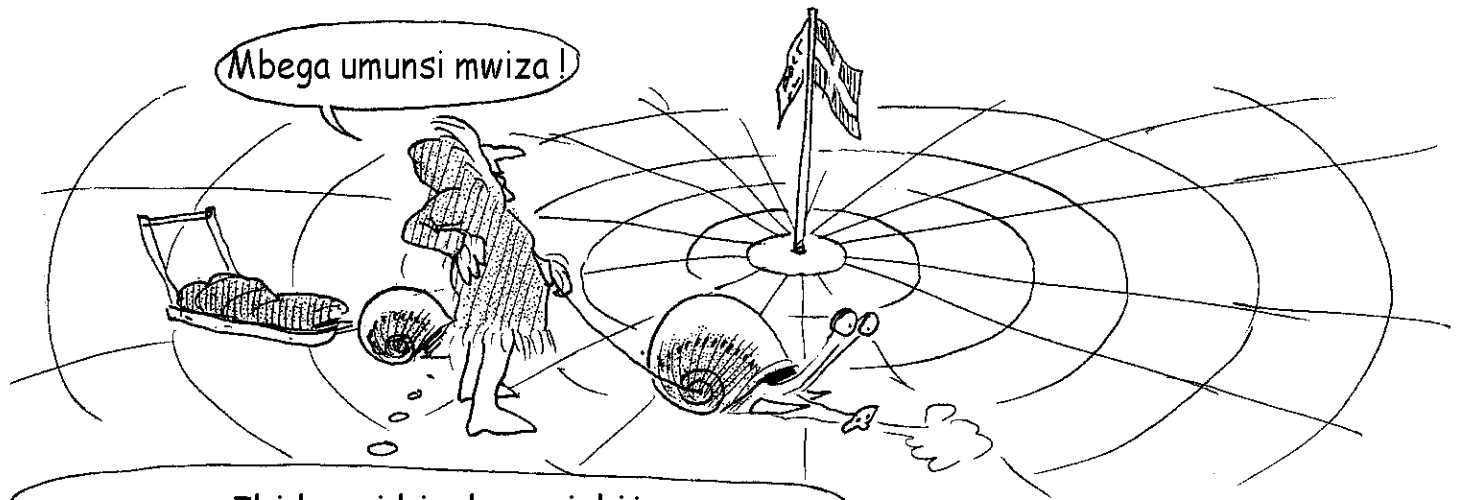

Ibi byari biyabavugishije.

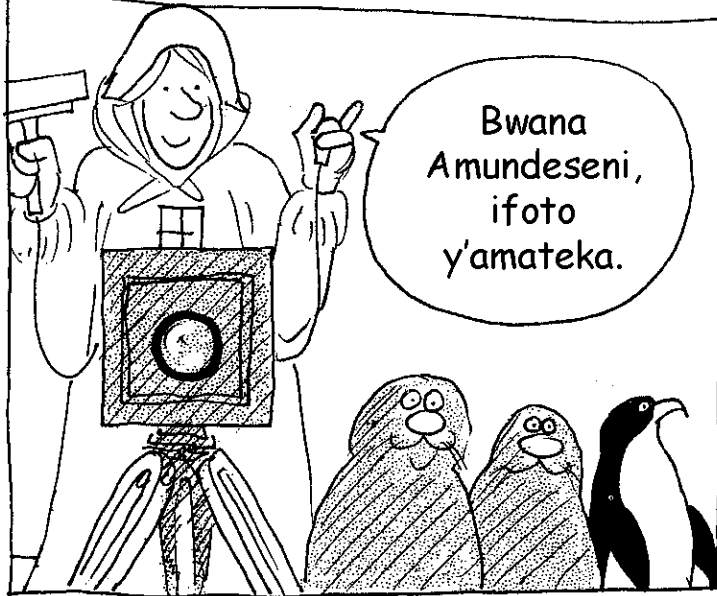

Bwana Amundeseni, ifoto y'amateka.



Ni mumvire aho mugende, ndashaka kuba jyenyine kuri iyi foto y'amateka.

POLE YAMAJEPPFO

Muri siyanse, ni nk'ahandi hose. Rimwe na rimwe, biba byiza kudacukumbura cyane...

... buri pole, mu mwanya wa yo ; icyo gihe n'inka zizaragirwa neza...

Kandi noneho, iyo ducukura, muni ya pole y'amajyaruguru, yenda twari kuzagera ku bintu bitunguranye.

Kandi hari kuboneka abo bibabaza, igendere.

Byiza, dore icyo cyo kirakemutse. Ariko se Lanturulu ariho arakora iki ?

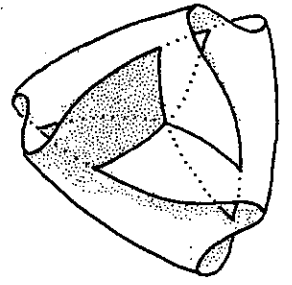
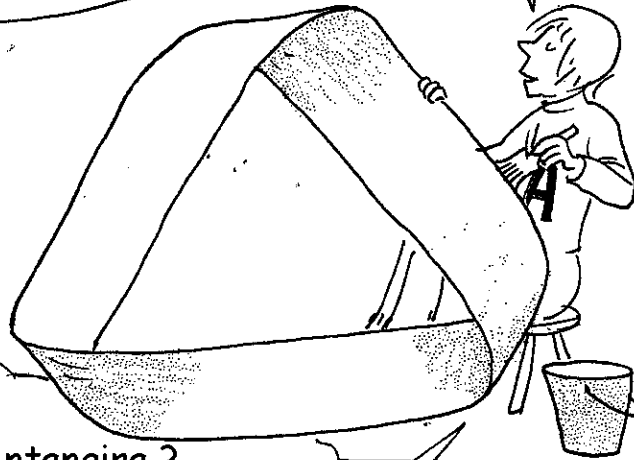

Ese uzi icyari cyo indorerwamo itagira irangi-ntangira ? Iyo uyirebyemwo, ubona ibiri inyuma ya yo n'ibikugarukaho. Neza na neza, ubu ndiho ndahindura uru rugori rwa Mobiyusi ngo ruvemwo indorerwamu itagira irangi-ntangira.

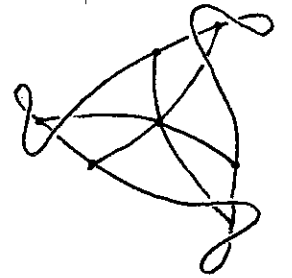

i STADE Y'iNDORERWAMU

Kugirango ufate ibitagangurirwa byo mu mazi.

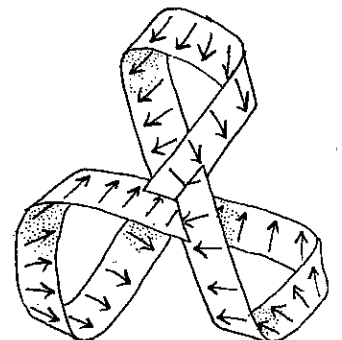
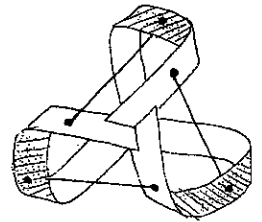
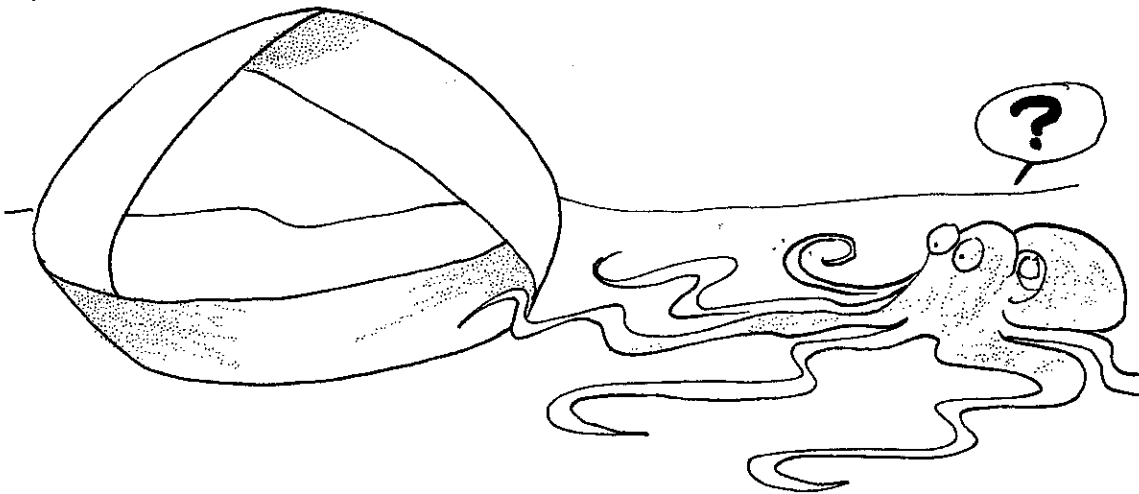

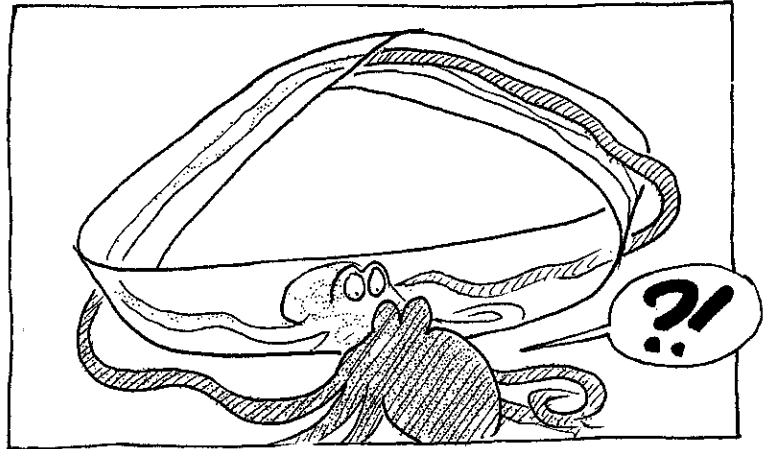
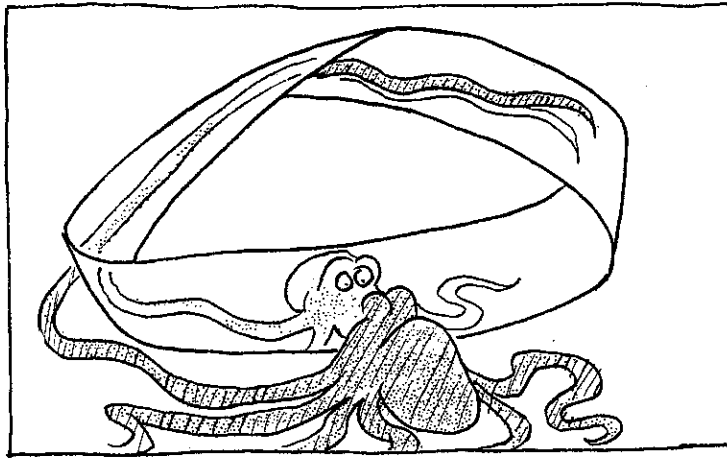

Habaye iki !?! igitagangurirwa cyo mu mazi kirasa n'igifite ubwoba

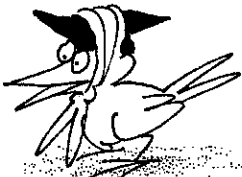

Arishima mu mutwe mu buryo bwo kwiheba.

Kandi NTACYO kizi kuko ukuboko kwacyo nyako kurashima ishusho y'umutwe wa cyo, naho ishusho y'ukuboko kwa cyo irashima umutwe wa cyo neza !

Igikoko cy'igipfayongo..

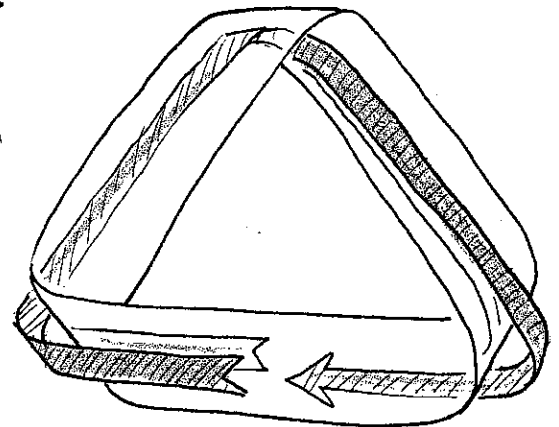

Nk'uko indorerwamu ifite uruhande rumwe, iyo ukoze umuzenguruko, ukuboko kwe kugaragara « mu rundi ruhande »

Kandi nk'uko indorerwamu ibonerana rwose hagati na hagati, ntabwo ari igicucu kuburyo atabibona !!!

Bigaragara nk'aho byamuteye ubwoba mu buryo butangaje!

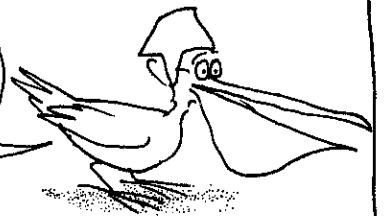

Ishyire mu mwanya we !



Urareba, nihaba umunsi uzishima ugutwi imbere y'indorerwamu kandi ntugire ikintu wumva, uzamenyeko ubwo iyo ndoredwamu imiterere yayo ari iy'uruhande rumwe.

Iyaba twashoboraga guhindura inyabuso ya BOYI mu ndorerwamu itagira irangi-ntangira, iniveri yaba idashobora gutandukanywa n'ishusho ya yo.



Ariko se ibyo nti byazaba bishobora kuzagira ingaruka mbi ? simbizi... ese ubwo, iniveri yinjijwe mu by'ukuri mu kwivuguruza, ntiyaba iriho yishora mu nzira yo kuyonga burundu ? (*)

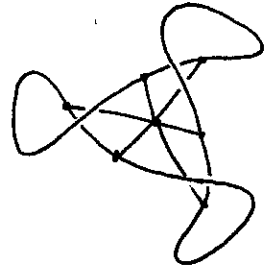
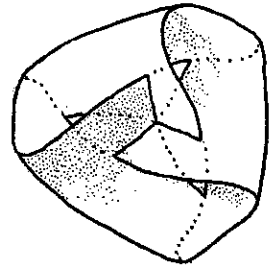
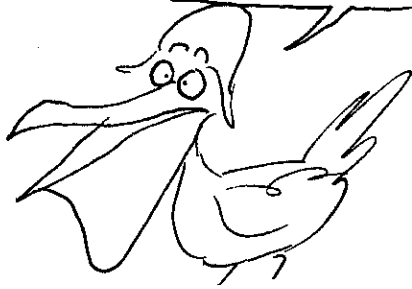

ESIPASE-GIHE YASAZE

Umuntu ashobora kwiga topoloji ya esipase-gihe akoresheje modeli za dimansiyo ebyiri, imwe ya esipase n'indi y'igihe.

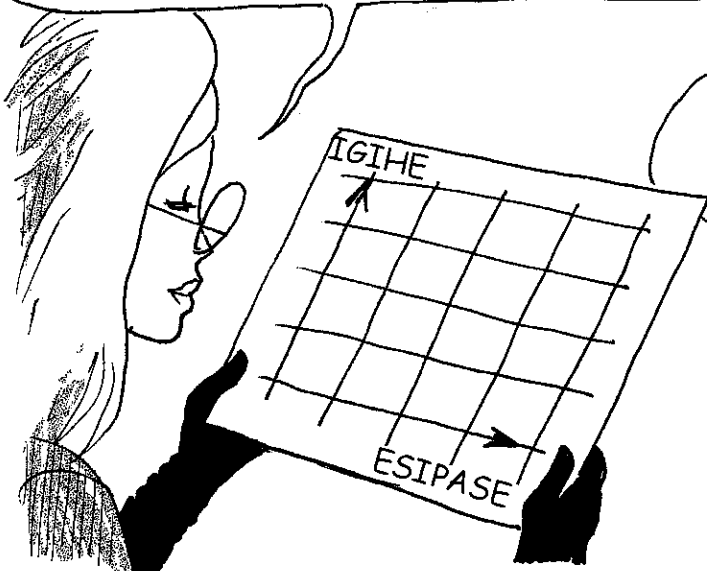

Byiboshye

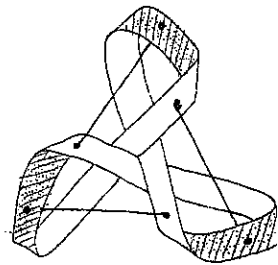

IKORWA RY'AKADOMO NYABUTATU

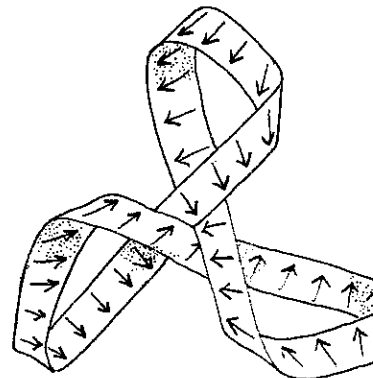

(*) IGERAGEZWA NTIRYIGEZE RIKORWA

Twabonye muri **BIGI BANGE** ko modeli ya iniveri **NGARUKANYA** ya **FIRIDIMANI** yashoboraga kwerekanwa n'ishusho iteye nk'ishapule igizwe n'isosiso zikurikiranye mu ruhererekane rudashira kandi ariko buri gace karemye nka **BIGI BANGE** nshya.

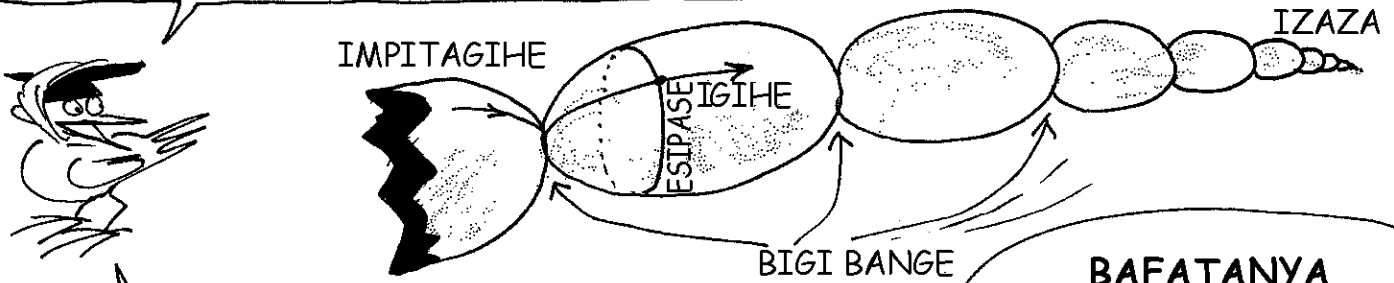

Buri **BIGI BANGE** iba iteye nk' ikinyamwihariko cyo mu bwoko bwa **POLE**.

BAFATANYA bate ibyo binyamwihariko ?

BIGI BANGE



Ufata umutemeru ukawutera ipasi.

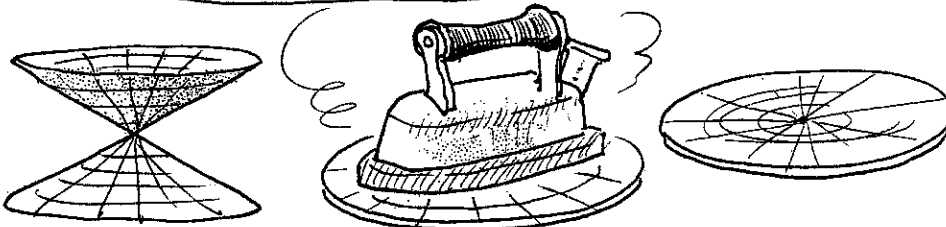

Dushobora kandi gutekereza ko ibiza bisa bishobora kugaruka bikaba mu buryo buhoraho budashira, muri icyo gihe twaba dufite ibi...

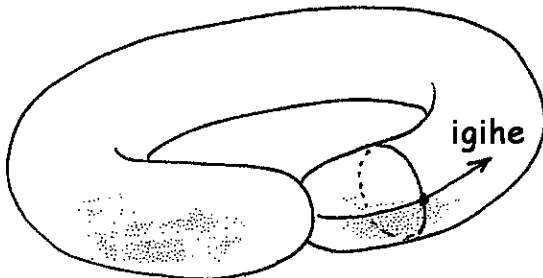

Cyangwa dushobora kuvuga duti **IGIHE** kigira **ITANGIRIRO** n'**IHEREZO**, nk'uku

BIGI BANGE

TURI HANO

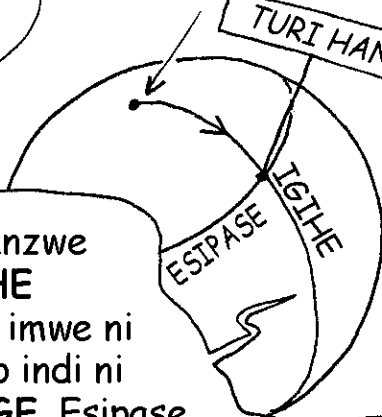

Muri iyo modeli isanzwe ya **ESIPASE-GIHE NYASIFERI**, pole imwe ni **BIGI BANGE** naho indi ni **ANTI BIGI BANGE**. Esipase ikagereranywa n'imizingi paralele, ekwateri nayo ikagaragaza ibihe by'izima rya cyane ntarengwa. « imirongo y'igihe » ikagaragazwa na za meridiye.



igihe



Kugirango umuntu ananare izo meridiye z'igihe, iyo **MILONGO YA INIVERI**, ntacyaruta **IKORNOGARAFE** nziza.

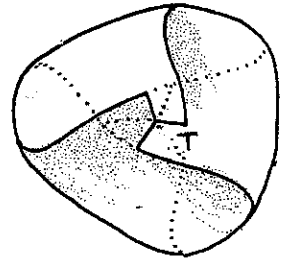
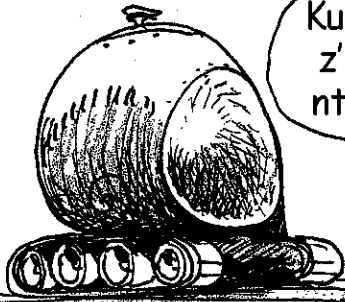

IKORWA
RYAKADOMO
NYABUTATU

Dushobora kujyana n'imwe muri ziriya mashine. Ibyo ntibyambabaza byo kujya kureba iyo esipase-gihe.

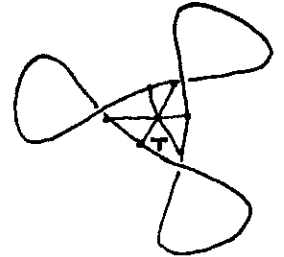

Ese Lewo na Tireziase bagiye he?

Hamwe na Tireziyasi, twakoze agatendo gahebuje!

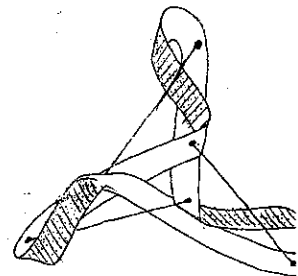

Twafashe utudomo twose tw'iyi esipase-gihe tuduhuza na ndwanyapodale dukoresheje imigozi...

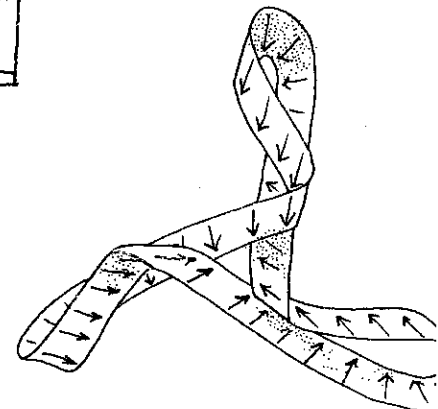
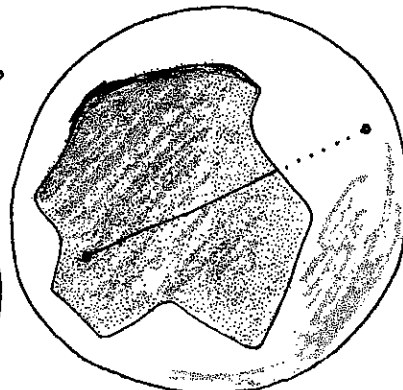

... hanyuma twinitse iyo migozi yose muri RETERESISOLE. Tereziasi yavuze ko ibyo bishobora gukora igeragezwa ryiza cyane ku birebana na esipase-gihe.

Mwebwe babiri, mwaracanganikiwe bihagiye. Ntimupima ingaruka za byo !!!

None se hazaba iki ?

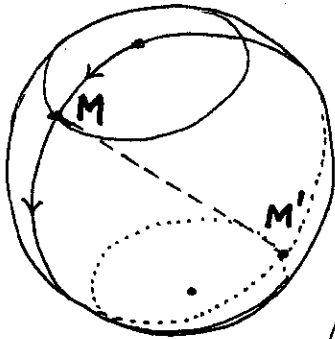

Bitewe n'iriya nyamaswa ya Tireziasiyasi, **ESIPASE-GIHE** iriho iriyegeranya. **IBIZA** byose bijyana n'interuro **Y'IKWEDUKA**, ni ukuvuga gutangirira kuri **BIGI BANGE** kugeza mu gihe ry'**IRAMBUKA** ry'**UMURENGERA**, bizisanga mw'**IHWANIRO** n'ibiza bijyanye n'interuro y'**IYEGERANYA** binyujijwe mw'ihuza ry'**INTARA RWANYAPODALE**.

BIGI BANGE na **NDWANYABIGI BANGE** bizisanga byahwanye, si byo ?

Ko bisekeje, ko bitangaje, mbega ihuza !

Ndakyeka ko ibyo byigeze kuba bigamijwe ? (*)

Iyo ntaza gutega amatwi na rimwe Tireziasiyasi.



Ariko iyo fenomene y'ihwaniro izakora kuburyo intara za esipase-gihe, ziteganye na ndwanyapode za zo zizisanga mw'IHANGANA MU BIHE n'izo ndwanyapode.

Ntibishoboka !

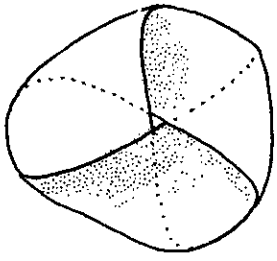

Habe na gato ! urugero, fata intara iri mu nkyengero za eqwateri y'iyi esipase-gihe nyasiferi ihwanye n'ibihe by'irambuka ntarengwa. Muyibona neza cyane yiyegyeranya kuri yo yonyine muri filime D

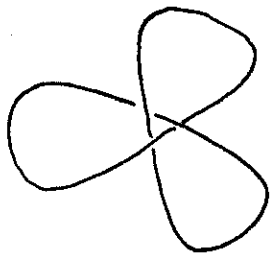

IMYAMBI Y'IGIHE yishyira mw'IHANGANA.

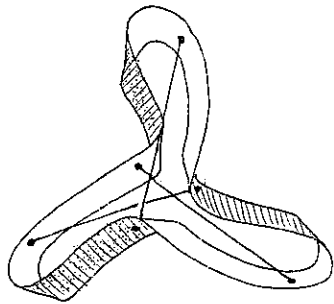
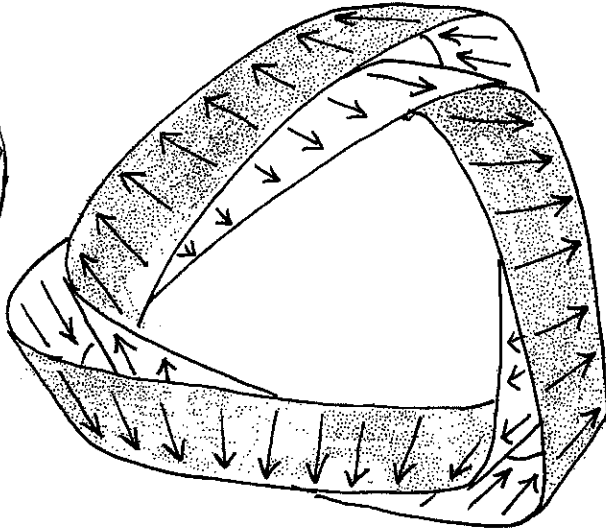
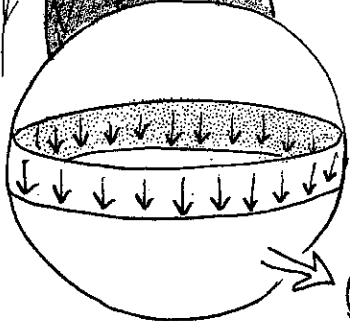

Urashaka kuvuga ko icyari kuba **IMPITAGIHE** kuri bamwe cyakwitwa **IBIHE BIZAZA** ku **BARI KU NDWANYAPODALE** za bo ?

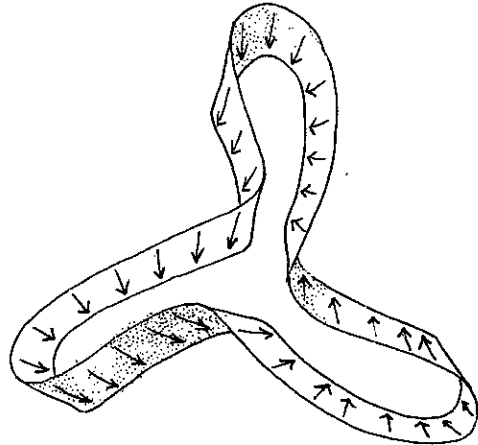

Nshuti yanjye Lewo,
mwakoze akazi keza

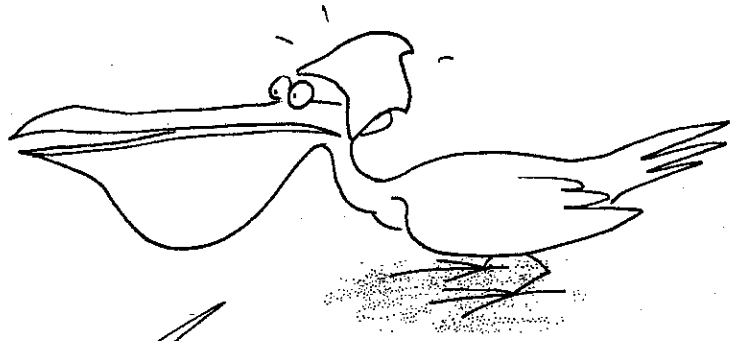
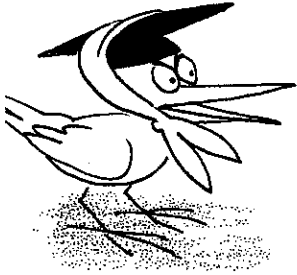

Murashaka kuvuga yuko ibi bishobora gushyira
iniveri mu kwivuguruza ndashyigikirwa ?

Ubwoko bw'amayobera nyakuri

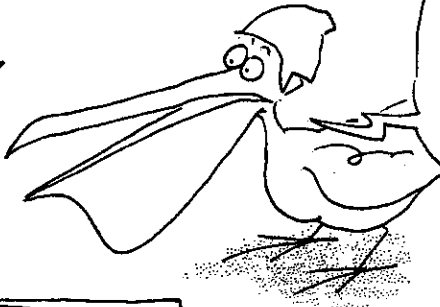
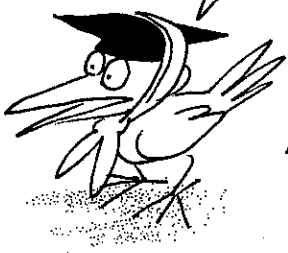

Igihe **UBUGENI BWA
RETERESISOLE** buzaba bwa koze,
Iniveri izashobora kwireba iturutse
kure inyuma ya yo kandi tuzabona
igihe gisubira inyuma n'ingoga.

Mu bigaragara,
Tireziyasi yaciye he ?



Reka twizamukire muri koronosikafe.
Dushobora kugerageza tukamuhamagara.

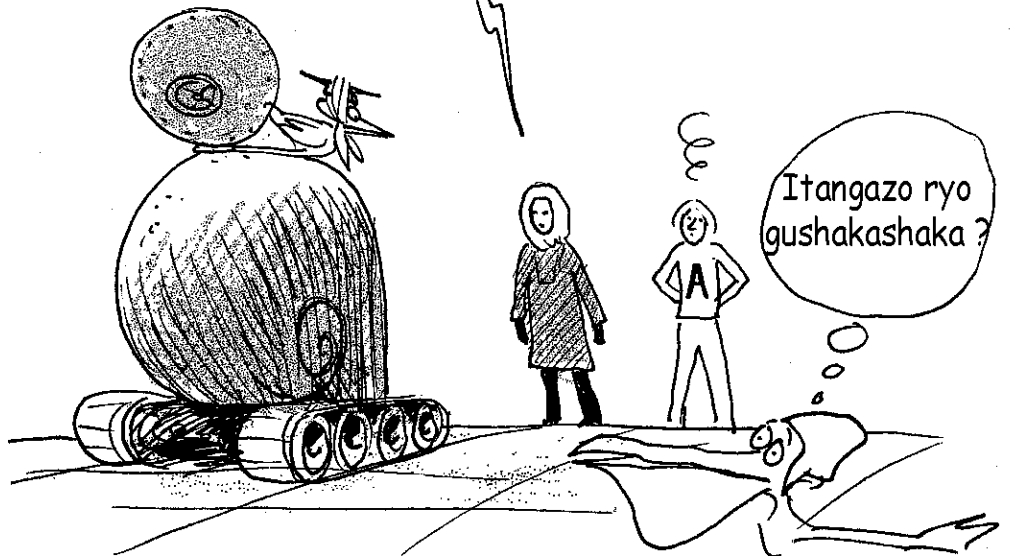



Alo, Tireziyasi, uranyumva ?

Buretse, niba Tireziyasi ari, kuri twebwe, **RETOROKORONE** kandi se noneho dushoboye kuvugana na we, azaba icyaricyo cyose tuzamubwira.

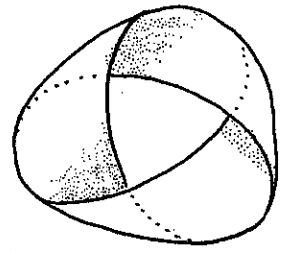

Bibi nyuma y'ibindi byose, mu by'ukuri, ubwo butumwa, mu **GIHE CYA BWO NYACYO** ni we uzabwitangira !!

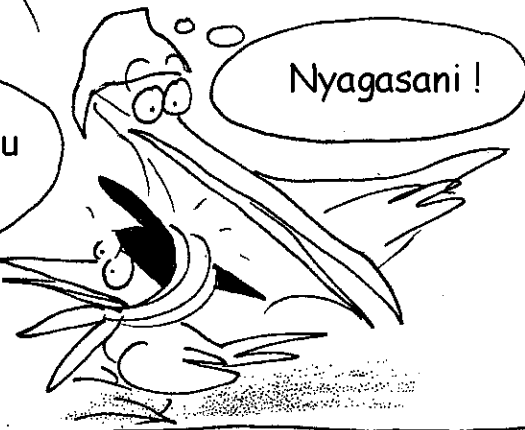

Nyagasani !

Kandi ibyaribyo byose, niduhura, bizaba bibi kurusha !

Feyinimani yatekerezaga ko indwanyamatsiyeri yafataga igihe ihereye inyuma !

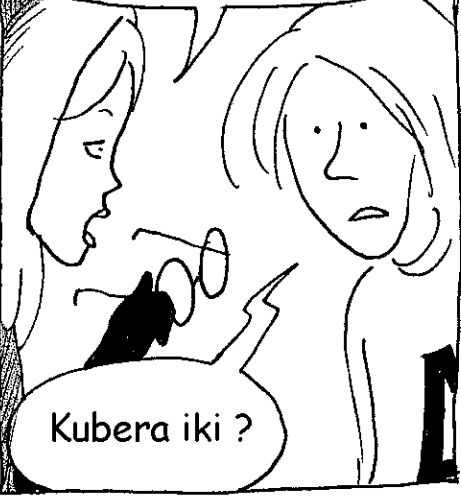
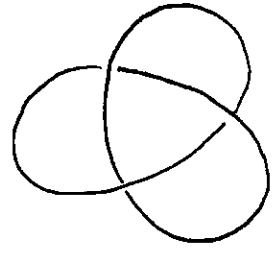

Kubera iki ?



Naho padiri **LEMETERE (*)** yatekerezaga ko indwanyamatsiyeri yari matsiyeri irebwe uhereye inyuma (*)

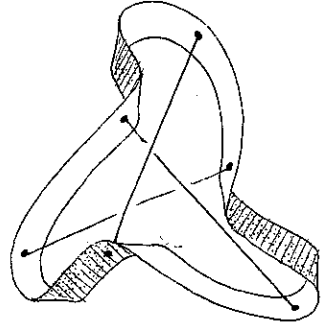

Noneho, ku byago duhuye na Tireziyasi, yaba yarabaye **INDWANYA-TIREZIYASI**



Bite se, **BUMU?**

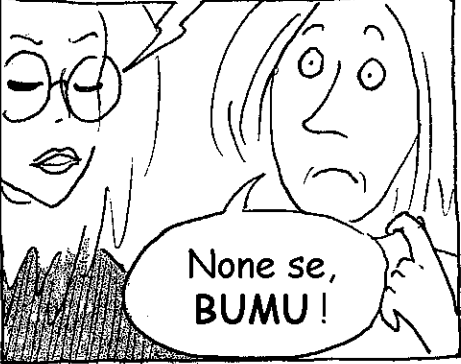

None se, **BUMU!**

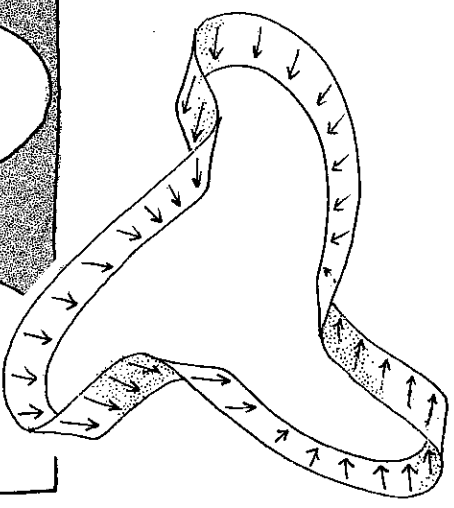

(*) Reba **BIGI BANGE** (Icapiro **BELINE**)

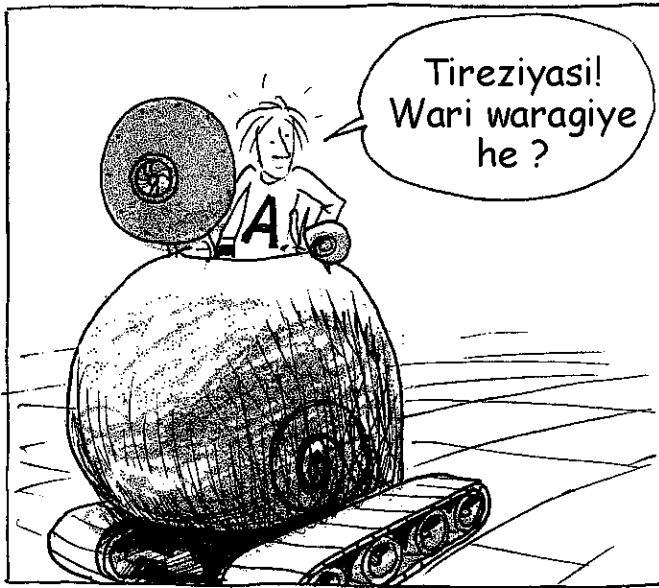

Tireziyasi!
Wari waragiye
he ?



KOLONKE !

Nari
naragiye
kunanura
amaguru.



Hee, KORONOSIKAFE !
Yatangiye kugenda...

Iyo mutaba mwakubise
urugi cyane nk'uko, nk'uko !

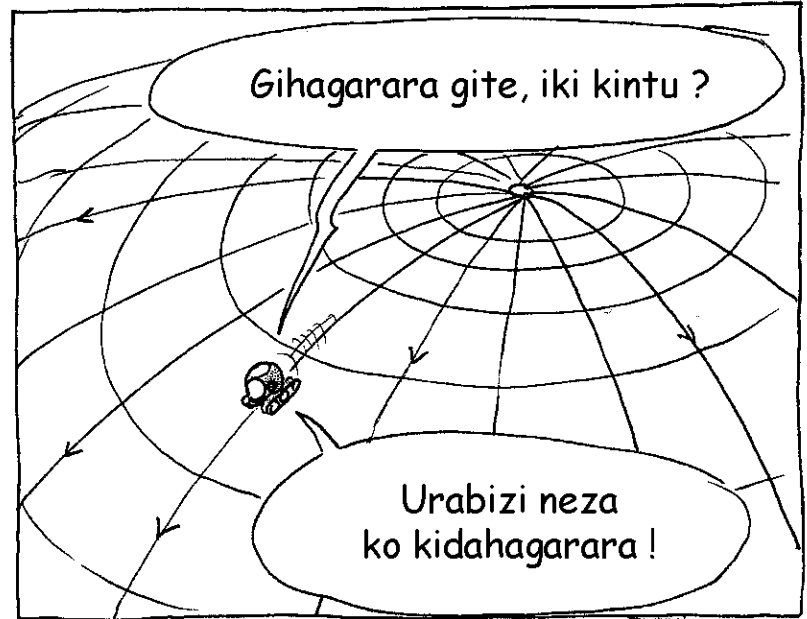

Gihagarara gite, iki kintu ?

Urabizi neza
ko kidahagarara !



None se iyoborwa ite ?

Wowe n'ibitekerezo
bya we !!

Aha !

Ntawuyobora KORONOSIKAFE.
Ni yo ibayobora. Kandi ikurikira **UMURONGO
WA INIVERI**, ni ibyo, nta kindi...

Hee ! Reba ibiri imbere ya we neza !

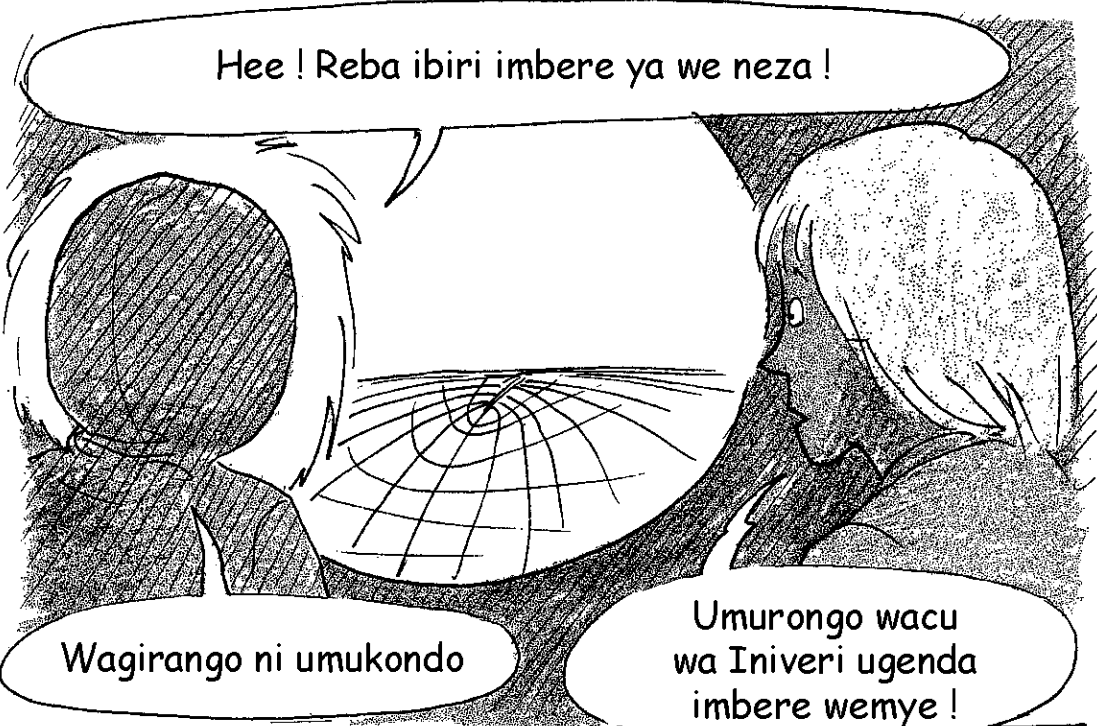

Wagirango ni umukondo

Umurongo wacu
wa Iniveri ugenda
imbere wemye !

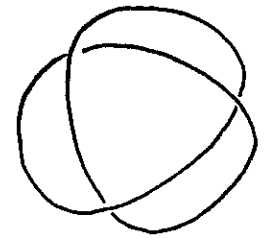
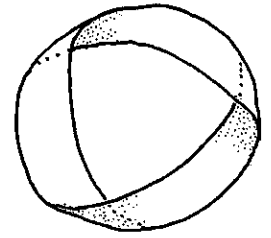

Mbona isa n'ICYOBO CY'UMUKARA !

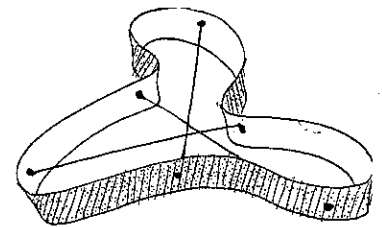
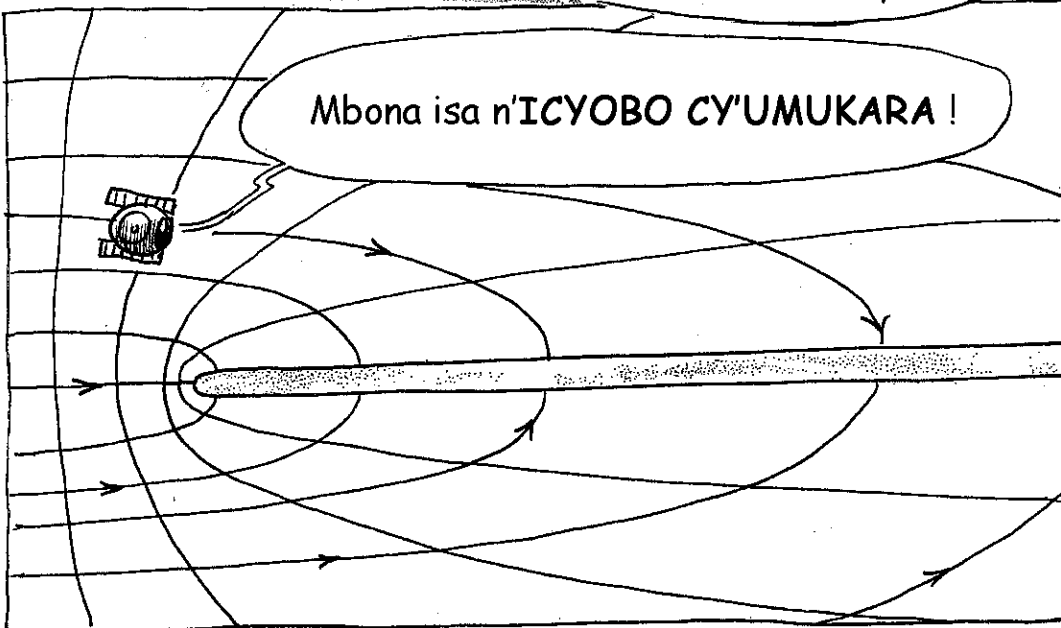

Ni ikinyamwihariko
cy'uruhe rwego?

Aha, ni igihe
kiza cyo kwibaza
ikibazo nk'icyo !

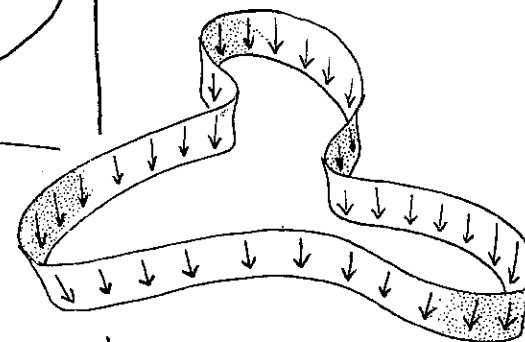

Bijya gusa n'ubwoko bw'intereko y'ibipesu kuri esipase-gihe.

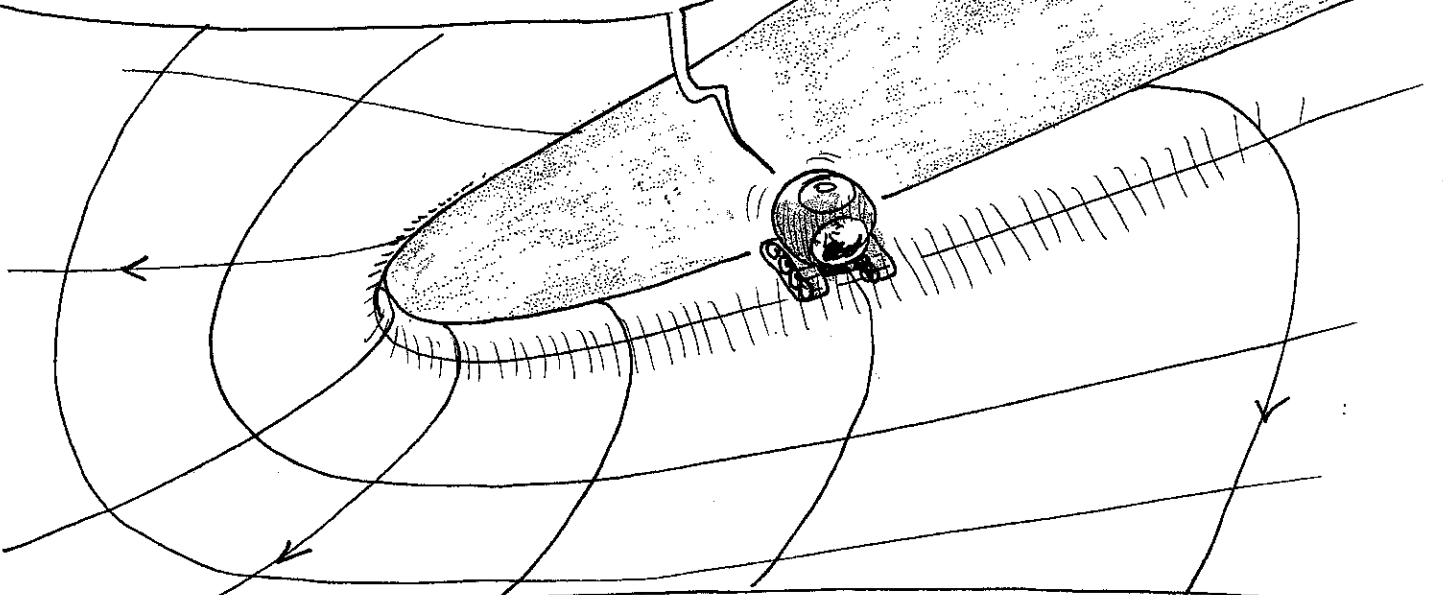

Imirongo ya iniveri ubu IRASOHOKA iturutse mu kinyamwihariko, hano hasi

Ndemera ko ubu dutunguka nk'IRIBA RYERA

Dore turi ku rundi ruhande rwa iniveri.

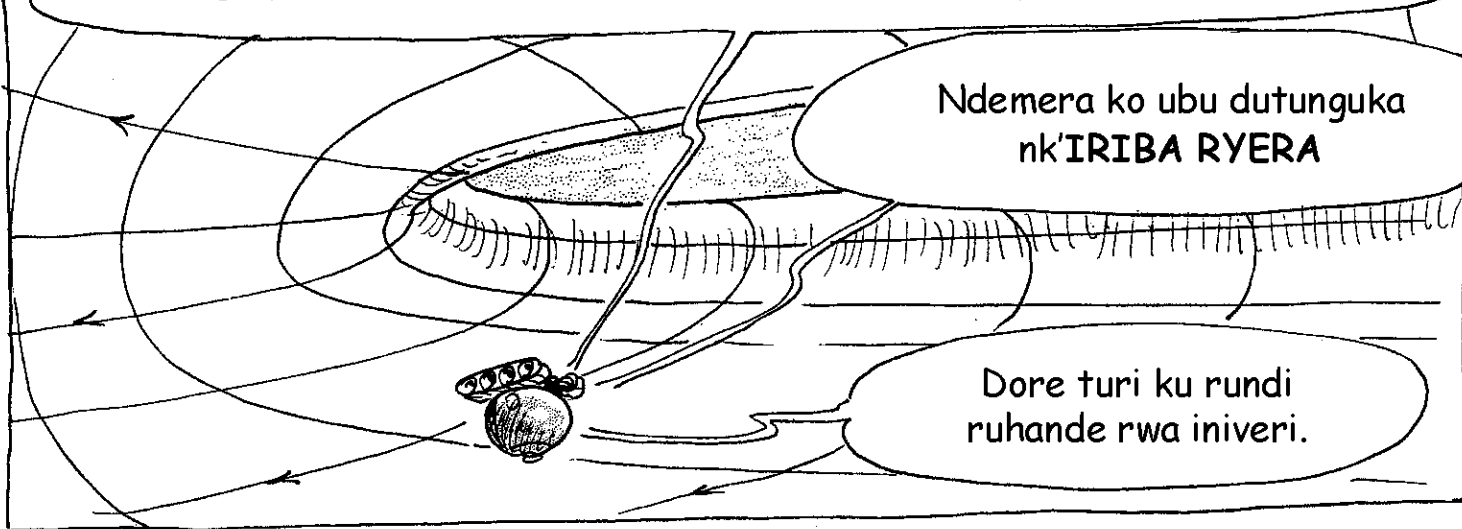

Birasa, mu buryo butangaje, nk'ibyari ku rundi ruhande, uretse ko turiho dukurikira izira icuritse. Kandi jye ndabona ibyo mbona nsa n'uwabibonye mbere, mwebwe se si uko?

Ariko, byashobotse,
nabigeze ho!
INDORERWAMU !...

Indorerwamu
iteye ite ?

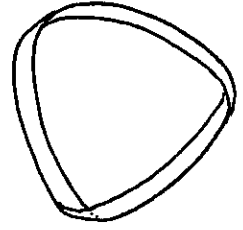
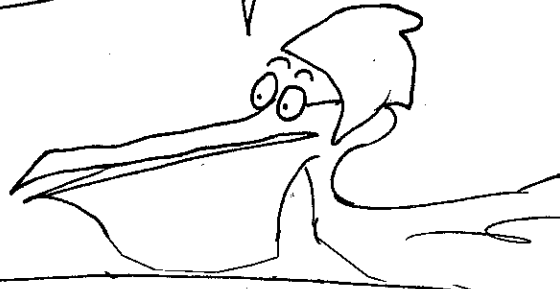

Ibi bice bibiri bya Iniveri birasa
n'ibiteganye mu ndorerwamu. Ariko ni **INDORERWAMU
NYASIPESI-GIHE**. Ku rundi ruhande rw'umwobo
w'umukara, byose biracuritse ugereraniye n'igihe.
Amahame ya fisikye arasa nayo nka curitse :
ikinyamwihariko kirasunika matsiyeri aho kuyikurura !! (*)

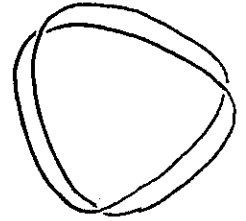

Noneho rero ibyo biravuga
ko tugiye gusubira kubaho
dukurikije inzira icuritse yi
by'aka gatabo k'amashusho.



Hee yego. **KORONOSIKAFE**
igiye kwihagarika, noneho Anselimi
azakingura umuryango hanyuma
Tirezziyasi aje kuba atembera.
Hanyuma rero...

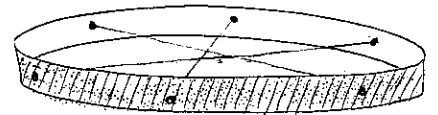

UMUYOBORO W'IMPANDE
EBYIRI UTUDOMO
NDWANYAPODALE DUFATANYE

UMUSOZO

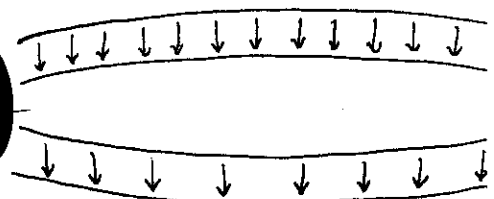

(*) IMITERERE IMWE ISHOBOA KUBAHO MURI DIMANSIYO YA 4.

UMWIHARIKO W'UBUMENYI

BOYI, umunyeshuri wa Hiberi,, yavumbuye iyo nyabuso imwitirirwa mu 1902. Iyerekanwa ryizwe neza rya mbere rya yo ryakozwe mu 1981 na Jerome SURIYO (umuhungu w'umuhanga mu mibare J.M. SURIYO) afataniye n'uyu mwanditsi. Uburyo bakoresheje ni ubwa gikorikori butiranya meridiye y'iyonyabuso na za elibuse zihita zipimwa. Akadomo kajyendajyenda gatangwa na :

$$\begin{cases} x = X_1 \cos \mu - Z_1 \sin \alpha \sin \mu \\ y = X_1 \sin \mu + Z_1 \sin \alpha \cos \mu \\ z = Z_1 \cos \alpha \end{cases} \text{ Ukoresheje: } \begin{cases} X_1 = \frac{A^2 - B^2}{\sqrt{A^2 + B^2}} + A \cos \theta - B \sin \theta \\ Z_1 = \sqrt{A^2 + B^2} + A \cos \theta + B \sin \theta \end{cases}$$

$$\alpha = \frac{\pi}{8} \sin 3\mu \begin{cases} A(\mu) = 10 + 1,41 \sin(6\mu - \pi/3) + 1,98 \sin(3\mu - \pi/6) \\ B(\mu) = 10 + 1,41 \sin(6\mu - \pi/3) - 1,98 \sin(3\mu - \pi/6) \end{cases}$$

Meridiye : umuzingi μ = ikidahinduka ; θ ifata igipimo kuva kuri 0 kugeza kuri 2π , μ ifata igipimo kuva kuri 0 kugeza kuri π .

Porogaramu yo muri BAZIKE ikurikira itanga inzira yakurikijwe ku mpapuro za mbere zibanze:

```
1  REM TRACE MERIDIENS DE LA SURFACE DE BOY
3  HOME : TEXT
50  PI = 3,141592:P3 = PI / 3:P6 = PI / 8:P8 = PI / 8
60  HGR : HCOLOR= 3
90  FOR MU = 0 TO PI STEP 0.1
95  P = P + 1
100 D = 34 + 4.794 * SIN (6 * MU - P3)
110 E = 6.732 * SIN (3 * MU - P6)
120 A = D + E:B = D - E
130 SA = SIN (P8 * SIN (3 * MU))
140 C2 = SQRT (A * A + B * B):C3 = (4 * D * E) / C2
160 CM = COS (MU):SM = SIN (MU)
180 FOR TE = 0 TO 6.288 STEP .06
190 TC = A * COS (TE):TS = B * SIN (TE)
200 X1 = C3 + TC - TS
210 Z1 = C2 + TC + TS
250 REM VOICI LES 3 COORDONNEES
300 X = X1 * CM - Z1 * SA * SM
310 Y = X1 * SM + Z1 * SA * CM
350 REM PROGRAMME DE DESSIN
360 HPLOT 130 + X,80 + Y
400 NEXT TE: NEXT MU
```



